



12843 Foothill Blvd.,  
Suite D  
Sylmar, CA 91342  
818 898 3380 voice  
818 898 3360 fax  
[www.dnfcontrols.com](http://www.dnfcontrols.com)

# **Model No. 2034CL-L-PBIO (&2034CL-L-T)**

## **300 CLIP INSTANT ACCESS SYSTEM**

*Louth Protocol*

**VERSION 3.0 SOFTWARE**

**Note: Supports up to 3 Video Server Channels**

# **User Manual**

# Table of Contents

<b>1.</b>	<b>REVISION HISTORY</b>	<b>4</b>
<b><u>GETTING STARTED...</u></b>		<b><u>5</u></b>
<b>2.</b>	<b>SYSTEM DESCRIPTION</b>	<b>5</b>
	DEFINITIONS	5
<b>3.</b>	<b>SYSTEM INSTALLATION</b>	<b>6</b>
	A. SHOTBOX	6
	B. ST300 CONTROLLER	6
	C. PRODUCTION SWITCHER	7
<b>4.</b>	<b>VIDEO SERVER SETUP</b>	<b>9</b>
<b>5.</b>	<b>LOAD A CLIP</b>	<b>9</b>
<b>6.</b>	<b>LEARN A CLIP OR CLIP COMBINATION</b>	<b>10</b>
	A. LEARN ON THE SHOTBOX	10
	B. LEARN ON THE PRODUCTION SWITCHER	10
	C. LEARN ON THE ST300	10
<b>7.</b>	<b>RECALL</b>	<b>11</b>
	A. RECALL ON THE SHOTBOX	11
	B. RECALL ON THE PRODUCTION SWITCHER	11
	C. RECALL ON THE ST300	11
<b>8.</b>	<b>SHOTBOX SHOTKEY MAPPING TO SHOTLIST LOCATIONS</b>	<b>11</b>
<b>9.</b>	<b>PBIO REGISTER MAPPING TO SHOTLIST LOCATION</b>	<b>12</b>
<b>10.</b>	<b>TRIGGER</b>	<b>12</b>
<b><u>ADVANCED...</u></b>		<b><u>13</u></b>
<b>11.</b>	<b>CREATE A CLIP</b>	<b>13</b>
	A. SET THE RECORD DURATION	13
	B. CREATE A NEW NAME	13
	C. RECORD A CLIP	14
<b>12.</b>	<b>CREATING SUBCLIPS</b>	<b>15</b>
	A. MARK IN (OUT) POINT	15
	B. DELETE IN (OUT) POINT	15
	C. MANUALLY ENTER IN (OUT) POINT	15
	D. CREATE SUBCLIP	15
<b>13.</b>	<b>RECUE THE CURRENTLY LOADED CLIP</b>	<b>16</b>
<b>14.</b>	<b>VIEW THE CLIP ID OF THE CURRENTLY LOADED CLIP</b>	<b>16</b>
<b>15.</b>	<b>VIEW CONTENT OF CUE POINTS ON THE SHOTBOX</b>	<b>17</b>
<b>16.</b>	<b>SHOTBOX CONTROL SWITCHES</b>	<b>17</b>
<b>17.</b>	<b>CLEAR SINGLE CUEPOINT</b>	<b>17</b>
<b>18.</b>	<b>TRANSFERRING CUELISTS</b>	<b>18</b>
	A. TO TRANSMIT CUE POINTS TO THE ST300	18
	B. TO TRANSMIT CUE POINTS TO THE PC	18
<b>19.</b>	<b>RECEIVE CUELIST FUNCTION.</b>	<b>19</b>
	A. TO RECEIVE CUE POINTS FROM THE ST300	19
	B. TO RECEIVE CUE POINTS FROM THE PC	19

<b><i>REFERENCE . . .</i></b>		<b>20</b>
<b>20.</b>	<b>SETUP MENU</b>	<b>20</b>
<b>21.</b>	<b>FUNCTION TABLE</b>	<b>23</b>
<b>22.</b>	<b>SPECIFICATIONS</b>	<b>24</b>
	ST300	24
	RS422 SERIAL CONNECTOR	24
	AUX PORT RS422 SERIAL CONNECTOR	24
	GPI IN/OUT CONNECTOR	25
	ST420 (SHOTBOX)	25
	RS422 SERIAL CONNECTOR	25
	POWER CONNECTOR	25
<b>23.</b>	<b>TROUBLESHOOTING</b>	<b>26</b>
	A. ST420 TROUBLESHOOTING	26
	B. VERSION 3.0 HARDWARE OF ST300 ONLY	26
<b>24.</b>	<b>KEY LAYOUT</b>	<b>27</b>
<b>25.</b>	<b>DNF CONTROLS LIMITED WARRANTY</b>	<b>28</b>

Manual Version..... 1.5 020504  
Document ID..... 2034CL-L-PBIO User Manual

# 1. REVISION HISTORY

070103	Rev. 1.1	Added Section CLEAR SINGLE CUEPOINT, and Key Layout. Added the following to SETUP MENU. CLIP SOM RECALL MODE VIDEO STANDARD
110303	Rev. 1.2	Added DNF Controls Limited Warranty. Updated Receive Cue List & Transmit Cue List Function description.
120903	Rev. 1.3	Added CREATING SUBCLIPS section.
012204	Rev. 1.4	Changed Key Layout.
020504	Rev. 1.5	Added note to cover and System Description: Supports up to 3 Video Server Channels.

# *Getting Started . . .*

## **2. SYSTEM DESCRIPTION**

- \* NOW, production switchers can load & play video clips on Grass Valley Group PROFILE and other video servers.
- \* Use the EMEM or SNAPSHOT Learn & Recall functions of the production switcher to load and play a video clip from a Recall or timeline.
- \* Use the Run and Trigger functions of the production switcher to Play, Stop or Recue the video clip. Instantly load a video clip at the press of a button.
- \* Instantly load a FILL clip & KEY clip at the press of ONE button, then play out both channels in sync.

The 300 Clip Instant Access System consists of the ST300-SSM VTR Controller, STS420 Shotbox and Shotlist Software.

The ST300 controls up to 3 video channels individually or ganged.

SHOTLIST provides fast access to existing video clips stored on Grass Valley Group's PROFILE, other DDR, VDR or Video Server supporting Louth Protocol.

The SHOTLIST contains up to 300 CLIP IDs, stored in non-volatile memory in the ST300.

Any clip in the SHOTLIST can be quickly loaded by simply entering the associated 3-digit number of its location, then pressing [**LOAD**]. Press [**PLAY**] to play the clip.

Press [**RECUE**] to recue to the beginning of the clip or to the "recalled" time if defined.

Upon receipt of the Learn command, the ST300 saves the CLIP IDs of the currently loaded clips, the current time of each clip, the VTRs they are loaded on and the current GANG mode into the appropriate Cue Point.

When the RECALL command is received, the ST300 loads the learned Clips onto the learned VTRs, cues the Clips to the learned time and restores the learned GANG mode.

Learn & Recall may also be done directly from the ST300.

## **DEFINITIONS**

Throughout this manual, VTR, DDR, VDR & Video Server will be referred to collectively as "Video Server."

The ST300-S/SM is referred to as the ST300.

The ST420 SHOTBOX is referred to as "SHOTBOX."

SHOTKEY refers to the 1-30 switches on the SHOTBOX.

Words surrounded by brackets, for example, [**ENTER**], are keys on the ST300 or the SHOTBOX. [**XXX**] + [**XXX**] means hold the two keys down simultaneously.

### 3. SYSTEM INSTALLATION

#### a. SHOTBOX

- 1) Plug one end of a standard 9-pin, RS422 serial cable into the OUTPUT connector on the rear of the SHOTBOX. Plug the other end of the cable into the AUX connector on the rear of the ST300.
- 2) Connect the 5 VDC, 1Amp POWER SUPPLY into the POWER connector on the rear of the SHOTBOX. Plug the POWER SUPPLY into an outlet, 90 VAC to 240 VAC.

#### b. ST300 CONTROLLER

- 1) Plug one end of a 9-conductor, RS422 serial cable into the VTR 1 (2, 3 or 4) connector on the rear of the ST300. Plug the other end of the cable into the 9-pin REMOTE connector on the Video Server.
- 2) Connect the +5, +12, -12 VDC POWER SUPPLY into the POWER connector on the rear of the ST300. Plug the Power Supply into an outlet, 90 VAC to 240 VAC.
- 3) Assign logical Louth ports to ST300's VTR connectors.
  - a) Press **[MENU]**.
  - b) Turn the Wheel until VTR Louth Address is displayed.
  - c) Press VTR[1], VTR[2], or VTR[3] to select VTR.
  - d) Assign a Louth Port address for that VTR 0-9. (0 turns that channel **OFF**.)
  - e) The second line of the display will show "Input=Enter, Out=ESC"
  - f) Press **[ENTER]** to select an Input Port.  
(A "-" will appear in front of the selected number.)  
**OR**  
**[ESC]** to select an Out Port.
  - g) Repeat steps c-f to assign a Louth Address to ALL VTRs you want to use.
  - h) Press **[ESC]** to leave the MENU mode.
- 4) Check the other options in the SETUP MENU prior to using the ST300 to confirm proper Record mode and other User settable modes.

## c. PRODUCTION SWITCHER

- 1) Connect a standard cable (RS422, 9-pin serial cable) to the supplied turnaround adapter. Plug the turnaround adapter into the “VTR4” connector on the rear of the ST300. Connect the other end of the cable to the Peripheral Bus Connector on the production switcher. (Communication Format- 38.4K, 8,1)
- 2) To select a Production Switcher type (Default = Grass Valley Group).
  - a) Press [MENU] and turn the Wheel until “SWITCHER” is displayed.
  - b) Press Softkeys to toggle between Sony and Grass Valley.
  - c) Press [ESC] at anytime to exit MENU mode.
- 3) The ST300 has 4 Peripheral Device Addresses, one for each VTR that it controls.

To set the Device Address for each VTR:

- a) Press [MENU] and turn the wheel until “Peripheral Address” is displayed.
  - b) Press VTR[1], VTR[2], VTR[3] or VTR[4] to select a VTR.
  - c) Assign a Peripheral Device Address for that VTR, from 0 to 23, by entering the desired address using the numeric keypad.  
**OR**  
Press [DEL] to turn off the device.
  - d) Select the next VTR and assign a Peripheral Device Address for it.
  - e) When done, press [ESC] to exit MENU mode.
- 4) Select Parity:
    - a) Press [MENU] and turn the Wheel until “Parity” is displayed.
    - b) Press Softkey to select ODD, EVEN or NONE parity to match the settings on the Production Switcher.
    - c) Press [ESC] to exit menu mode.
  - 5) Configure the production switcher:

On the production switcher –

- Enable the Peripheral Bus.
- Enable the Peripheral Device Addresses assigned to the ST300.
- Enable the appropriate Learn/Recall levels.
- Enable the Timeline or Recall Trigger function.

## CONNECTION DIAGRAM

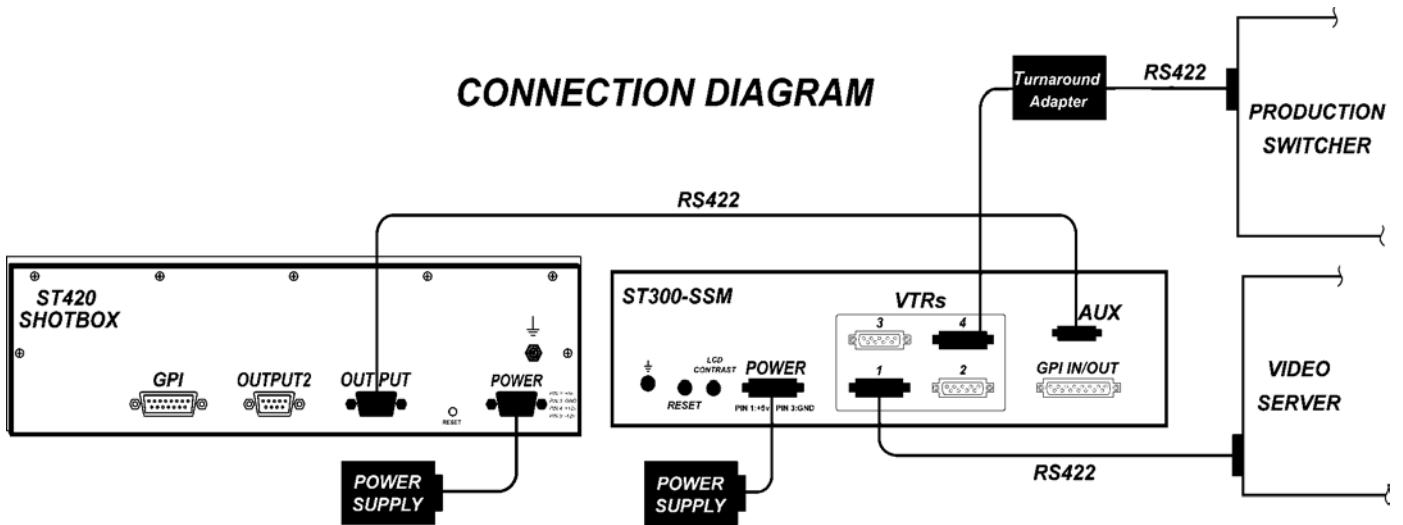

Installation is complete.

## 4. VIDEO SERVER SETUP

Select LOUTH Broadcast communications protocol on the VIDEO SERVER to be controlled.

If required, assign a serial port on the VIDEO SERVER through which the ST300 will control it.

**NOTE:** In LOUTH mode, the VIDEO SERVER **ONLY** allows Full Record. (INSERT and ASSEMBLE record modes are disabled.)

Setup is complete.

## 5. LOAD A CLIP

- a. Select a VTR by pressing VTR[1], VTR[2], or VTR[3].
- b. Press [CLIP LIST] to view the list of CLIP IDs that are resident on the Video Server. The CLIP LIST indicator will turn on.
- c. Press [LOAD] to create and load a new clip. (Creating a clip is described in “CREATE A CLIP,” Section 11.)

**OR**

Turn the Wheel to view the existing CLIP IDs on the video server.

Turn the Wheel clockwise to scroll forward, or counter-clockwise to scroll backward, through the list of available CLIPs. Backward scrolling is limited to the last 10 CLIP IDs viewed.

**OR**

Manually enter a clip ID using the ST300 numeric keypad, or Shotbox Qwerty keyboard.

- d. Press [LOAD] to load the selected CLIP ID for playout.
- e. Locate the clip to the desired IN time.
- f. Repeat steps a-e until clips are loaded into the desired VTRs.
- g. Set the GANG mode, if required.

## 6. LEARN A CLIP OR CLIP COMBINATION

### a. LEARN ON THE SHOTBOX

- 1) Press [**LEARN**] on the ST420. The LEARN indicator will turn on.
- 2) Select the desired BANK and ShotKey.
- 3) The Learned CLIP ID will be displayed on the pressed key.  
**NOTE:** This will overwrite what you have assigned to the key previously.
- 4) The ST300 will remember the loaded clip(s), current time and gang configuration of the active VTR(s).
- 5) Press [**LEARN**] to exit at any time.  
**NOTE:** The [**LEARN**] key toggles LEARN mode on/off.

### b. LEARN ON THE PRODUCTION SWITCHER

- 1) On the ST300, load a clip(s) on the desired VTR(s). (See “**LOAD A CLIP**,” Section 5.)
- 2) Select and enable the Peripheral Device Addresses for the ST300.
- 3) Do a LEARN to the desired REGISTER.

The ST300 will save the VTR #, loaded CLIP ID and current IN time into the REGISTER number in the ST300.

### c. LEARN ON THE ST300

- 1) Select the desired Cue Point by pressing [**NEXT CUE**], [**LAST CUE**] or by manually entering the Cue Point using the numeric keypad.

The selected Cue Point number is shown on the bottom line of the display.

- 3) Press [**SHIFT**] + [**MARK**] to initiate the LEARN.  
The display will show:

Select VTR: LEARN-Lrn      ESC-Cancel
--

- 4) Press the VTR key desired, [**1**], [**2**], [**3**].
- 5) Press [**MARK**] and the ST300 will:  
LEARN (save) the VTR Number (1,2,3), loaded CLIP ID and current IN time to the selected Cue Point.

## 7. RECALL

### a. RECALL ON THE SHOTBOX

Select the desired Cue Point by pressing the BANK and ShotKey.

The ST300 will automatically load the Learned clips on the Learned VTRS, cue the clips to the Learned time, then set the Learned GANG mode.

### b. RECALL ON THE PRODUCTION SWITCHER

Recall the desired REGISTER NUMBER.

The ST300 will automatically load the Learned clips on the Learned VTRS, cue the clips to the Learned time, then set the Learned GANG mode.

### c. RECALL ON THE ST300

- 1) Select the desired Cue Point by pressing [NEXT CUE], [LAST CUE] or by manually entering the Cue Point using the numeric keypad.

The selected Cue Point number is shown on the bottom line of the display.

- 2) Press [LOAD] on the ST300.

The ST300 will automatically load the Learned clips on the Learned VTRS, cue the clips to the Learned time, then set the Learned GANG mode.

## 8. SHOTBOX SHOTKEY MAPPING TO SHOTLIST LOCATIONS

The SWITCHES on the SHOTBOX access the SHOTLIST locations as follows:

BANK 0, SWITCHES 1 → 30 access SHOTLIST locations 001 to 030.  
BANK 1, SWITCHES 1 → 30 access SHOTLIST locations 101 to 130.  
BANK 2, SWITCHES 1 → 30 access SHOTLIST locations 201 to 230.  
BANK 3, SWITCHES 1 → 30 access SHOTLIST locations 301 to 330.  
BANK 4, SWITCHES 1 → 50 access SHOTLIST locations 401 to 430.  
BANK 5, SWITCHES 1 → 30 access SHOTLIST locations 501 to 530.  
BANK 6, SWITCHES 1 → 30 access SHOTLIST locations 601 to 630.  
BANK 7, SWITCHES 1 → 30 access SHOTLIST locations 701 to 730.  
BANK 8, SWITCHES 1 → 30 access SHOTLIST locations 801 to 830.  
BANK 9, SWITCHES 1 → 30 access SHOTLIST locations 901 to 930.

## 9. PBIO REGISTER MAPPING TO SHOTLIST LOCATION

Register 0-30 →	Cue Point 0-30
Register 31-60 →	Cue Point 101-130
Register 61-90 →	Cue Point 201-230
Register 91-99 →	Cue Point 301-309

## 10. TRIGGER

The operator fires a trigger using the Timeline or Run function on the production switcher. The ST300 puts the Video Server into the following modes based on the trigger value:

### GRASS VALLEY GROUP

<u>Trigger Value</u>	<u>Mode</u>
0	Play
1	Recue to beginning of clip
2	Slo-mo using ST300 Preset Speed
3	Reverse Play
4	Still Frame
5	Play
6	Record
7 or greater	Play

### SONY

<u>Trigger Value</u>	<u>Mode</u>
0	Recue to beginning of clipPlay
1	Play
2	Slo-mo using ST300 Preset Speed
3	Reverse Play
4	Still Frame
5	Play
6	Record
7 or greater	Play

To control more than one VTR, enable the Peripheral Device Address for the required VTRs. The Trigger will be sent to the enabled devices.

**OR**

GANG the required VTRs on the ST300. See the Menu Table for GANG instructions. Enable the Peripheral Device Address for one of the GANGED VTRs. The Trigger will be sent to the enabled VTR. The other VTRs in the GANG will perform the same action.

## *Advanced . . .*

### **11. CREATE A CLIP**

**NOTE:** New clips can be created ONLY if the INPUT Port is selected.

#### **a. SET THE RECORD DURATION**

- 1) Press [SHIFT] + [REC].
- 2) The display shows current record duration. The second line of the display shows “Enter Record Length” prompt.
- 3) Enter the desired record duration using the ST300’s numeric keypad.
- 4) Press [ENTER] to save the new record duration and exit.

**OR**

Press [ESC] to exit without saving.

**NOTE:** Set Factory Defaults (in the SETUP MENU) sets the record duration to 1 hour.

#### **b. CREATE A NEW NAME**

- 1) Press [CLIP LIST]. The CLIP LIST indicator turns on. The display will show “CREATE NEW CLIP.”
- 2) Press [LOAD]. The display will show the default CLIP ID.
- 3) Press [LOAD] to accept the default CLIP ID.

**OR**

Use [NEXT CUE], [LAST CUE] and Wheel to create a CLIP ID. Use the [NEXT CUE] and [LAST CUE] keys to position the cursor. Turn the Wheel to select the desired letter.

**OR**

Create an ID using the numeric keypad, with a maximum of eight characters if extended IDs are OFF, and maximum of 20 characters if extended IDs are ON. Press [ENTER].

- 4) Press [LOAD] to create the selected CLIP ID. If the selected CLIP ID already exists, a warning message will be displayed. To load the existing clip, press [ENTER]. Press [ESC] to exit without loading the existing clip.

### **c. RECORD A CLIP**

**NOTE:** To record a clip, the video server must have enough memory to record the entire clip. Video input must be connected to the Record Channel.  
The ST300 Port selected for recording must be an Input Port [a "-" (minus) number].

- 1) Set the desired record duration as described in Section 11.a., "**SET THE RECORD DURATION.**"
- 2) Create a new name as described above in Section 11.b., "**CREATE A NEW NAME.**"
- 3) Press [**RECORD**] to start recording.
- 4) Press [**STOP**] to stop recording.

## 12. CREATING SUBCLIPS

### a. MARK IN (OUT) POINT

- 1) Press **[IN]** (**[OUT]**) key.
- 2) The current Timecode is saved as **[IN]** (**[OUT]**) point. **IN** (**[OUT]**) indicator turns on.

### b. DELETE IN (OUT) POINT

- 1) Press **[DEL]** key and **[IN]** (**[OUT]**) key
- 2) The **[IN]** (**[OUT]**) point is cleared. The **[IN]** (**[OUT]**) indicator is turned off.

### c. MANUALLY ENTER IN (OUT) POINT

- 1) Press **[SHIFT]** and **[IN]** (**[OUT]**) key.
- 2) The display prompts to enter new **[IN]** (**[OUT]**) point
- 3) Type in the new timecode using numeric keypad.
- 4) Press **[ENTER]** to save the new **[IN]** (**[OUT]**) point.  
**OR**

Press **[ESC]** to leave without saving

**OR**

Press **[RECUE]** to save the new **[IN]** (**[OUT]**) point and recue to it.

### d. CREATE SUBCLIP

- 1) Mark or Enter **IN** and **OUT** points as described above
- 2) Press **[SHIFT]** + **[CLIP LIST]** keys.
- 3) The display prompts to enter a subclip name.
- 4) Enter the name using the Shotbox keyboard or the numeric keypad
- 5) Press **[ENTER]**.
- 6) The subclip with the specified name and the IN and OUT points is created.

### **13. RECUE THE CURRENTLY LOADED CLIP**

- a. Press **[RECUE]** to reload the currently loaded clip to the IN point.
- b. Press **[SHIFT] + [RECUE]**.  
The display will show: “xx:xx:xx:xx”  
(Where xx:xx:xx:xx = Last entered RECUE time.)  
“Enter RECUE time”  
Enter the time using the ST300’s numeric keypad.  
  
Press **[ENTER]** to reload the currently loaded clip at the entered time.  
**OR**  
  
Press **[ESC]** to exit without searching.

### **14. VIEW THE CLIP ID OF THE CURRENTLY LOADED CLIP**

- a. Press and hold **[SHIFT]**, then press and release **[LOAD]**.
- b. The bottom line will show: “Loaded Clip: xxxxxxxx”  
where xxxxxxxx is the CLIP ID.

## 15. VIEW CONTENT OF CUE POINTS ON THE SHOTBOX

- a. Press **[VIEW]**. The VIEW indicator comes on.
- b. Press the switch for which you would like to see the content.
- c. The switch turns RED and the content (CLIP ID) of the corresponding Cue Point is displayed on a virtual display.

For Example:

<b>VTR 1</b> <b>Clip 23</b>
--------------------------------

<b>VTR 2</b> <b>Clip 13</b>
--------------------------------

<b>VTR 3</b> <b>Clip 77</b>
--------------------------------

<b>VTR 4</b> <b>No Assignment</b>
--------------------------------------

Note: All the remaining switches are not illuminated.

- d. Release the keys to return to normal operation.

## 16. SHOTBOX CONTROL SWITCHES

- a. **[PLAY]**: Plays out the selected clip.
- b. **[RECUE]**: Returns to the beginning of the clip.
- c. **[STOP]**: Stops playout of the clip.

## 17. CLEAR SINGLE CUEPOINT

On the Shotbox, press **[SHIFT]** + the Shotkey, the content of which you wish to clear. The Shotkey becomes blank, the corresponding cuepoint is cleared.

## 18. TRANSFERRING CUELISTS

The TRANSMIT CUELIST function allows you to transmit your list of Cue Points to a PC, using the provided utility software on the PC, or to another ST300. Transfer to a PC requires OpSuite 3.0 software, which runs on a Windows-based computer. Contact DNF Controls for more information.

### a. TO TRANSMIT CUE POINTS TO THE ST300

- 1) Connect the VTR4 connector on the rear of the ST300 to the VTR4 connector of the receiving ST300 using an RS422 9-pin cable with TX and RX lines crossed. (A “turnaround” cable)
- 2) Press [**MENU**].
- 3) Scroll the Wheel until “Transmit CUE List? YES=Enter, Exit=ESC” is displayed.
- 4) Press [**ENTER**] to start transmitting.  
The Display shows “Waiting to transmit” on the first line.
- 5) When the Receiver is ready, transfer starts automatically.  
The Display now shows “Transmitting cuelist.”
- 6) After the transfer is over, the display shows “Transfer is over” for one second and then shows “Waiting to transmit” again.
- 7) Connect another ST300 to transmit the list again.

**OR**

Press [**ESC**] twice to exit the MENU mode.

### b. TO TRANSMIT CUE POINTS TO THE PC

- 1) Connect the VTR4 connector on the back of the ST300 to one of the COM ports on the PC using a RS422 to RS232 adapter.
- 2) Repeat steps 2-7 of the **TO TRANSMIT CUE POINTS TO THE ST300** section.

## 19. RECEIVE CUELIST FUNCTION.

The RECEIVE CUELIST function allows you to receive your list of Cue Points from a PC or from another ST300. Transfer to a PC requires OpSuite 3.0 software, which runs on a Windows-based computer. Contact DNF Controls for more information.

### a. TO RECEIVE CUE POINTS FROM THE ST300

- 1) Connect the VTR4 connector on the back of the ST300 from the VTR4 connector of the transmitting ST300 using RS422 9-pin cable with TX and RX lines crossed.  
(A “Turnaround” Cable)
- 2) Press [MENU].
- 3) Scroll the Wheel until “Receive CUE List? YES=Enter, Exit=ESC” is displayed.
- 4) Press [ENTER] to start receiving.  
The Display shows “Waiting to receive” on the first line.
- 5) When the Transmitter is ready, transfer starts automatically.  
The Display now shows “Receiving cue list.”
- 6) After the transfer is over the display shows “Done-Success! Press any key...”
- 7) Press any key. The display shows “Receive cue list?” message.
- 8) Press [ESC] to exit the MENU mode.

### b. TO RECEIVE CUE POINTS FROM THE PC

- 1) Connect the VTR4 connector on the back of the ST300 to one of the COM ports on the PC using RS422 to RS232 adapter.
- 2) Repeat steps 2-8 of the **TO RECEIVE CUE POINTS FROM THE ST300** section.

## Reference . . .

### 20. SETUP MENU

- ❑ Press [MENU]. The MENU indicator will turn on.
- ❑ Turn the Wheel to select item to change.
- ❑ Press [MENU] **OR** use the Softkeys to change the desired mode for that option.
- ❑ Turn the Wheel at anytime to select another item.
- ❑ Press [ESC] at anytime to exit. The MENU indicator will turn off.

<u>MENU MODES</u>	(Turning Wheel clockwise)
<b>SET LOUTH PORT</b>	Allows user to select Louth Port for each VTR.
<b>RECORD</b>	Press [MENU] to select the desired record mode: Lockout or Crash (Full).
<b>EXTENDED IDs (V3.0 Only)</b>	Toggle Extended IDs ON/OFF. Extended IDs ON allows access up to 32 characters, OFF – up to 8 characters.
<b>CLIP SOM</b>	Press displayed softkey to toggle between “ZERO” and “NOT ZERO.”  Select ZERO if the clips that you are using start with 00:00:00:00.  Select NOT ZERO if the clips that you are using do not start with 00:00:00:00.
<b>RECALL MODE</b>	Press Normal or Redirect (Redir). When one and only one clip is learned into a Cue Point, the Clip will be REDIRECTED to load on the currently selected VTR if REDIR is on.  If REDIR is off, the Clip will be loaded on the VTR it is LEARNED into.
<b>VIDEO STANDARD</b>	Press displayed softkey to select PAL, NTSC (not drop frame), or DF (drop frame).
<b>WIND MODE</b>	Press Softkey to select: HOLD (Fast wind is maintained only while key is depressed.) <b>OR</b> LATCH (Fast wind is initiated and maintained with momentary key press.)  Select fast wind speed (3.9 to 23.7) by pressing Softkey below SPD.

<p><b>SLOMO</b></p>	<p>ST300 display shows (Non T-Bar Version):</p> <table border="1" data-bbox="841 205 1357 321"> <tr> <td>SLOMO with:</td> <td>WHEEL</td> </tr> <tr> <td><b>SpdRange</b></td> <td><b>Preset</b></td> </tr> </table> <p>Press Softkey [<b>SPEED</b>] to select SLOMO speed ranges:  Press Softkey to select: 0 → +200% <b>OR</b> -100 → +200%.  <b>NOTE:</b> 100% is normal speed.</p> <p>Press Softkey [<b>BACK</b>] to return to SLOMO MENU.</p> <p>Press [<b>ESC</b>] to exit SETUP MENU and save changes.  <b>OR</b>  Turn the Wheel to select another item.</p> <p>ST300 display shows (T-Bar Version):</p> <table border="1" data-bbox="841 667 1357 772"> <tr> <td>SLOMO with:</td> <td>TBAR</td> </tr> <tr> <td><b>WHEEL</b></td> <td></td> </tr> </table> <p>Press Softkey [<b>TBAR</b>] (or [<b>WHEEL</b>]) to toggle between them.</p> <p>The T-BAR has a speed range of 0 → +200 with a detent at +100% play speed  <b>OR</b> a range of 0 → +100% (detent at +100% Play speed).  <b>NOTE:</b> 100% is normal speed.</p> <p><b>For Wheel only:</b>  Press Softkey [<b>PRSET</b>] to select the SLOMO Preset Speed Mode.</p> <p>Press Softkey [<b>UPDATE</b>].  When exiting SLOMO mode, the last used speed is saved in the Preset Speed register.</p> <p>Press Softkey [<b>STATIC</b>].  The Preset Speed register is NOT updated when exiting SLOMO mode.</p> <p>It is only changed by [<b>SHIFT</b>] + [<b>SLOMO</b>] (PRESET SLOMO).</p>	SLOMO with:	WHEEL	<b>SpdRange</b>	<b>Preset</b>	SLOMO with:	TBAR	<b>WHEEL</b>	
SLOMO with:	WHEEL								
<b>SpdRange</b>	<b>Preset</b>								
SLOMO with:	TBAR								
<b>WHEEL</b>									
<p><b>ST300 SETUP</b></p>	<table border="1" data-bbox="573 1402 1146 1518"> <tr> <td colspan="2">ST300 SETUP</td> </tr> <tr> <td>Clear Cues</td> <td>SetDefault</td> </tr> </table> <p>Press Softkey beneath ClearCues to clear all Cue Points to 00:00:00:00.  Press Softkey [<b>YES</b>] when asked “Are You Sure?”</p> <p>Press Softkey beneath SetDefault to set ST300 to default settings.  Press Softkey [<b>YES</b>] when asked “Are You Sure?”</p>	ST300 SETUP		Clear Cues	SetDefault				
ST300 SETUP									
Clear Cues	SetDefault								
<p><b>DISPLAY SOFTWARE VERSION</b></p>	<p>The version number for the currently installed software is displayed.</p>								

<b>SYNC ON/OFF</b>	For V3.0 only. Set video sync to ON/OFF.		
<b>RECORD</b>	Press Softkey to select single button or 2-button record. RECORD = [REC] Only <b>OR</b> [REC] + [PLAY].		
<b>PBIO ADDRESS</b>	Press VTR key to assign PBIO address.  Display shows: <table border="1" style="display: inline-table; vertical-align: middle;"><tr><td>PBIO Address = 00</td></tr><tr><td>Enter 00-23</td></tr></table>  Enter address number desired on numeric keypad. Repeat for all VTRs assigned.	PBIO Address = 00	Enter 00-23
PBIO Address = 00			
Enter 00-23			
<b>SWITCHER TYPE</b>	Select your switcher type: GVG = Grass Valley Group (default) or Sony. For Phillips DD35 with PBus, use GVG.		
<b>PARITY</b>	Select ODD, EVEN or NONE. This is the parity sent via the Peripheral Bus (PBIO) to the ST300.		
<b>PREROLL</b>	Enter Preroll value.		
<b>TRANSMIT CUELIST</b>	Transmits Cuelist to another ST300 or to a PC.		
<b>RECEIVE CUELIST</b>	Receives Cuelist from another ST300 or a PC.		

## 21. FUNCTION TABLE

Function	Key Press	Description
GOTO ENTERED TIME	[SHIFT] + [RECUE]	Search the VTR to the manually entered time.  Use the ST300 numeric keypad. Press [ENTER] or [RECUE].  NOTE: Use 00:00:00:00 to recue a clip to ET=0 if start time is not ET=0
GANG	[SHIFT] + [VTR #1] OR [SHIFT] + [VTR #2] OR [SHIFT] + [VTR #3]	Individually press the VTR keys to be included in the gang. The LED above the key will turn on. Press the VTR key again to remove from gang, the LED above the key will turn off. Press [ESC] to exit.  The VTR LEDs that are on show the gang. The flashing LED shows which VTR is currently selected.
FFWD	[FFWD]	Press and HOLD to shuttle. Release key to stop. Set WIND Speed in MENU.
JOG	[JOG]	Select JOG mode and enable Wheel.
LAST CUE	[LAST CUE]	Step to the previous Cue Point Location.
NEXT CUE	[NEXT CUE]	Step to the next Cue Point Location.
RECORD	[REC]	Places VTR into the Record mode selected by RECORD MODE in the SETUP MENU. Press [RECORD] OR [RECORD] + [PLAY].
REWIND	[RWD]	Press and HOLD to shuttle. Release key to stop. Set WIND Speed in MENU.
SHUTTLE	[SHUTTLE]	Select SHUTTLE mode and enable Wheel.
SLOMO	[SLOMO]	Press [SLOMO] to slo-mo the VTR. Turn the Wheel (or move the T-Bar, if available) to change the play speed. Press [SLOMO] to STILL frame. <b>OR</b> Press any transport key to exit SLOMO.
SLO-MO SPEED PRESET	[SHIFT] + [SLOMO]	For WHEEL ONLY: Press [SHIFT] + [SLOMO] to preset the slo-mo speed. Turn the Wheel to select desired speed. Press [ESC] or any transport key to exit.
STOP	[STOP]	Press once to STILL frame VTR. Press again to put VTR into STOP mode.
TIME MODE SELECT	[TIME MODE]	Press to toggle between ET (Elapsed Time) and RT (Running Time) display modes.

## 22. SPECIFICATIONS

### ST300

Power:	90 VAC to 265 VAC adapter supplied with IEC connector
Size:	(L" x W" x H") 10 1/2" x 6" x 1 1/2" (front) 3.0" (rear) (-T Bar Version) (L" x W" x H") 12 5/8" x 6" x 1 1/2" (front) 3.0" (rear)
Weight:	4 lbs.
Rear Panel Connectors:	VTR1, VTR2, VTR3, VTR4 ..... All DB9F GPI..... DBF15F Power ..... DB9M Aux ..... DB9F
Display:	Easy to read 2-line, back-lit LCD display (User adjustable contrast)
Jog/Shuttle Wheel:	With mechanical detents.
Optional "T"-bar:	Slo-mo 0-200% of Play Speed (2X Normal Speed)

### RS422 SERIAL CONNECTOR 9-Pin D-Type, Female (VTR1-VTR4)

Pin #	1	Frame Ground	6	Receive Common
	2	Receive A ←	7	Receive B ←
	3	Transmit B →	8	Transmit A →
	4	Transmit Common	9	Frame Ground
	5	Spare		

### POWER CONNECTOR 9-Pin D-Type, Male

Pin #	1	+5v DC	6	+5 VDC
	2	+5v DC	7	Ground
	3	Ground	8	Ground
	4	+12 VDC	9	Ground
	5	-12 VDC		

### AUX PORT RS422 SERIAL CONNECTOR 9-Pin D-Type, Female

Pin #	1	Frame Ground	6	Transmit Common
	2	Receive A ←	7	Receive B ←
	3	Transmit B →	8	Transmit A →
	4	Receive Common	9	Frame Ground
	5	Spare		

## GPI IN/OUT CONNECTOR

### 15-Pin D-Type, Female (DB15F)

Pin #	1	GPI OUT 1	9	PLAY
	2	GPI OUT 2	10	STOP
	3	GPI OUT 3	11	RECUE
	4	GPI OUT 4	12	NEXT CUE
	5	GPI OUT 5	13	LAST CUE
	6	GPI OUT 6	14	RECALL
	7	GPI OUT 7	15	GPI 7 IN (disabled)
	8	Ground		

## ST420 (SHOTBOX)

Power: 90 VAC to 265 VAC adapter supplied with IEC connector

Size: [L" x W" x H"] 12" x 7.25" x 1.5" (front) 3.5" (rear)

Weight: 5.5 lbs.

Rear Panel Connectors: Power ..... DB9M  
 OUTPUT ..... DB9F  
 Aux ..... DB9F

Display: Six characters on each of three lines on each Shotkey.  
 Liquid Crystal Display

## RS422 SERIAL CONNECTOR

### 9-Pin D-Type, Female ("OUTPUT")

Pin #	1	Frame Ground	6	Transmit Common
	2	Transmit A →	7	Transmit B →
	3	Receive B ←	8	Receive A ←
	4	Receive Common	9	Frame Ground
	5	Spare		

## POWER CONNECTOR

### 9-Pin D-Type, Male

Pin #	1	+5v DC	6	No Connection
	2	+5v DC	7	Ground
	3	Ground	8	Ground
	4	No Connection	9	Ground
	5	No Connection		

**NOTE:** The GPI connector and OUTPUT 2 are not used with this System.

## 23. TROUBLESHOOTING

### a. ST420 TROUBLESHOOTING

- 1) All keys are RED - no communication with ST300.
- 2) All keys are dark - no communication between the ST300 and the Video Server.
- 3) The version of the ST420 must comply in the software version with the ST300 it is connected to.

To determine the software version of the ST420 do the following:

- a) Press **[SHIFT]** + **[STOP]** + **[PLAY]**.  
The key that displays the current version is RED.
- b) The ST420 displays:  
“SELECT ST300 V2.1 or V2.0 or V3.0.”

Press the key for the software version of the ST300 you are using.  
Please refer to the ST300 to determine the version if needed.

### b. VERSION 3.0 HARDWARE OF ST300 ONLY

#### VIDEO REFERENCE SETUP

Plug the video reference BNC cable into the BNC connector on the back of the ST300.

Plug the same video reference into the SYNC IN connector on the rear of the Video Server.

Press **[MENU]**.

- 1) Turn the Wheel until the display says “SYNC.”
- 2) Press the Softkeys to toggle between SYNC ON and OFF. (Default = ON)

Installing sync into the ST300 and the Video Server, and selecting Sync ON will help assure that several channels in the gang will roll in sync.  
(For example, Fill and Key.)

# 24. KEY LAYOUT

## ST300 KEY CONFIGURATION 2034CL-L & 4000CL-L V3.0 (& -I, & -PBIO)

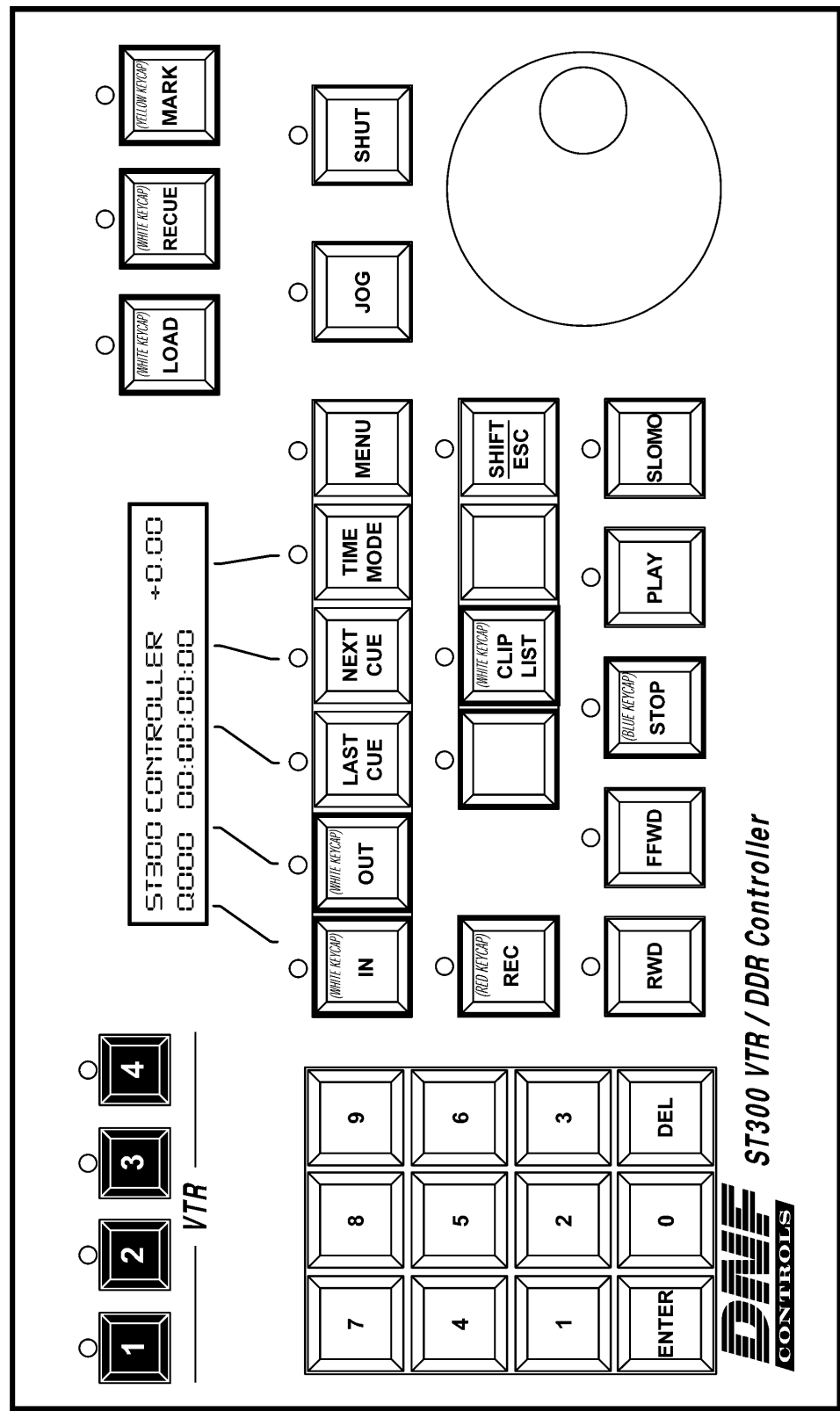

## **25. DNF CONTROLS LIMITED WARRANTY**

DNF Controls warrants its product to be free from defects in material and workmanship for a period of one (1) year from the date of sale to the original purchaser from DNF Controls.

In order to enforce the rights under this warranty, the customer must first contact DNF's Customer Support Department to afford the opportunity of identifying and fixing the problem without sending the unit in for repair. If DNF's Customer Support Department cannot fix the problem, the customer will be issued a Returned Merchandise Authorization number (RMA). The customer will then ship the defective product prepaid to DNF Controls with the RMA number clearly indicated on the customer's shipping document. The merchandise is to be shipped to:

DNF Controls  
12843 Foothill Blvd., Suite D  
Sylmar, CA 91342  
USA

Failure to obtain a proper RMA number prior to returning the product may result in the return not being accepted, or in a charge for the required repair.

DNF Controls, at its option, will repair or replace the defective unit. DNF Controls will return the unit prepaid to the customer. The method of shipment is at the discretion of DNF Controls, principally UPS Ground for shipments within the United States of America. Shipments to international customers will be sent via air. Should a customer require the product to be returned in a more expeditious manner, the return shipment will be billed to their freight account.

This warranty will be considered null and void if accident, misuse, abuse, improper line voltage, fire, water, lightning or other acts of God damaged the product. All repair parts are to be supplied by DNF Controls, either directly or through its authorized dealer network. Similarly, any repair work not performed by either DNF Controls or its authorized dealer may void the warranty.

After the warranty period has expired, DNF Controls offers repair services at prices listed in the DNF Controls Price List. DNF Controls reserves the right to refuse repair of any unit outside the warranty period that is deemed non-repairable.

DNF Controls shall not be liable for direct, indirect, incidental, consequential or other types of damage resulting from the use of the product.

###