



12843 Foothill Blvd.,
Suite D
Sylmar, CA 91342
818 898 3380 voice
818 898 3360 fax
www.dnfcontrols.com

Model 4000CL-BVW 400 CLIP FAST ACCESS SYSTEM

WITH

**BVW PROTOCOL
FOR PROFILE VIDEO SERVERS ONLY**

VERSION 3.0 SOFTWARE

USER MANUAL

Table of Contents

1. REVISION HISTORY	3
<i>GETTING STARTED . . .</i>	<i>4</i>
2. SYSTEM DESCRIPTION	4
3. SYSTEM INSTALLATION	5
ST300-S/SM, VTR/DDR CONTROLLER	5
4. VIDEO SERVER SETUP	6
5. LOAD A CLIP	6
6. VIEW THE CLIP ID OF THE CURRENTLY LOADED CLIP	6
7. LEARN A CLIP OR CLIP COMBINATION	7
8. RECALL A CLIP OR CLIP COMBINATION	7
9. RECUE THE CURRENTLY LOADED CLIP	7
<i>ADVANCED FEATURES . . .</i>	<i>8</i>
10. CREATE A CLIP	8
11. TRIM A CLIP	8
a. SETTING THE IN (OUT) POINT	8
b. VIEW THE IN (OUT) POINT	8
c. CLEARING AN IN (OUT) POINT	9
d. TRIMMING A CLIP	9
12. CAPTURE FUNCTION	9
a. SETTING THE IN (OUT) POINT	9
b. ENTER PREROLL VALUE	9
13. TRANSFER CUE LIST	10
a. TRANSMIT CUE LIST FUNCTION	10
b. RECEIVE CUE LIST FUNCTION	11
<i>REFERENCE . . .</i>	<i>12</i>
14. SETUP MENU	12
15. FUNCTION TABLE	14
16. SPECIFICATIONS	15
17. KEY LAYOUT	17
18. DNF CONTROLS LIMITED WARRANTY	18

Manual Version..... 1.6 080604
Document No..... 4000CL-BVW User Manual

1. REVISION HISTORY

120502	Rev. 1.1	Changed Key Layout
042803	Rev. 1.2	Added "For Profile Video Servers Only" to cover.
052003	Rev. 1.3	Added Section 13. CAPTURE FUNCTION, removed Section 10, LOOP CLIP, revised Key Layout.
100903	Rev. 1.4	Company header information revised.
112103	Rev. 1.5	Updated Transmit Cue List and Receive Cue List Function description. Added DNF Controls Limited Warranty.
080604	Rev. 1.6	Changed T-bar dimension.

Getting Started . . .

2. SYSTEM DESCRIPTION

The 4000CL-BVW system includes DNF's most popular controller, the ST300, with Cliplist software. The ST300 controls up to 4 video channels individually or ganged. It features full transport functionality.

The 4000CL-BVW provides fast access to fill clip and key clip combinations with the press of one key.

The 4000CL-BVW supports BVW Broadcast protocol and requires that the VDR panel on the Profile be set to BVW.

The 4000CL-BVW provides fast access to existing video clips stored in the Grass Valley Group PROFILE.

DEFINITIONS:

- Throughout this document, the Grass Valley Profile will be referred to as "Video Server."
- The ST300-S/SM is referred to as "ST300."
- Words surrounded by brackets, for example [ENTER], are keys on the ST300. [XXX] + [XXX] means hold the two keys down simultaneously. XXX = Key name.

3. SYSTEM INSTALLATION

ST300-S/SM, VTR/DDR CONTROLLER

- a. Plug one end of a 9-conductor, RS422 serial cable into the VTR 1 (2, 3 or 4) connector on the rear of the ST300. Plug the other end of the cable into the REMOTE connector on the Video Server.
- b. Connect the supplied POWER SUPPLY, APX#4108, into the POWER connector on the rear of the ST300. Plug the Power Supply into an outlet, 90 VAC – 240 VAC.
- c. Check SETUP MENU prior to using the ST300 to confirm proper Record mode and other User settable modes.

Installation is complete.

CONNECTION DIAGRAM

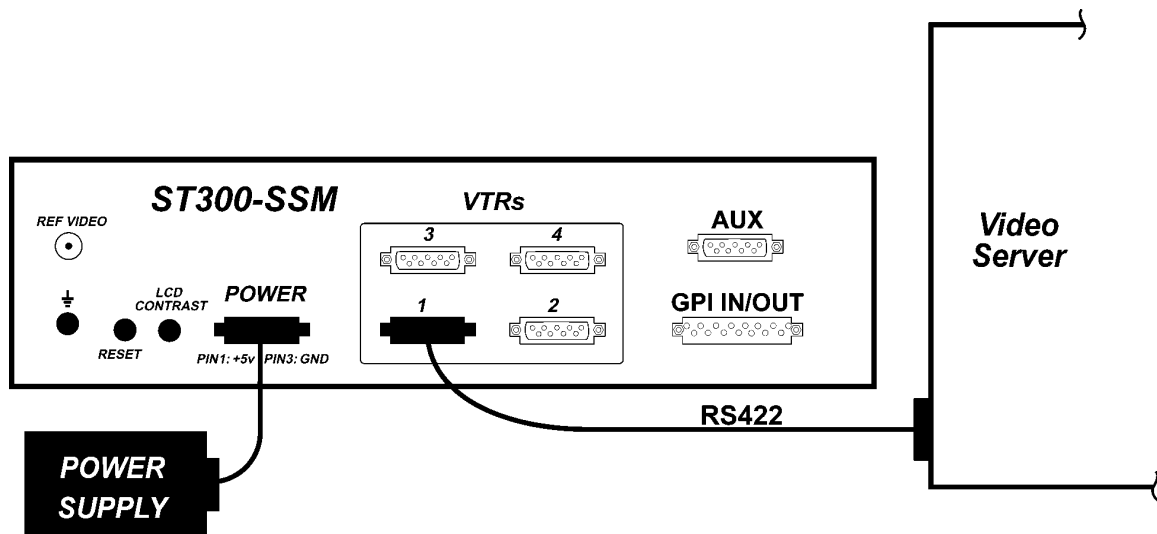

4. VIDEO SERVER SETUP

- a. Select BVW protocol on the VIDEO SERVER to be controlled.
- b. Assign a serial port on the VIDEO SERVER through which the ST300 will control the server.

Setup is complete.

5. LOAD A CLIP

- a. Select a VTR by pressing VTR [1], VTR [2], VTR [3], or VTR [4].
- b. Press [CLIP LIST] to view the list of CLIP IDs that are resident on the Video Server. The CLIP LIST indicator will turn on.
- c. Press [CREATE] to create and load a new clip.
(Creating a clip is described in the CREATING A CLIP section.)
OR

Turn the Wheel to view the existing CLIP IDs on the video server.

Turn the Wheel clockwise to scroll forward, or counter-clockwise to scroll backward, through the list of available CLIPs. Backward scrolling is limited to the last 10 CLIP IDs viewed.

OR

Manually enter a CLIP ID using the ST300 numeric keypad, or PC keyboard (if KBIO option).

- d. Press [LOAD] to load the selected CLIP ID for playout.
- e. Repeat steps a. - d. to load clips on desired VTRs.
- f. Set the GANG mode, if required.

6. VIEW THE CLIP ID OF THE CURRENTLY LOADED CLIP

Press [SHIFT] + [LOAD]. The bottom line of the display will show the name of the loaded clip.

7. LEARN A CLIP OR CLIP COMBINATION

- a. Load a clip on the desired VTRs (See Section 5, “LOAD A CLIP”).
- b. Select the desired Cue Point by pressing [NEXT CUE], [LAST CUE] or by manually entering the Cue Point using the numeric keypad. The selected Cue Point number is shown on the bottom line of the display.
- c. Press [SHIFT] + [MARK] to start the LEARN. The first line of the display will show “Select VTRs:” The second line of the display will show “Mark-Lrn, ESC-cancel.”
- d. Press VTR [1], [2], [3] or [4] to select the VTR to be learned into the current Cue Point. If the VTRs are ganged, select one VTR that is part of the Gang. The rest of the Gang will be learned automatically.
- e. Press [MARK] to complete the LEARN
OR

Press [ESC] to exit without LEARNING.

The ST300 will: LEARN (save) the VTR Number (1,2,3,4), loaded CLIP ID and current IN time to the selected Cue Point.

8. RECALL A CLIP OR CLIP COMBINATION

- a. Select the desired Cue Point by pressing [NEXT CUE], [LAST CUE] or by manually entering the Cue Point using the numeric keypad.

The selected Cue Point number is shown on the bottom line of the display.

- b. Press [LOAD] on the ST300.

The ST300 will automatically load the Learned clips on the Learned VTRs, cue the clips to the Learned time, then set the Learned GANG mode.

9. RECUE THE CURRENTLY LOADED CLIP

Press [RECUE]. If an IN Point is marked (the IN indicator is on), the clip will RECUE to the IN Point.

If the IN point is not marked, the clip will RECUE to the start of the clip.

OR

Press [SHIFT] + [RECUE].

- a. Enter the desired time to search to using the ST300’s numeric keypad.
- b. Press [ENTER] to search to the entered time.
OR

Press [ESC] to exit without searching.

Advanced Features . . .

10. CREATE A CLIP

- a. Press **[CLIP LIST]**. The CLIP LIST indicator turns on. The display will show “CREATE NEW CLIP.”
- b. Press **[LOAD]**. The display will show the default CLIP ID.
- c. Press **[LOAD]** to accept the default CLIP ID.

OR

Use **[NEXT CUE]**, **[LAST CUE]** and Wheel to create a CLIP ID. Use the **[NEXT CUE]** and **[LAST CUE]** keys to position the cursor. Turn the Wheel to select the desired letter.

OR

Create an ID using the numeric keypad, with a maximum of eight characters. Press **[ENTER]**.

- d. Press **[LOAD]** to create the selected CLIP ID. If the selected CLIP ID already exists, a warning message will be displayed. To load the existing clip, press **[ENTER]**. Press **[ESC]** to exit without loading the existing clip.

11. TRIM A CLIP

a. SETTING THE IN (OUT) POINT

- 1) Locate the clip to the desired IN (OUT) time.
- 2) Press **[IN]** (**[OUT]**) to set the IN (OUT) Point. The IN (OUT) indicator will turn on. The display will show “IN (OUT) xx:xx:xx:xx.”

OR

Press **[SHIFT] + [IN]** (**[OUT]**) to manually enter a new IN (OUT) time.

- 3) Press **[ENTER]** to save the entered time or press **[ESC]** to exit without saving.

b. VIEW THE IN (OUT) POINT

- 1) When the IN (OUT) indicator is on, Press **[IN]** (**[OUT]**) to view the existing IN (OUT) Point.
- 2) While viewing the IN (OUT) Point:
 - Press **[MARK]** to overwrite the saved time with the current time.
 - Press **[RECUE]** to search to the IN (OUT) point.

c. CLEARING AN IN (OUT) POINT

Press and hold [DEL] then press and release [IN] ([OUT]). The IN (OUT) indicator turns off.

d. TRIMMING A CLIP

- 1) Mark an IN (OUT) Point as described in 11.a.
- 2) Press [SHIFT] + [CLIP LIST]. The display prompts:
“Save Trim Clip? Load – Save, Esc – Cancel”
- 3) Press [LOAD] to save the loaded clip with new IN (OUT) points.
OR

Press [ESC] to abort.

12. CAPTURE FUNCTION

The CAPTURE function allows source material from a VTR to be easily and quickly recorded into the VIDEO SERVER. A CLIP ID is also created.

VTR1 is always the Recorder (the VIDEO SERVER).

Select VTR [2], VTR [3] or VTR [4] as the source VTR. Any RS422, SONY protocol compatible VTR can be used.

Use the transport function keys to control the source VTR. Each source VTR has its own set of IN and OUT points.

a. SETTING THE IN (OUT) POINT

Set IN and OUT points as described in Section 11, para. a, b, c.

b. ENTER PREROLL VALUE

- 1) Press [MENU] and turn the Wheel to “Enter PREROLL:”
- 2) Enter the desired preroll value using the ST300’s numeric keypad.
- 3) Press [ENTER] to save the entered value.
OR

Press [ESC] to exit without saving.

13. TRANSFER CUE LIST

a. TRANSMIT CUE LIST FUNCTION

The TRANSMIT CUE LIST function allows you to transmit your list of Cue Points to a PC, using the provided utility software on the PC, or to another ST300. Transfer to a PC requires OpSuite 3.0 software, which runs on a Windows-based computer. Contact DNF Controls for more information.

1) To Transmit Cue Points to Another ST300:

- a) Connect the VTR4 connector on the rear of the ST300 to the VTR4 connector of the receiving ST300 using an RS422 9-pin cable with TX and RX lines crossed. (A “turnaround” cable.)
- b) Press [MENU].
- c) Scroll the Wheel until “Transmit CUE list? YES=Enter, Exit=ESC” is displayed.
- d) Press [ENTER] to start transmitting. The Display shows “Waiting to transmit” on the first line.
- e) When the Receiver is ready, transfer starts automatically. The Display now shows “Transmitting cuelist.”
- f) After the transfer is over, the display shows “Transfer is over” for one second and then shows “Waiting to transmit” again.
- g) Connect another ST300 to transmit the list again
OR
Press [ESC] twice to exit the MENU mode.

2) To Transmit Cue Points to a PC:

- a) Connect the VTR4 connector on the back of the ST300 to one of the COM ports on the PC using a RS422 to RS232 adapter.
- b) Repeat steps a) - g) of “To Transmit Cue Points to Another ST300,” Section 13.a.1).

b. RECEIVE CUE LIST FUNCTION

The RECEIVE CUELIST function allows you to receive a list of Cue Points from a PC or from another ST300. Transfer to a PC requires OpSuite 3.0 software, which runs on a Windows-based computer. Contact DNF Controls for more information.

1) To Receive Cue Points From Another ST300

- a) Connect the VTR4 connector on the back of the ST300 from the VTR4 connector of the transmitting ST300 using RS422 9-pin cable with TX and RX lines crossed.
(A "Turnaround" Cable)
- b) Press [MENU].
- c) Scroll the Wheel until "Receive CUE List? YES=Enter, Exit=ESC" is displayed.
- d) Press [ENTER] to start receiving.
The Display shows "Waiting to receive" on the first line.
- e) When the Transmitter is ready, transfer starts automatically.
The Display now shows "Receiving cuelist."
- f) After the transfer is over the display shows "Done-Success! Press any key..."
- g) Press any key. The display shows "Receive cuelist?" message.
- h) Press [ESC] to exit the MENU mode.

2) To Receive Cue Points From the PC

- a) Connect the VTR4 connector on the back of the ST300 to one of the COM ports on the PC using RS422 to RS232 adapter.
- b) Repeat steps a) – h) of "**To Receive Cue Points From Another ST300,**" Section 13.b.1.

Reference . . .

14. SETUP MENU

Press [MENU]. The MENU indicator will turn on.

Turn the Wheel to select item to change.

Press [MENU] **OR** use the Softkeys to change the desired mode for that option.

Turn the Wheel at anytime to select another item.

Press [ESC] at anytime to exit SETUP MENU. The MENU indicator will turn off.

<u>MENU MODES</u>	<u>(Turning Wheel Clockwise)</u>
RECORD	Press Softkey to select the desired record mode: Assemble, Insert, Lockout or Crash (Full).
WIND MODE	Press Softkey to select: HOLD (fast wind is maintained only while key is depressed). OR LATCH (fast wind is initiated and maintained with momentary key press). Select fast wind speed (03.9X, etc.) by pressing Softkey.
SLOMO	<div style="display: flex; justify-content: space-between;"> <div style="width: 45%;"> <p>ST300 display shows (Non T-Bar version):</p> </div> <div style="width: 50%; border: 1px solid black; padding: 5px;"> <p>SLOMO with: WHEEL</p> <p>SpdRange Preset</p> </div> </div> <div style="display: flex; justify-content: space-between; margin-top: 10px;"> <div style="width: 45%;"> <p>ST300 display shows (T-Bar version):</p> </div> <div style="width: 50%; border: 1px solid black; padding: 5px;"> <p>SLOMO with: TBAR</p> <p>Wheel SpdRange Preset</p> </div> </div> <p>Press Softkey [TBAR] (or [WHEEL]) to toggle between T-BAR and WHEEL.</p> <p>NOTE - The T-BAR has a fixed speed range of 0 → +200 with a detent at +100% play speed.</p> <p>For Wheel only: Press Softkey [SPDRANGE] to select SLOMO speed ranges:</p> <p>Press Softkey to select 0 → +200 OR -100 → +200. Press Softkey [BACK] to return to SLOMO MENU.</p> <p>Press [ESC] to exit SETUP MENU OR turn the Wheel to select another item.</p> <p>(Continued on next page.)</p>

	<p>For Wheel only: Press Softkey [PRSET] to select the SLOMO Preset Speed Mode.</p> <p>Press Softkey [UPDATE]. When exiting SLOMO mode, the last used speed is saved in the Preset Speed register.</p> <p>OR Press Softkey [STATIC]. The Preset Speed register is NOT updated when exiting SLOMO mode. It is only changed by [SHIFT] + [SLOMO] (PRESET SLOMO).</p>
<p>ST300 SETUP</p>	<div data-bbox="477 508 1050 625" style="border: 1px solid black; padding: 5px; margin-bottom: 10px;"> <p style="text-align: center;">ST300 SETUP</p> <p style="text-align: center;">Clear Cues SetDefault</p> </div> <p>Press Softkey beneath ClearCues to clear all Cue Points to 00:00:00:00. Press Softkey [YES] when asked “Are You Sure?”</p> <p>Press Softkey beneath SetDefault to set ST300 to default settings. Press Softkey [YES] when asked “Are You Sure?”</p> <p>IMPORTANT NOTE: Please set these items during initial installation.</p>
<p>DISPLAY SOFTWARE VERSION</p>	<p>The version number and date for the currently installed software is displayed. For example:</p> <div data-bbox="724 947 1222 1052" style="border: 1px solid black; padding: 5px; margin: 10px auto; width: fit-content;"> <p style="text-align: center;">4000CL-B V3.0</p> <p style="text-align: center;">mm/dd/yy</p> </div>
<p>RECORD</p>	<p>Press Softkey to select single button or 2-button record. RECORD = [REC] Only.</p> <p>OR [REC] + [PLAY].</p>
<p>TRANSMIT CUELIST</p>	<p>Transmit Cuelist to another ST300 or to a PC. See Section 13, “Transfer Cue List.”</p>
<p>RECEIVE CUELIST</p>	<p>Receive Cuelist from another ST300 or a PC. See Section 13, “Transfer Cue List.”</p>

15. FUNCTION TABLE

FUNCTION	KEY PRESS	DESCRIPTION
GOTO ENTERED TIME	[SHIFT] + [RECUE]	Search the VTR to the manually entered time. Use the ST300 numeric keypad. To manually enter the desired time press [ENTER] or [RECUE]. NOTE: GRASS VALLEY GROUP Profile does not support TC or VITC time search.
GANG	[SHIFT] + [VTR #1] OR [SHIFT] + [VTR #2] OR [SHIFT] + [VTR #3] OR [SHIFT] + [VTR #4]	Individually press the VTR keys to be included in the gang; the LED above the key will turn on. Press the VTR key again to remove from gang; the LED above the key will turn off. Press [ESC] to exit. The VTR LEDs that are on show the gang. The flashing LED shows which VTR is currently selected.
FFWD	[FFWD]	Press and HOLD to FFWD. Release key to stop. Set WIND Speed in MENU.
JOG	[JOG]	Select JOG mode and enable Wheel.
LAST CUE	[LAST CUE]	Step to the previous Cue Point Location.
LOOP	[SHIFT] + [PLAY]	Play the currently loaded clip in a continuous loop.
NEXT CUE	[NEXT CUE]	Step to the next Cue Point Location.
RECORD	[REC]	Places VTR into the Record mode selected by RECORD MODE in the SETUP MENU. Press [RECORD] or [RECORD] + [PLAY].
REWIND	[RWD]	Press and HOLD to REWIND. Release key to stop. Set WIND Speed in MENU.
SHUTTLE	[SHUTTLE]	Select SHUTTLE mode and enable Wheel.
SLOMO	[SLOMO]	Press [SLOMO] to slo-mo the VTR. Turn the Wheel (or move the T-Bar, if available) to change the play speed. Press [SLOMO] to STILL frame OR press any transport key to exit SLOMO.
SLO-MO SPEED PRESET	[SHIFT] + [SLOMO]	For WHEEL ONLY : Press [SHIFT] + [SLOMO] to preset the slo-mo speed. Turn the Wheel to select desired speed. Press [ESC] or any transport key to exit.
STOP	[STOP]	Press once to STILL frame VTR. Press again to put VTR into STOP mode.
TIME MODE SELECT	[TIME MODE]	Press to toggle between Timecode (TC), VITC (VT) or Tape Timer (TM) display modes.

16. SPECIFICATIONS

ST300

Power:	90 VAC to 265 VAC adapter supplied with IEC connector		
Size:	(L" x W" x H") 12" x 6" x 1.5" (front) 3.0" (rear) (T-Bar unit is 12.6" long)		
Weight:	4 lbs.		
Rear Panel Connectors:	VTR1, VTR2, VTR3, VTR4	(All DB9F)	
	GPI	(DBF15F)	
	Power	(DB9M)	
	Aux	(DB9F)	
	Reference Video	(BNC)	
Display:	Easy to read 2-line, back-lit LCD display (User adjustable contrast)		
Jog/Shuttle Wheel:	With mechanical detents.		
Optional "T"-bar:	Slo-mo 0-200% of Play Speed		

VTR RS422 SERIAL CONNECTOR

9-Pin D-Type, Female

Pin #	1	Frame Ground	6	Receive Common
	2	Receive A ←	7	Receive B ←
	3	Transmit B →	8	Transmit A →
	4	Transmit Common	9	Frame Ground
	5	Spare		

POWER CONNECTOR

9-Pin D-Type, Male

Pin #	1	+5v DC	6	+5 VDC
	2	+5v DC	7	Ground
	3	Ground	8	Ground
	4	+12 VDC	9	Ground
	5	-12 VDC		

AUX PORT RS422 SERIAL CONNECTOR

9-Pin D-Type, Female

Pin #	1	Frame Ground	6	Receive Common
	2	Receive A ←	7	Receive B ←
	3	Transmit B →	8	Transmit A →
	4	Receive Common	9	Frame Ground
	5	Spare		

GPI IN/OUT CONNECTOR

15-Pin D-Type, Female (DB15F)

Pin #	Description	Function	Pin #	Description	Function
1	GPI 1 Out		9	GPI 1 In	Play
2	GPI 2 Out		10	GPI 2 In	Stop
3	GPI 3 Out		11	GPI 3 In	Recue
4	GPI 4 Out		12	GPI 4 In	Next Cue
5	GPI 5 Out		13	GPI 5 In	Last Cue
6	GPI 6 Out		14	GPI 6 In	Recall
7	GPI 7 Out		15	GPI 7 In	
8	Ground				

17. KEY LAYOUT

ST300 KEY CONFIGURATION 2034CL-BVW, 4000CL-BVW V3.0 (&-T, & -PBIO)

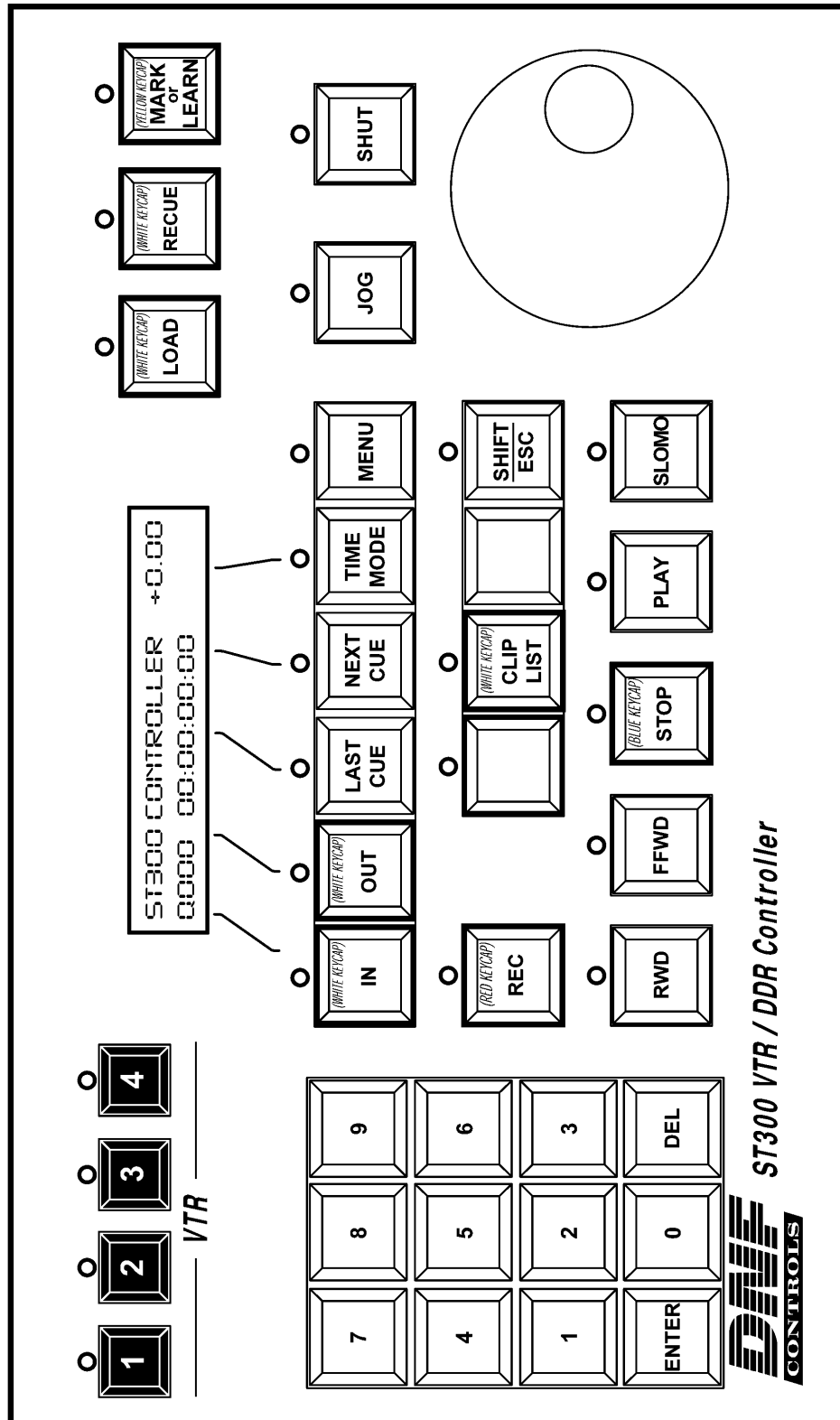

18. DNF CONTROLS LIMITED WARRANTY

DNF Controls warrants its product to be free from defects in material and workmanship for a period of one (1) year from the date of sale to the original purchaser from DNF Controls.

In order to enforce the rights under this warranty, the customer must first contact DNF's Customer Support Department to afford the opportunity of identifying and fixing the problem without sending the unit in for repair. If DNF's Customer Support Department cannot fix the problem, the customer will be issued a Returned Merchandise Authorization number (RMA). The customer will then ship the defective product prepaid to DNF Controls with the RMA number clearly indicated on the customer's shipping document. The merchandise is to be shipped to:

DNF Controls
12843 Foothill Blvd., Suite D
Sylmar, CA 91342
USA

Failure to obtain a proper RMA number prior to returning the product may result in the return not being accepted, or in a charge for the required repair.

DNF Controls, at its option, will repair or replace the defective unit. DNF Controls will return the unit prepaid to the customer. The method of shipment is at the discretion of DNF Controls, principally UPS Ground for shipments within the United States of America. Shipments to international customers will be sent via air. Should a customer require the product to be returned in a more expeditious manner, the return shipment will be billed to their freight account.

This warranty will be considered null and void if accident, misuse, abuse, improper line voltage, fire, water, lightning or other acts of God damaged the product. All repair parts are to be supplied by DNF Controls, either directly or through its authorized dealer network. Similarly, any repair work not performed by either DNF Controls or its authorized dealer may void the warranty.

After the warranty period has expired, DNF Controls offers repair services at prices listed in the DNF Controls Price List. DNF Controls reserves the right to refuse repair of any unit outside the warranty period that is deemed non-repairable.

DNF Controls shall not be liable for direct, indirect, incidental, consequential or other types of damage resulting from the use of the product.

###