



12843 Foothill Blvd.,
Suite D
Sylmar, CA 91342
818 898 3380 voice
818 898 3360 fax
www.dnfcontrols.com

Model No. 2034CL-O-PBIO (& 2034CL-O-T)

300 CLIP INSTANT ACCESS SYSTEM

Odetics Protocol

With Peripheral Bus Interface Option

VERSION 3.1 SOFTWARE

User Manual

TABLE OF CONTENTS

1. REVISION HISTORY	4
<u>GETTING STARTED . . .</u>	<u>5</u>
2. SYSTEM DESCRIPTION	5
DEFINITIONS	5
3. SYSTEM INSTALLATION	6
A. SHOTBOX	6
B. ST300-S/SM, VTR/DDR CONTROLLER	6
C. PRODUCTION SWITCHER	7
4. VIDEO SERVER SETUP	9
5. LOAD A CLIP	9
6. VIEW THE CLIP ID OF THE CURRENTLY LOADED CLIP	10
7. LEARN A CLIP OR CLIP COMBINATION	10
A. LEARN ON THE PRODUCTION SWITCHER	10
B. LEARN ON THE SHOTBOX	10
C. LEARN ON THE ST300	11
8. RECALL A CLIP OR CLIP COMBINATION	12
A. RECALL ON THE PRODUCTION SWITCHER	12
B. RECALL ON THE SHOTBOX	12
C. RECALL ON THE ST300	12
9. RECUE THE CURRENTLY LOADED CLIP	13
10. PLAY CLIP	13
11. LOOP CLIP	13
12. TRIGGER	14
GRASS VALLEY GROUP VALUES	14
SONY VALUES	14
13. SETTING THE IN (OUT) POINTS	15
A. MARKING THE IN (OUT) POINTS	15
B. ENTERING THE IN (OUT) POINTS	15
C. VIEWING THE IN (OUT) POINTS	15
D. CLEARING THE IN (OUT) POINTS	15
14. BVW MODE	15
15. LEARN A CLIP OR CLIP COMBINATION (BVW MODE)	16 16

ADVANCED FEATURES . . . **17**

16. CREATING A CLIP	17
17. CAPTURE FUNCTION	17
A. ENTER PREROLL VALUE	17
B. EXECUTE CAPTURE FUNCTION	18
18. VIEW SHOTBOX SHOTKEY ASSIGNMENTS	18
19. SHOTBOX SHOTKEY MAPS	19
20. SHOTBOX CONTROL SWITCHES	19
21. CLEAR SINGLE CUEPOINT	19
22. TRANSFER CUE LIST	20
A. TRANSMIT CUE LIST FUNCTION	20
B. RECEIVE CUE LIST FUNCTION	21

REFERENCE . . . **22**

23. SETUP MENU	22
24. FUNCTION TABLE	25
25. SPECIFICATIONS	27
A. ST300	27
B. ST420 (SHOTBOX)	28
C. TURNAROUND ADAPTER	29
26. TROUBLESHOOTING	29
ST420 TROUBLESHOOTING	29
27. KEY LAYOUT	30
28. DNF CONTROLS LIMITED WARRANTY	31

Manual Version..... 1.7 101404
Document ID..... 2034CL-O-PBIO_Vs.3.1_User_Manual

1. REVISION HISTORY

122702	Rev. 1.1	Corrected LOOP CLIP section.
050103	Rev. 1.2	Added Parity Setup to PBIO initialization. Corrected Connection Diagram.
070903	Rev. 1.3	Added Play Clip, BVW Mode section. Added Gang and Autorecue setup to Setup Menu section.
110403	Rev. 1.4	Added DNF Controls Limited Warranty. Updated Receive Cue List & Transmit Cue List Function description.
012204	Rev. 1.5	Changed Key Layout.
080304	Rev. 1.6	Added LEARN A CLIP OR CLIP COMBINATION (BVW MODE) section.
101404	Rev. 1.7	Updated Section CREATING A CLIP.

Getting Started . . .

2. SYSTEM DESCRIPTION

The 300 Clip Instant Access System consists of the ST300-SSM VTR Controller, STS420 Shotbox, and Shotlist Software.

The Video Server must support Odetics Broadcast Protocol.

SHOTLIST provides fast access to existing video clips stored on Grass Valley Group PROFILE, Leitch VR or other DDR, VDR, Video Servers supporting Odetics Broadcast Protocol.

The SHOTLIST can contain up to 300 CLIP IDs, stored in non-volatile memory in the ST300.

Remotely view the CLIP IDs that exist in the Video Server under control. Desired clips can be MARKED into the SHOTLIST at a single location or at multiple locations.

Any clip in the SHOTLIST can be quickly loaded by simply entering the associated 3-digit number of its location, then pressing [LOAD]. Press [PLAY] to play the clip. Press [RECUE] to recue to the beginning of the clip or to the “recalled” time if defined.

The PERIPHERAL BUS INTERFACE Option for the ST300 VTR Controller is special software in the ST300. With this Option, the ST300 has 4 Peripheral Device Addresses, one for each VTR that it controls. This allows the production switcher to control any and all VTRs connected to the ST300.

Upon receipt of the Learn command from the production switcher, the ST300 saves the CLIP IDs of the currently loaded clips, the current time of each clip, the VTRs they are loaded on and the current GANG mode into the appropriate Cue Point.

When the Recall command is received, the ST300 loads the “Learned” Clips onto the “Learned” VTRs, cues the Clip to the “Learned” time, then restores the “Learned” GANG mode.

Learn & Recall may also be done directly from the ST300 without the production switcher.

The Trigger function on the production switcher puts the selected VTRs into Play, Stop, Recue or other available modes.

DEFINITIONS

- ❑ Throughout this document VTR, DDR, VDR & Video Server will be referred to collectively as “Video Server.”
- ❑ The ST300-S/SM as the ST300.
- ❑ The ST420 SHOTBOX is referred to as “SHOTBOX.” “SHOTKEY” refers to the 1-30 switches on the SHOTBOX.
- ❑ Words surrounded by brackets, for example, [ENTER], are keys on the ST300 or the SHOTBOX. [XXX] + [XXX] means hold the two keys down simultaneously.

3. SYSTEM INSTALLATION

a. SHOTBOX

- 1) Plug one end of a standard 9-pin, RS422 serial cable, into the OUTPUT connector on the rear of the SHOTBOX. Plug the other end of the cable into the AUX connector on the rear of the ST300.
- 2) Connect the Ault Model #SW300 POWER SUPPLY into the POWER connector on the rear of the SHOTBOX. Plug the Power Supply into an outlet, 90 VAC – 240 VAC.

b. ST300-S/SM, VTR/DDR CONTROLLER

- 1) Plug one end of a 9-conductor, RS422 serial cable into the VTR 1 (2 or 3) connector on the rear of the ST300. Plug the other end of the cable into the REMOTE connector on the Video Server.
- 2) Connect the supplied POWER SUPPLY, APX#4108, into the POWER connector on the rear of the ST300. Plug the Power Supply into an outlet, 90 VAC – 240 VAC.
- 3) Check SETUP MENU prior to using the ST300 to confirm proper Record mode and other User settable modes.
- 4) Select CONTROL MODE = ODETICS.
(See menu description.)

c. PRODUCTION SWITCHER

1) Connect a RS422, 9-pin serial cable to the VTR4 connector on the rear of the ST300, using the supplied Turnaround Adapter. Connect the other end of the cable to the Peripheral Bus Connector on the production switcher.
(Communication Format- 38.4K, 8,1)

2) To select a Production Switcher type (Default = Grass Valley Group).

a) Press [**MENU**] and turn the Wheel until “SWITCHER” is displayed.

b) Press softkeys to select between Sony and GVG.

c) Press [**ESC**] at anytime to exit MENU mode.

3) The ST300 has 4 Peripheral Device Addresses, one for each VTR that it controls.

To set the Device Address for each VTR:

a) Press [**MENU**] and turn the wheel until “Peripheral Address” is displayed.

b) Press VTR[1], VTR[2] or VTR[3] to select a VTR.

c) Assign a Peripheral Device Address for that VTR, from 0 to 23, by entering the desired address using the numeric keypad.

OR

Press [**DEL**] to turn off the device.

d) Select the next VTR and assign a Peripheral Device Address for it.

e) When done, press [**ESC**] to exit MENU mode.

4) Select Parity to match the Parity of the Production Switcher.

a) Press [**MENU**] and turn the wheel until “PARITY” is displayed.

b) Press softkeys to select Odd, Even or None. The Parity must match Production Switcher’s parity.

c) Press [**ESC**] to exit Menu Mode.

5) Enable PBIO.

Press [**PBIO**] key. The LED above the key turns ON when PBIO is enabled. It is OFF when it is disabled.

Installation is complete.

CONNECTION DIAGRAM

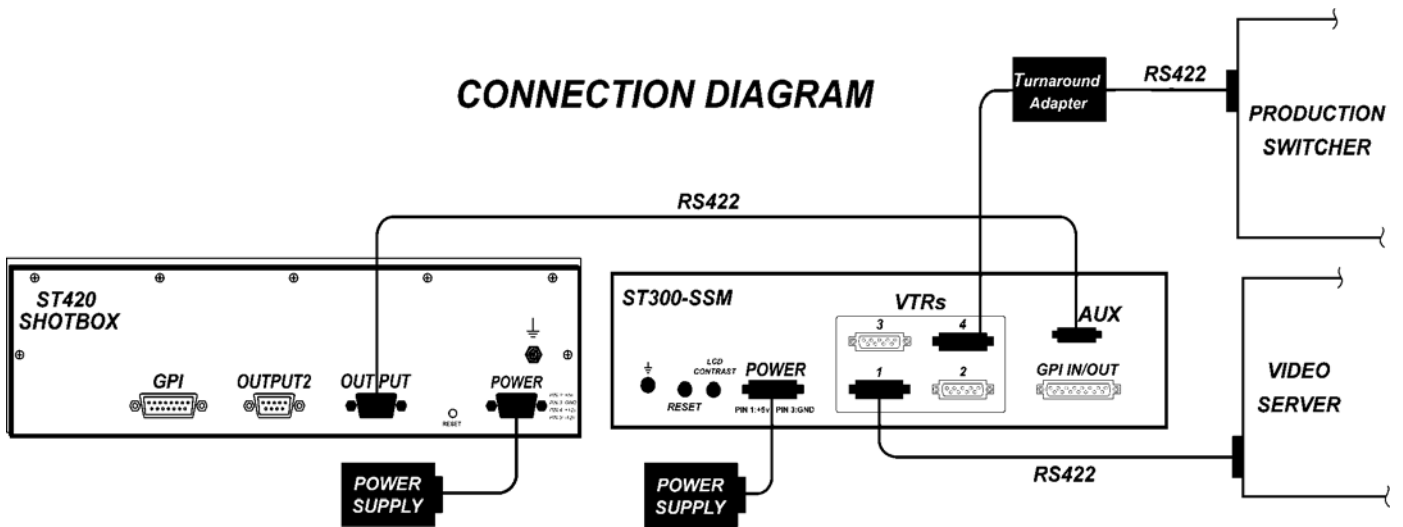

4. VIDEO SERVER SETUP

- a. Select ODETICS Broadcast communications protocol on the VIDEO SERVER to be controlled.
- b. Assign a serial port on the VIDEO SERVER through which the ST300 will control the server.

NOTES: The VIDEO SERVER may not support LTC or VITC time modes in ODETICS Broadcast mode. The ST300 will default to Tape Time if a non-supported time mode is selected on the ST300.

The Grass Valley Group PROFILE does **not** support search to a time location using Timecode (LTC or VITC) in ODETICS Protocol. Tape Time mode (TM) must be selected on the ST300.

In ODETICS Broadcast mode, the VIDEO SERVER may **ONLY** allow Full Record. INSERT and ASSEMBLE record modes may be disabled.

Setup is complete.

5. LOAD A CLIP

Only available in Odetics Control Mode.

- a. Select a VTR by pressing VTR[1], VTR[2], or VTR[3].
- b. Press [**CLIP LIST**] to view the list of CLIP IDs that are resident on the Video Server. The CLIP LIST indicator will turn on.
- c. Press [**LOAD**] to create and load a new clip.
(Creating a clip is described in the CREATING A CLIP section.)
OR

Turn the Wheel to view the existing CLIP IDs on the video server.

Turn the Wheel clockwise to scroll forward, or counter-clockwise to scroll backward, through the list of available CLIPs. Backward scrolling is limited to the last 10 CLIP IDs viewed.

OR

Manually enter a CLIP ID using the ST300 numeric keypad, or PC keyboard (if KBIO option).

OR

Manually enter a Clip ID using the Qwerty keyboard on SHOTBOX.

- d. Press [**LOAD**] to load the selected CLIP ID for playout.
- e. Locate the clip to the desired IN time. Press [**IN**] to mark the IN time.
- f. Locate the clip to the desired OUT time. Press [**OUT**] to mark the OUT time.
- g. Repeat steps a. – f. until clips are loaded into the desired VTRs.
- h. Set the GANG mode, if required.

6. VIEW THE CLIP ID OF THE CURRENTLY LOADED CLIP

Press [**SHIFT**] + [**LOAD**]. The bottom line will show the name of the loaded clip.

7. LEARN A CLIP OR CLIP COMBINATION

a. LEARN ON THE PRODUCTION SWITCHER

- 1) On ST300, Load a clip(s) on the desired VTR(s). (See “**LOAD A CLIP**” section.) (Only for Odetics Control Mode.)
- 2) Select and enable the Peripheral Device Addresses for the ST300.
- 3) Do a LEARN to the desired REGISTER.

The ST300 will: LEARN (save) the VTR number, loaded CLIP ID and current IN and OUT time into the REGISTER number in the ST300.

In BVW mode, the clip ID is not learned.

b. LEARN ON THE SHOTBOX

- 1) Load clip(s) on the desired VTRs. (See “**LOAD A CLIP**” section.) (Only in Odetics Control Mode.)
- 2) Press [**LEARN**]. The LEARN indicator will turn on.
- 3) Select the desired BANK and ShotKey.
- 4) Press [**LEARN**] to exit at anytime.
NOTE: The [**LEARN**] key toggles LEARN mode on/off.

The controller will: LEARN (save) the VTR Number (1,2,3), loaded CLIP ID and current IN and OUT time to the selected Cue Point.

In BVW mode, the clip ID is not learned.

c. LEARN ON THE ST300

- 1) Load a clip(s) on the desired VTR(s). (See “**LOAD A CLIP**” section.)
(Only in Odetics Control Mode.)
- 2) Select the desired Cue Point by pressing [**NEXT CUE**], [**LAST CUE**] or by manually entering the Cue Point using the numeric keypad.

The selected Cue Point number is shown on the bottom line of the display.

- 3) Press [**SHIFT**] + [**MARK**] to start the LEARN.
The first line of the display will show “Select VTRs:”
The second line of the display will show “Mark-Lrn, ESC-cancel.”
- 4) Press VTR[**1**], VTR[**2**] or VTR[**3**] to select the VTR to be learned into the current Cue Point.

If the VTRs are ganged, select one VTR that is part of the Gang. The rest of the Gang will learn automatically.

- 5) Press [**MARK**] to complete the LEARN.
OR

Press [**ESC**] to exit without LEARNING.

The ST300 will: LEARN (save) the VTR Number (1,2,3), loaded CLIP ID and current IN & OUT time to the selected Cue Point.

In BVW mode, the Clip ID is not learned.

8. RECALL A CLIP OR CLIP COMBINATION

a. RECALL ON THE PRODUCTION SWITCHER

RECALL the desired REGISTER NUMBER.

The ST300 will automatically load the Learned clips on the Learned VTRs, cue the clips to the Learned time, then set the Learned GANG mode.

In BVW mode, Clips are not loaded, the video is positioned to learned IN point.

b. RECALL ON THE SHOTBOX

- 1) Select the desired Bank.
- 2) Press the desired shotkey.

The ST300 will automatically load the learned clips on the learned VTRs, cue the clips to the Learned time, then set the Learned Gang Mode.

In BVW mode, Clips are not loaded, the video is positioned to learned IN point.

c. RECALL ON THE ST300

- 1) Select the desired Cue Point by pressing [**NEXT CUE**], [**LAST CUE**] or by manually entering the Cue Point using the numeric keypad.

The selected Cue Point number is shown on the bottom line of the display.

- 2) Press [**LOAD**] on the ST300.

The ST300 will automatically load the Learned clips on the Learned VTRs, cue the clips to the Learned time, then set the Learned GANG mode. If **RECALL MODE** in the Setup Menu is set to **REDIR**, and a cue point contains only one clip, then the clip will be **REDIRECTED** to load on the currently selected VTR, not the Learned VTR.

In BVW mode, Clips are not loaded, the video is positioned to learned IN point.

9. RECUE THE CURRENTLY LOADED CLIP

Press **[RECUE]**. If an IN Point is marked (the IN indicator is on), the clip will RECUE to the IN Point.

If the IN point is not marked, the clip will RECUE to the start of the clip.

OR

Press **[SHIFT] + [RECUE]**.

a. Enter the desired time to search to using the ST300's numeric keypad.

b. Press **[ENTER]** to search to the entered time.

OR

Press **[ESC]** to exit without searching.

10. PLAY CLIP

a. Load a clip from Cliplist or Recall a learned clip.

b. Mark IN (OUT) points if desired. (See Section 13, “**SETTING THE IN (OUT) POINTS.**”)

c. Press **[PLAY]**.

The clip will play from the current point to the OUT point or, if no OUT point is marked, to the end of the clip.

If Autorecue Option is ON (see Setup Menu), the clip will recue to the IN point (or the beginning of the clip) once the OUT point (or the end of the clip) is reached.

11. LOOP CLIP

Only available in Odetics Control Mode.

a. **LOAD** a clip from **CLIPLIST** or **RECALL** a learned clip.

b. Press **[LOOP ENABLE]** to a loaded clip. The **LOOP ENABLE** indicator will turn on. The second line of the display will show “Looping clip . . .”

c. Press **[STOP]** to stop the loop play.

If the clip ID ends with an asterisk (“*”), it will automatically loop when either **[LOOP ENABLE]** or **[PLAY]** is pressed.

12. TRIGGER

The operator fires a trigger using either the Timeline or Run function on the production switcher. The ST300 puts the Video Server into the following modes based upon the trigger value:

GRASS VALLEY GROUP VALUES

<u>Trigger Value</u>	<u>Mode</u>
0	Play
1	Recue to beginning of clip
2	Slo-mo using ST300 Wheel Preset or T-Bar Speed
3	Reverse Play
4	Still Frame
5	Loop
6	Record
7 or greater	Play

SONY VALUES

<u>Trigger Value</u>	<u>Mode</u>
0	Recue to beginning of clip
1	Play
2	Slo-mo using ST300 Wheel Preset or T-Bar Speed
3	Reverse Play
4	Still Frame
5	Loop
6	Record
7 or greater	Play

To control more than one VTR, enable the Peripheral Device Address for the required VTRs. The Trigger will be sent to the enabled devices.

OR

GANG the required VTRs on the ST300. Refer to the Function Table for GANG instructions. Enable the Peripheral Device Address for one of the GANGed VTRs. The Trigger will be sent to the enabled VTR. The other VTRs in the GANG will perform the same action.

13. SETTING THE IN (OUT) POINTS

a. MARKING THE IN (OUT) POINTS

- 1) Locate the clip to the desired IN (OUT) time.
- 2) Press **[IN]** (**[OUT]**) to set the IN (OUT) Point. The IN (OUT) indicator will turn on.
The display will show “IN (OUT) xx:xx:xx:xx” where xx:xx:xx:xx is the saved time.

b. ENTERING THE IN (OUT) POINTS

- 1) Press **[SHIFT]** + **[IN]** (**[OUT]**) to manually enter a new IN (OUT) time.
- 2) Press **[ENTER]** to save the entered time or press **[ESC]** to exit without saving.
OR
Press **[RECUE]** to search to viewed point.

c. VIEWING THE IN (OUT) POINTS

When the IN (OUT) indicator is on,
press **[IN]** (**[OUT]**) to view the existing IN (OUT) Point.

d. CLEARING THE IN (OUT) POINTS

Press and hold **[DEL]**, then press and release **[IN]** (**[OUT]**).
The IN (OUT) indicator goes off.

14. BVW MODE

If you wish to control a tape machine or a DDR with the 2034CL-O system, select control MODE=BVW (see Setup Menu section). In this mode, the media is accessed by timecode, not by clip names. The cuepoints in BVW mode consist only of IN point, OUT point and Gang information.

The following functions are not available in BVW mode:

- View Clip ID
- Recue Clip
- Loop Clip
- Capture
- Create Clip

All other functions work as described in the manual.

15. LEARN A CLIP OR CLIP COMBINATION (BVW MODE)

- a. Select the desired Cue Point by pressing [NEXT CUE], [LAST CUE], or by manually entering the Cue Point using the numeric keypad.

The selected Cue Point number is shown on the bottom line of the display.

- b. Locate the clip to the desired IN time. Press [IN] to mark the IN time.
- c. Locate the clip to the desired OUT time. Press [OUT] to mark the OUT time.

- d. Press [SHIFT] + [MARK] to start the LEARN.
The first line of the display will show "Select VTRs:"
The second line of the display will show "Mark-Lrn, ESC-cancel."

- e. Press VTR[1], VTR[2], VTR[3] or VTR[4] to select the VTR to be learned into the current Cue Point.

If the VTRs are ganged, select one VTR that is part of the Gang. The rest of the Gang will learn automatically.

- f. Press [MARK] to complete the LEARN.
OR

Press [ESC] to exit without LEARNING.

The ST300 will: LEARN (save) the VTR number (1,2,3,4) and current IN & OUT time to the selected Cue Point.

Advanced Features . . .

16. CREATING A CLIP

Only available in Odetics Control Mode.

- a. Press [**CLIP LIST**]. The display will show “CREATE NEW CLIP.”
- b. Press [**LOAD**]. The display will show the default CLIP ID.
- c. Press [**ENTER**] to accept the default CLIP ID.
OR

Enter an ID with a maximum of 8 characters using the SHOTBOX’s Qwerty.

NOTE: For numbers on the SHOTBOX keyboard, use bank keys 0-9.
OR

Enter a numeric ID with a maximum of 8 characters using the ST300’s numeric keypad.

- d. Press [**ENTER**] on the ST300 to create the selected CLIP ID.
- e. If the selected CLIP ID already exists, a warning message will be displayed. To load the existing clip, press [**ENTER**]. Press [**ESC**] to exit without loading the existing clip.

17. CAPTURE FUNCTION

Only available in Odetics Control Mode.

The CAPTURE function allows source material from a VTR to be easily and quickly recorded into the VIDEO SERVER. A CLIP ID is also created.

VTR1 is always the Recorder (the VIDEO SERVER).

Select VTR[2] or VTR[3] as the source VTR. Any RS422, SONY protocol compatible VTR can be used.

Use the transport function keys to control the source VTR. Each source VTR has its own set of IN and OUT points.

a. ENTER PREROLL VALUE

- 1) Press [**MENU**] and turn the Wheel to “Enter PREROLL:”
- 2) Enter the desired preroll value using the ST300’s numeric keypad.
- 3) Press [**ENTER**] to save the entered value.
OR

Press [**ESC**] to exit without saving.

b. EXECUTE CAPTURE FUNCTION

- 1) Press VTR[2] or VTR[3] to select the source VTR.
- 2) Set IN and OUT points as described in “SETTING THE IN (OUT) POINTS” section on the source VTR.
- 3) Press [SHIFT] + [RECORD]. The display will prompt you for a CLIP ID. A default CLIP ID will be shown.
- 4) Press [LOAD] to accept the default CLIP ID.

OR

Enter a name with a maximum of 8 characters using the SHOTBOX Qwerty keyboard.

OR

Use [NEXT CUE], [LAST CUE] and Wheel to edit the CLIP ID. Use the [NEXT CUE] and [LAST CUE] keys to position the cursor. Turn the Wheel to select the desired letter.

OR

Manually enter a numeric ID using the numeric keypad.

Press [LOAD] to accept the CLIP ID. The ST300 will create the new CLIP ID on the Video Server.

The Source VTR will preroll to the IN Point, then play. At the source VTR’s IN point, the RECORDER will go into record.

At the Source VTR’s OUT point, the RECORDER will terminate record, post-roll for 2 seconds, then stop.

The Source VTR will search to the OUT point and stop. The OUT point will be cleared. The IN indicator will stay on. The OUT indicator will turn off.

18. VIEW SHOTBOX SHOTKEY ASSIGNMENTS

- a. Press and hold [VIEW]. The VIEW indicator comes on.
- b. Press and hold the desired shotkey.
- c. The switch turns RED and the content (CLIP ID) is displayed on a virtual display.

For Example:

VTR 1 Clip 23	VTR 2 Clip 13	VTR 3 Clip 77	VTR 4 No Assignment
------------------	------------------	------------------	------------------------

NOTE: All the remaining switches are not illuminated.

- d. Release the keys to return to normal operation.

19. SHOTBOX SHOTKEY MAPS

The SWITCHES on the SHOTBOX access the SHOTLIST locations as follows:

BANK 0, SWITCHES 1 → 30 access Cue Points 001 → 030 and e-mem registers 1 - 30.
BANK 1, SWITCHES 1 → 30 access Cue Points 101 → 130 and e-mem registers 31 - 60.
BANK 2, SWITCHES 1 → 30 access Cue Points 201 → 230 and e-mem registers 61 - 90.
BANK 3, SWITCHES 1 → 09 access Cue Points 301 → 309 and e-mem registers 91 - 99.
MARK 3, SWITCHES 10 → 30 access Cue Points 310 - 330
BANK 4, SWITCHES 1 → 50 access Cue Points 401 → 430.
BANK 5, SWITCHES 1 → 30 access Cue Points 501 → 530.
BANK 6, SWITCHES 1 → 30 access Cue Points 601 → 630.
BANK 7, SWITCHES 1 → 30 access Cue Points 701 → 730.
BANK 8, SWITCHES 1 → 30 access Cue Points 801 → 830.
BANK 9, SWITCHES 1 → 30 access Cue Points 901 → 930.

20. SHOTBOX CONTROL SWITCHES

- a. **[PLAY]**: Plays out the selected clip.
- b. **[RECUE]**: Returns to the beginning of the clip.
- d. **[STOP]**: Stops playout of the clip.
- e. **[SHIFT] + [SHOTKEY]**: Clears the contents of the pressed shotkey.

21. CLEAR SINGLE CUEPOINT

On the Shotbox, press **[SHIFT]** + the Shotkey, the content of which you wish to clear. The Shotkey becomes blank, the corresponding cuepoint is cleared.

22. TRANSFER CUE LIST

a. TRANSMIT CUE LIST FUNCTION

The TRANSMIT CUE LIST function allows you to transmit your list of Cue Points to a PC, using the provided utility software on the PC, or to another ST300. Transfer to a PC requires OpSuite 3.0 software, which runs on a Windows-based computer. Contact DNF Controls for more information.

1) To Transmit Cue Points to Another ST300:

- a) Connect the VTR4 connector on the rear of the ST300 to the VTR4 connector of the receiving ST300 using an RS422 9-pin cable with TX and RX lines crossed. (A “turnaround” cable.)
- b) Press [MENU].
- c) Scroll the Wheel until “Transmit CUE list? YES=Enter, Exit=ESC” is displayed.
- d) Press [ENTER] to start transmitting. The Display shows “Waiting to transmit” on the first line.
- e) When the Receiver is ready, transfer starts automatically. The Display now shows “Transmitting cuelist.”
- f) After the transfer is over, the display shows “Transfer is over” for one second and then shows “Waiting to transmit” again.
- g) Connect another ST300 to transmit the list again.

OR

Press [ESC] twice to exit the MENU mode.

2) To Transmit Cue Points to a PC:

- a) Connect the VTR4 connector on the back of the ST300 to one of the COM ports on the PC using a RS422 to RS232 adapter.
- b) Repeat steps b) thru g) of “To Transmit Cue Points to Another ST300” section.

b. RECEIVE CUE LIST FUNCTION

The RECEIVE CUELIST function allows you to receive a list of Cue Points from a PC or from another ST300. Transfer to a PC requires OpSuite 3.0 software, which runs on a Windows-based computer. Contact DNF Controls for more information.

1) To Receive Cue Points From Another ST300

- a) Connect the VTR4 connector on the back of the ST300 from the VTR4 connector of the transmitting ST300 using RS422 9-pin cable with TX and RX lines crossed.
(A “Turnaround” Cable)
- b) Press [**MENU**].
- c) Scroll the Wheel until “Receive CUE List? YES=Enter, Exit=ESC” is displayed.
- d) Press [**ENTER**] to start receiving.
The Display shows “Waiting to receive” on the first line.
- e) When the Transmitter is ready, transfer starts automatically.
The Display now shows “Receiving cuelist.”
- f) After the transfer is over the display shows “Done-Success! Press any key...”
- g) Press any key. The display shows “Receive cuelist?” message.
- h) Press [**ESC**] to exit the MENU mode.

2) To Receive Cue Points From the PC

- a) Connect the VTR4 connector on the back of the ST300 to one of the COM ports on the PC using RS422 to RS232 adapter.
- b) Repeat steps b) – h) of “**To Receive Cue Points From Another ST300**” section.

Reference . . .

23. SETUP MENU

Press [MENU]. The MENU indicator will turn on.

Turn the Wheel to select item to change.

Press [MENU] **OR** use the Softkeys to change the desired mode for that option.

Turn the Wheel at anytime to select another item.

Press [ESC] at anytime to exit SETUP MENU. The MENU indicator will turn off.

<u>MENU MODES</u>	<u>(Turning Wheel Clockwise)</u>										
RECORD	Press Softkey to select the desired record mode: Assemble, Insert, Lockout or Crash (Full).										
WIND MODE	Press Softkey to select: HOLD (fast wind is maintained only while key is depressed). OR LATCH (fast wind is initiated and maintained with momentary key press). Select fast wind speed (03.9X, etc.) by pressing Softkey.										
SLOMO	<div style="display: flex; justify-content: space-between;"> <div style="width: 45%;"> <p>ST300 display shows (Non T-Bar version):</p> </div> <div style="width: 50%; border: 1px solid black; padding: 5px;"> <table style="width: 100%; border-collapse: collapse;"> <tr> <td style="width: 60%;">SLOMO with:</td> <td style="width: 40%;">WHEEL</td> </tr> <tr> <td>SpdRange</td> <td>Preset</td> </tr> </table> </div> </div> <div style="display: flex; justify-content: space-between; margin-top: 10px;"> <div style="width: 45%;"> <p>ST300 display shows (T-Bar version):</p> </div> <div style="width: 50%; border: 1px solid black; padding: 5px;"> <table style="width: 100%; border-collapse: collapse;"> <tr> <td style="width: 60%;">SLOMO with:</td> <td style="width: 40%;">TBAR</td> </tr> <tr> <td>Wheel</td> <td>SpdRange</td> </tr> <tr> <td></td> <td>Preset</td> </tr> </table> </div> </div> <p>Press Softkey [TBAR] (or [WHEEL]) to toggle between T-BAR and WHEEL.</p> <p>NOTE - The T-BAR has a fixed speed range of 0 → +200 with a detent at +100% play speed.</p> <p>For Wheel only: Press Softkey [SPDRANGE] to select SLOMO speed ranges:</p> <p>Press Softkey to select 0 → +200 OR -100 → +200. Press Softkey [BACK] to return to SLOMO MENU.</p> <p>Press [ESC] to exit SETUP MENU. OR turn the Wheel to select another item.</p> <p>(Continued on next page.)</p>	SLOMO with:	WHEEL	SpdRange	Preset	SLOMO with:	TBAR	Wheel	SpdRange		Preset
SLOMO with:	WHEEL										
SpdRange	Preset										
SLOMO with:	TBAR										
Wheel	SpdRange										
	Preset										

	<p>For Wheel only: Press Softkey [PRSET] to select the SLOMO Preset Speed Mode.</p> <p>Press Softkey [UPDATE]. When exiting SLOMO mode, the last used speed is saved in the Preset Speed register.</p> <p>OR Press Softkey [STATIC]. The Preset Speed register is NOT updated when exiting SLOMO mode. It is only changed by [SHIFT] + [SLOMO] (PRESET SLOMO).</p>
GANG MODE	<p>Press Softkey to select PERMANENT GANG (described in the FUNCTION Table) or TEMPORARY GANG.</p> <p>In TEMPORARY mode, press and hold the VTR key that you want to read status from, then press the VTR#s of those VTRs that you want to include in the gang. Release the keys. The LED on the monitored VTR blinks, all other VTRs in the gang stay on constantly. To break the temporary gang, press any VTR# key.</p>
ST300 SETUP	<div style="border: 1px solid black; padding: 10px; margin: 10px auto; width: fit-content;"> <p style="text-align: center;">ST300 SETUP</p> <p style="text-align: center;">Clear Cues SetDefault</p> </div> <p>Press Softkey beneath ClearCues to clear all Cue Points to 00:00:00:00. Press Softkey [YES] when asked “Are You Sure?”</p> <p>Press Softkey beneath SetDefault to set ST300 to default settings. Press Softkey [YES] when asked “Are You Sure?”</p> <p>IMPORTANT NOTE: Please set these items during initial installation.</p>
DISPLAY SOFTWARE VERSION	<p>The version number and date for the currently installed software is displayed. For example:</p> <div style="border: 1px solid black; padding: 10px; margin: 10px auto; width: fit-content;"> <p style="text-align: center;">2034CL-O V3.1</p> <p style="text-align: center;">072400</p> </div>
SYNC	<p>Set to ON if black burst is supplied to the Ref Video connector on the rear panel. Set to OFF if no blackburst is supplied.</p>
AUTO RECUE	<p>If Set to [ON] the video automatically recues back to the IN point (or to the beginning of the clip if there is no IN point) after the playout reaches OUT point (or the end of the clip).</p>
RECORD	<p>Press Softkey to select single button or 2-button record. RECORD = [REC] Only.</p> <p>OR [REC] + [PLAY].</p>
RECALL MODE	<p>Press [NORMAL] or [REDIR] (redirect).</p> <p>NORMAL - The cue point will load on the learned VTR.</p> <p>REDIR - When one and only one clip is learned into a Cue Point, the Clip will be REDIRECTED to load on the currently selected VTR.</p>

PBIO ADDRESS	<p>Press VTR key to select the VTR to which to assign a PBIO address. Display shows:</p> <div style="border: 1px solid black; padding: 5px; width: fit-content; margin: 10px auto;"> <p>PBIO Address = 00</p> <p>Enter 00-23</p> </div> <p>Enter address number desired on numeric keypad. Repeat for all VTRs assigned.</p>
SWITCHER TYPE	<p>Select your switcher type. GVG = Grass Valley Group (default) or Sony. For Philips DD35 with PBus, use GVG.</p>
PARITY	<p>Select Parity type Switcher is putting out on the PBUS: ODD, EVEN or NONE</p>
ENTER PREROLL	<p>Enter the desired preroll value using the ST300's numeric keypad. Turn wheel to save the entered value OR press [ESC] to exit without saving.</p>
RECORD DELAY	<p>Enter up to 99 frames record delay (used in Capture Function). Typical value is 3 frames.</p>
CONTROL MODE SELECT	<p>Select Control mode Odetics\BVW. Have Odetics selected for video server control and clip access. Have BVW selected to access media by timecode.</p>
TRANSMIT CUELIST	<p>Transmit Cuelist to another ST300 or to a PC. See Section: "Transfer Cue List."</p>
RECEIVE CUELIST	<p>Receive Cuelist from another ST300 or a PC. See Section: "Transfer Cue List."</p>

24. FUNCTION TABLE

FUNCTION	KEY PRESS	DESCRIPTION
GOTO ENTERED TIME	[SHIFT] + [RECUE]	Search the VTR to the manually entered time. Use the ST300 numeric keypad. To manually enter the desired time press [ENTER] or [RECUE]. NOTE: GRASS VALLEY GROUP Profile does not support TC or VITC time search.
GANG	[SHIFT]+[VTR #1] OR [SHIFT]+[VTR #2] OR [SHIFT]+[VTR #3]	Individually press the VTR keys to be included in the gang; the LED above the key will turn on. Press the VTR key again to remove from gang; the LED above the key will turn off. Press [ESC] to exit. The VTR LEDs that are on show the gang. The flashing LED shows which VTR is currently selected.
FFWD	[FFWD]	Press and HOLD to FFWD. Release key to stop. Set WIND Speed in MENU.
JOG	[JOG]	Select JOG mode and enable Wheel.
LAST CUE	[LAST CUE]	Step to the previous Cue Point Location.
NEXT CUE	[NEXT CUE]	Step to the next Cue Point Location.
RECORD	[REC]	Places VTR into the Record mode selected by RECORD MODE in the SETUP MENU. Press [RECORD] or [RECORD] + [PLAY].
REWIND	[RWD]	Press and HOLD to REWIND. Release key to stop. Set WIND Speed in MENU.
SHUTTLE	[SHUTTLE]	Select SHUTTLE mode and enable Wheel.
SLOMO	[SLOMO]	Press [SLOMO] to slo-mo the VTR. Turn the Wheel (or move the T-Bar, if available) to change the play speed. Press [SLOMO] to STILL frame OR press any transport key to exit SLOMO.
SLO-MO SPEED PRESET	[SHIFT] + [SLOMO]	For WHEEL ONLY : Press [SHIFT] + [SLOMO] to preset the slo-mo speed. Turn the Wheel to select desired speed. Press [ESC] or any transport key to exit.
STOP	[STOP]	Press once to STILL frame VTR. Press again to put VTR into STOP mode.
TIME MODE SELECT	[TIME MODE]	Press to toggle between Timecode (TC), VITC (VT) or Tape Timer (TM) display modes.
LOOP CLIP	[LOOP ENABLE]	Press to loop a whole clip or a part between IN and OUT points (if marked).

PBIO ENABLE/ DISABLE	[PBIO]	Toggle the key to enable/disable PBus commands. If the LED is on, PBIO is enabled. If the LED is OFF, PBIO is disabled.
PLAY	[PLAY]	Plays the clip. If the OUT point is set, stops at the OUT point. If no OUT point is set, plays to the end of the clip. If the clip ends with “*”, loops the clip.
PLAY TO THE END OF THE CLIP	[SHIFT] + [PLAY]	Plays to the end of the clip. Disregards the OUT point and the “*”.
ALIGN GANGED CHANNELS	[SHIFT] + [STOP]	Re-establishes the initial offset between ganged channels.

25. SPECIFICATIONS

a. ST300

Power:	90 VAC to 265 VAC adapter supplied with IEC connector
Size:	(L" x W" x H") 12" x 6" x 1.5" (front) 3.0" (rear) (T-Bar unit is 12.6" wide)
Weight:	4 lbs.
Rear Panel Connectors:	VTR1, VTR2, VTR3, VTR4 (All DB9F) GPI (DBF15F) Power (DB9M) Aux (DB9F) Reference Video (BNC)
Display:	Easy to read 2-line, back-lit LCD display (User adjustable contrast)
Jog/Shuttle Wheel:	With mechanical detents.
Optional "T"-bar:	Slo-mo 0-200% of Play Speed

VTR RS422 SERIAL CONNECTOR

9-Pin D-Type, Female

Pin #	1	Frame Ground	6	Receive Common
	2	Receive A ←	7	Receive B ←
	3	Transmit B →	8	Transmit A →
	4	Transmit Common	9	Frame Ground
	5	Spare		

POWER CONNECTOR

9-Pin D-Type, Male

Pin #	1	+5v DC	6	+5 VDC
	2	+5v DC	7	Ground
	3	Ground	8	Ground
	4	+12 VDC	9	Ground
	5	-12 VDC		

AUX PORT RS422 SERIAL CONNECTOR

9-Pin D-Type, Female

Pin #	1	Frame Ground	6	Receive Common
	2	Receive A ←	7	Receive B ←
	3	Transmit B →	8	Transmit A →
	4	Receive Common	9	Frame Ground
	5	Spare		

GPI IN/OUT CONNECTOR 15-Pin D-Type, Female (DB15F)

Pin #	Description	Function	Pin #	Description	Function
1	GPI 1 Out		9	GPI 1 In	Play
2	GPI 2 Out		10	GPI 2 In	Stop
3	GPI 3 Out		11	GPI 3 In	Recue
4	GPI 4 Out		12	GPI 4 In	Next Cue
5	GPI 5 Out		13	GPI 5 In	Last Cue
6	GPI 6 Out		14	GPI 6 In	Recall
7	GPI 7 Out		15	GPI 7 In	
8	Ground				

b. ST420 (SHOTBOX)

Power: +5v DC @ 4A, +12v DC @ 1.0A, -12v DC @ 0.6A
90 VAC to 265 VAC adapter supplied with IEC connector

Size: [L" x W" x H"] 11.5" x 6.5" x 1.75" (front) 3.5" (rear)

Weight: 4 lbs.

Rear Panel Connectors: Power: DB9M
OUTPUT: ... DB9F

RS422 SERIAL CONNECTOR 9-Pin D-Type, Female

Pin #	1	Frame Ground	6	Transmit Common
	2	Transmit A →	7	Transmit B →
	3	Receive B ←	8	Receive A ←
	4	Receive Common	9	Frame Ground
	5	Spare		

POWER CONNECTOR 9-Pin D-Type, Male

Pin #	1	+5v DC	6	+5 VDC
	2	+5v DC	7	Ground
	3	Ground	8	Ground
	4	+12 VDC	9	Ground
	5	-12 VDC		

c. **TURNAROUND ADAPTER**

Convert CONTROLLER PORT 9-Pin D-Type, Female	➔	DEVICE PORT 9-Pin D-Type, Male
1 Frame Ground		1 Frame Ground
2 Receive A ←		2 Transmit A →
3 Transmit B →		3 Receive B ←
4 Transmit Common		4 Transmit Common
5 No Connection		5 No Connection
6 Receive Common		6 Receive Common
7 Receive B ←		7 Transmit B →
8 Transmit A →		8 Receive A ←
9 Frame Ground		9 Frame Ground

26. TROUBLESHOOTING

ST420 TROUBLESHOOTING

- All keys are RED - no communication with ST300.
- All keys are dark - no communication between the ST300 and the Video Server.
- The version of the ST420 must comply in the software version with the ST300 it is connected to.

To determine the software version of the ST420 do the following:

- Press **[SHIFT] + [STOP] + [PLAY]**.
The key that displays the current version is RED.
- The ST420 displays:
“SELECT ST300 **[V2.1 or V2.0]** or **[V3.0 or V4.0]**.”

Press **[V3.0 or V4.0]** key for proper Shotbox setup.

27. KEY LAYOUT

ST300 KEY CONFIGURATION / **2034CL-O & 4000CL-O V3.1 (& -T, & -PBIO)**

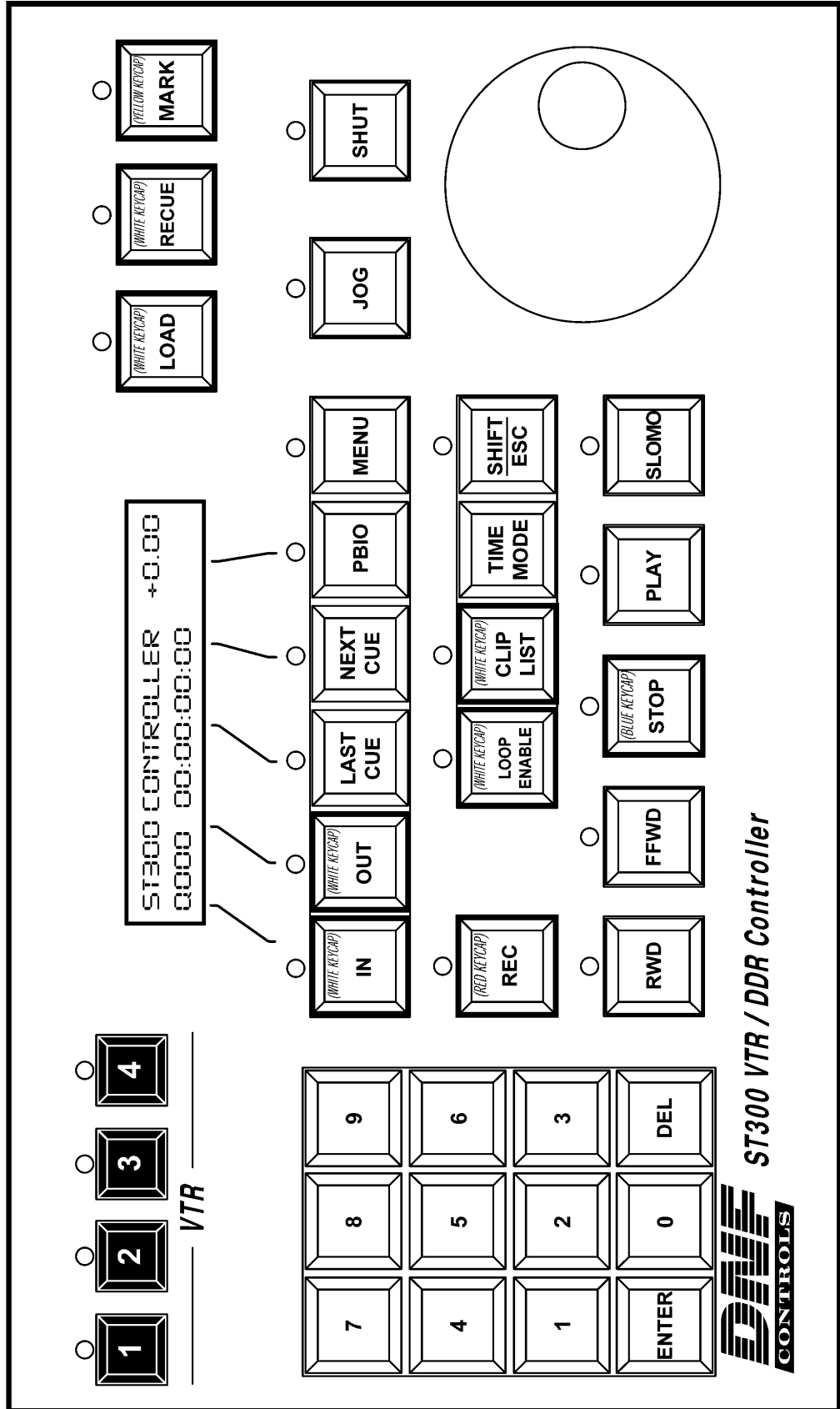

28. DNF CONTROLS LIMITED WARRANTY

DNF Controls warrants its product to be free from defects in material and workmanship for a period of one (1) year from the date of sale to the original purchaser from DNF Controls.

In order to enforce the rights under this warranty, the customer must first contact DNF's Customer Support Department to afford the opportunity of identifying and fixing the problem without sending the unit in for repair. If DNF's Customer Support Department cannot fix the problem, the customer will be issued a Returned Merchandise Authorization number (RMA). The customer will then ship the defective product prepaid to DNF Controls with the RMA number clearly indicated on the customer's shipping document. The merchandise is to be shipped to:

DNF Controls
12843 Foothill Blvd., Suite D
Sylmar, CA 91342
USA

Failure to obtain a proper RMA number prior to returning the product may result in the return not being accepted, or in a charge for the required repair.

DNF Controls, at its option, will repair or replace the defective unit. DNF Controls will return the unit prepaid to the customer. The method of shipment is at the discretion of DNF Controls, principally UPS Ground for shipments within the United States of America. Shipments to international customers will be sent via air. Should a customer require the product to be returned in a more expeditious manner, the return shipment will be billed to their freight account.

This warranty will be considered null and void if accident, misuse, abuse, improper line voltage, fire, water, lightning or other acts of God damaged the product. All repair parts are to be supplied by DNF Controls, either directly or through its authorized dealer network. Similarly, any repair work not performed by either DNF Controls or its authorized dealer may void the warranty.

After the warranty period has expired, DNF Controls offers repair services at prices listed in the DNF Controls Price List. DNF Controls reserves the right to refuse repair of any unit outside the warranty period that is deemed non-repairable.

DNF Controls shall not be liable for direct, indirect, incidental, consequential or other types of damage resulting from the use of the product.

###