



12843 Foothill Blvd.,
Suite D
Sylmar, CA 91342
818 898 3380 voice
818 898 3360 fax
www.dnfcontrols.com

Model No. 2034CL-O-KBIO (& 2034CL-O-T)

300 CLIP INSTANT ACCESS SYSTEM

Odetics Protocol

**With
Keyboard Interface Option**

VERSION 3.1 SOFTWARE

NOTE: Supports up to 3 Video Server Channels

User Manual

TABLE OF CONTENTS

1. REVISION HISTORY	4
<u>GETTING STARTED . . .</u>	<u>5</u>
2. SYSTEM DESCRIPTION	5
DEFINITIONS	5
3. SYSTEM INSTALLATION	6
A. SHOTBOX	6
B. ST300-S/SM, VTR/DDR CONTROLLER	6
4. VIDEO SERVER SETUP	8
5. LOAD A CLIP	8
6. VIEW THE CLIP ID OF THE CURRENTLY LOADED CLIP	9
7. LEARN A CLIP OR CLIP COMBINATION	9
A. LEARN ON THE SHOTBOX	9
B. LEARN ON THE ST300	9
8. RECALL A CLIP OR CLIP COMBINATION	10
A. RECALL ON THE SHOTBOX	10
B. RECALL ON THE ST300	10
9. RECUE THE CURRENTLY LOADED CLIP	10
10. PLAY CLIP	11
11. LOOP CLIP	11
12. SETTING THE IN (OUT) POINTS	12
A. MARKING THE IN (OUT) POINT	12
B. ENTERING THE IN (OUT) POINTS	12
C. VIEWING THE IN (OUT) POINTS	12
D. CLEARING THE IN (OUT) POINT	12
13. BVW MODE	12
14. LEARN A CLIP OR CLIP COMBINATION (BVW MODE)	13

ADVANCED FEATURES . . . **14**

15. CREATING A CLIP	14
16. CAPTURE FUNCTION	14
A. ENTER PREROLL VALUE	14
B. EXECUTE CAPTURE FUNCTION	15
17. VIEW SHOTBOX SHOTKEY ASSIGNMENTS	15
18. SHOTBOX SHOTKEY MAPS	16
19. SHOTBOX CONTROL SWITCHES	16
20. CLEAR SINGLE CUEPOINT	16
21. TRANSFER CUE LIST	17
A. TRANSMIT CUE LIST FUNCTION	17
B. RECEIVE CUE LIST FUNCTION	18

REFERENCE . . . **19**

22. SETUP MENU	19
23. FUNCTION TABLE	22
24. SPECIFICATIONS	24
A. ST300	24
B. ST420 (SHOTBOX)	25
25. TROUBLESHOOTING	26
ST420 TROUBLESHOOTING	26
26. KEY LAYOUT	27
27. DNF CONTROLS LIMITED WARRANTY	28

Manual Version..... 1.3 080304
Document ID..... 2034CL-O-KBIO_Vs.3.1_User_Manual

1. REVISION HISTORY

- | | | |
|--------|-----|--|
| 081803 | 1.0 | Original document. |
| 110403 | 1.1 | Added DNF Controls Limited Warranty.
Updated Receive Cue List & Transmit Cue List Function description. |
| 012204 | 1.2 | Changed Key Layout. |
| 080304 | 1.3 | Added LEARN A CLIP OR CLIP COMBINATION (BVW MODE) section. |

Getting Started . . .

2. SYSTEM DESCRIPTION

The 300 Clip Instant Access System consists of the ST300-SSM VTR Controller, STS420 Shotbox, and Shotlist Software.

The Video Server must support Odetics Broadcast Protocol.

SHOTLIST provides fast access to existing video clips stored on Grass Valley Group PROFILE, Leitch VR or other DDR, VDR, Video Servers supporting Odetics Broadcast Protocol.

The SHOTLIST can contain up to 300 CLIP IDs, stored in non-volatile memory in the ST300.

Remotely view the CLIP IDs that exist in the Video Server under control. Desired clips can be MARKED into the SHOTLIST at a single location or at multiple locations.

Any clip in the SHOTLIST can be quickly loaded by simply entering the associated 3-digit number of its location, then pressing [LOAD]. Press [PLAY] to play the clip. Press [RECUE] to recue to the beginning of the clip or to the “recalled” time if defined.

DEFINITIONS

- ❑ Throughout this document VTR, DDR, VDR & Video Server will be referred to collectively as “Video Server.”
- ❑ The ST300-S/SM as the ST300.
- ❑ The ST420 SHOTBOX is referred to as “SHOTBOX.” “SHOTKEY” refers to the 1-30 switches on the SHOTBOX.
- ❑ Words surrounded by brackets, for example, [ENTER], are keys on the ST300 or the SHOTBOX. [XXX] + [XXX] means hold the two keys down simultaneously.

3. SYSTEM INSTALLATION

a. SHOTBOX

- 1) Plug one end of a standard 9-pin, RS422 serial cable, into the OUTPUT connector on the rear of the SHOTBOX. Plug the other end of the cable into the AUX connector on the rear of the ST300.
- 2) Connect the Ault Model #SW300 POWER SUPPLY into the POWER connector on the rear of the SHOTBOX. Plug the Power Supply into an outlet, 90 VAC – 240 VAC.

b. ST300-S/SM, VTR/DDR CONTROLLER

- 1) Plug one end of a 9-conductor, RS422 serial cable into the VTR 1 (3 or 4) connector on the rear of the ST300. Plug the other end of the cable into the REMOTE connector on the Video Server.
- 2) Connect the supplied POWER SUPPLY, APX #4108, into the POWER connector on the rear of the ST300. Plug the Power Supply into an outlet, 90 VAC to 240 VAC.
- 3) Connect the 9-pin connector on the supplied KBIO adapter to the AUX connector on the rear of the ST300.
- 4) Connect a standard PS2 keyboard to the PS2 connector on the supplied KBIO adapter.
- 5) Check SETUP MENU prior to using the ST300 to confirm proper Record mode and other User settable modes.
- 6) Select CONTROL MODE = ODETICS.
(See menu description)

Installation is complete.

CONNECTION DIAGRAM

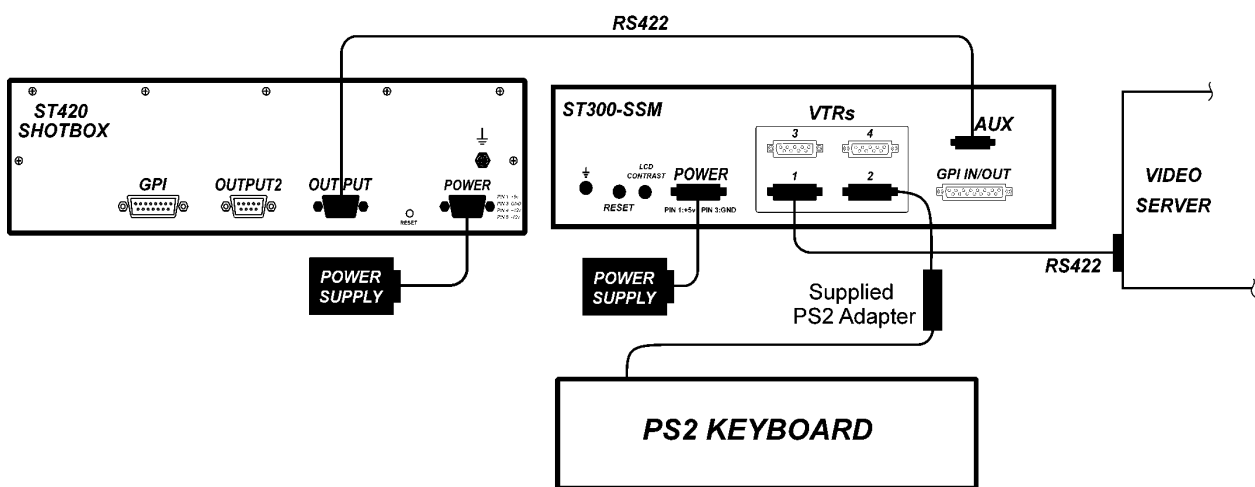

4. VIDEO SERVER SETUP

- a. Select ODETICS Broadcast communications protocol on the VIDEO SERVER to be controlled.
- b. Assign a serial port on the VIDEO SERVER through which the ST300 will control the server.

NOTES: The VIDEO SERVER may not support LTC or VITC time modes in ODETICS Broadcast mode. The ST300 will default to Tape Time if a non-supported time mode is selected on the ST300.

The Grass Valley Group PROFILE does **not** support search to a time location using Timecode (LTC or VITC) in ODETICS Protocol. Tape Time mode (TM) must be selected on the ST300.

In ODETICS Broadcast mode, the VIDEO SERVER may **ONLY** allow Full Record. INSERT and ASSEMBLE record modes may be disabled.

Setup is complete.

5. LOAD A CLIP

- a. Select a VTR by pressing VTR[1], VTR[2], VTR[3], or VTR[4].
- b. Press [CLIP LIST] to view the list of CLIP IDs that are resident on the Video Server. The CLIP LIST indicator will turn on.
- c. Press [CREATE] to create and load a new clip.
(Creating a clip is described in the CREATING A CLIP section.)
OR

Turn the Wheel to view the existing CLIP IDs on the video server.

Turn the Wheel clockwise to scroll forward, or counter-clockwise to scroll backward, through the list of available CLIPS. Backward scrolling is limited to the last 10 CLIP IDs viewed.

OR

Manually enter a CLIP ID using the ST300 numeric keypad, or PC keyboard (if KBIO option).

OR

Manually enter a Clip ID using the Qwerty keyboard on SHOTBOX.

- d. Press [LOAD] to load the selected CLIP ID for playout.
- e. Locate the clip to the desired IN time. Press [IN] to mark the IN time.
- f. Locate the clip to the desired OUT time. Press [OUT] to mark the OUT time.
- g. Repeat steps a. – f. until clips are loaded into the desired VTRs.
- h. Set the GANG mode, if required.

6. VIEW THE CLIP ID OF THE CURRENTLY LOADED CLIP

Press **[SHIFT]** + **[LOAD]**. The bottom line will show the name of the loaded clip.

7. LEARN A CLIP OR CLIP COMBINATION

a. LEARN ON THE SHOTBOX

- 1) Load clip(s) on the desired VTRs. (See Section 5, “LOAD A CLIP.”)
- 2) Press **[LEARN]**. The LEARN indicator will turn on.
- 3) Select the desired BANK and ShotKey.
- 4) Press **[LEARN]** to exit at anytime.
NOTE: The **[LEARN]** key toggles LEARN mode on/off.

The controller will: LEARN (save) the VTR Number (1,2,3,4), loaded CLIP ID and current IN and OUT time to the selected Cue Point.

b. LEARN ON THE ST300

- 1) Load clip(s) on the desired VTRs. (See Section 5, “LOAD A CLIP.”)
- 2) Select the desired Cue Point by pressing **[NEXT CUE]**, **[LAST CUE]** or by manually entering the Cue Point using the numeric keypad.

The selected Cue Point number is shown on the bottom line of the display.

- 3) Press **[SHIFT]** + **[MARK]** to initiate the LEARN.

The display will show:

Press VTR: MARK-Lrn ESC-Cancel

- 4) Press the VTR key desired: **[1]**, **[2]**, **[3]**, **[4]**.
- 5) Press **[MARK]** and the ST300 will:
LEARN (save) the VTR Number (1, 2, 3, 4), loaded CLIP ID and current IN/OUT time to the selected Cue Point.

8. RECALL A CLIP OR CLIP COMBINATION

a. RECALL ON THE SHOTBOX

- 1) Select the desired Bank.
- 2) Press the desired shotkey.

The ST300 will automatically load the learned clips on the learned VTRs, cue the clips to the Learned time, then set the Learned Gang Mode. If RECALL MODE, in the Setup Menu, is set to REDIR, and a cue point contains only one clip, then the clip will be REDIRECTED to load on the currently selected VTR, not the Learned VTR.

b. RECALL ON THE ST300

- 1) Select the desired Cue Point by pressing [NEXT CUE], [LAST CUE] or by manually entering the Cue Point on the numeric keypad.

The selected Cue Point number is on the bottom line of the display.

- 2) Press [LOAD].

The ST300 will automatically load the Learned clips on the Learned VTRs, cue the clips to the Learned time, then set the Learned GANG mode. If RECALL MODE, in the Setup Menu, is set to REDIR, and a cue point contains only one clip, then the clip will be REDIRECTED to load on the currently selected VTR, not the Learned VTR.

9. RECUE THE CURRENTLY LOADED CLIP

Press [RECUE]. If an IN Point is marked (the IN indicator is on), the clip will RECUE to the IN Point.

If the IN point is not marked, the clip will RECUE to the start of the clip.

OR

Press [SHIFT] + [RECUE].

- a. Enter the desired time to search to using the ST300's numeric keypad.
- b. Press [ENTER] to search to the entered time.

OR

Press [ESC] to exit without searching.

10. PLAY CLIP

- a. Load a clip from Cliplist or Recall a learned clip.
- b. Mark IN (OUT) points if desired. (See Section 12, “**SETTING THE IN (OUT) POINTS.**”)
- c. Press [**PLAY**].
The clip will play from the current point to the OUT point or, if no OUT point is marked, to the end of the clip.
If Autorecue Option is ON (see Setup Menu), the clip will recue to the IN point (or the beginning of the clip) once the OUT point (or the end of the clip) is reached.

11. LOOP CLIP

- a. LOAD a clip from CLIPLIST or RECALL a learned clip.
- b. Press [**LOOP ENABLE**] to loop a loaded clip. The LOOP ENABLE indicator will turn on. The second line of the display will show “Looping clip . . .”
OR
- c. Press [**STOP**] to stop the loop play.

If the clip ID ends with an asterisk (“*”), it will automatically loop when either [**LOOP ENABLE**] or [**PLAY**] is pressed.

12. SETTING THE IN (OUT) POINTS

a. MARKING THE IN (OUT) POINT

- 1) Locate the clip to the desired IN (OUT) time.
- 2) Press **[IN]** (**[OUT]**) to set the IN (OUT) Point. The IN (OUT) indicator will turn on.
The display will show “IN (OUT) xx:xx:xx:xx” where xx:xx:xx:xx is the saved time.

b. ENTERING THE IN (OUT) POINTS

- 1) Press **[SHIFT]** + **[IN]** (**[OUT]**) to manually enter a new IN (OUT) time.
- 2) Press **[ENTER]** to save the entered time or press **[ESC]** to exit without saving.

c. VIEWING THE IN (OUT) POINTS

- 1) When the IN (OUT) indicator is on,
Press **[IN]** (**[OUT]**) to view the existing IN (OUT) Point.
- 2) While viewing the IN (OUT) Point:
Press **[MARK]** to overwrite the saved time with the current time.
Press **[RECUE]** to search to the IN (OUT) point.

d. CLEARING THE IN (OUT) POINT

Press and hold **[DEL]**, then press and release **[IN]** (**[OUT]**).
The IN (OUT) indicator goes off.

13. BVW MODE

If you wish to control a tape machine or a DDR with the 2034CL-O system, select control MODE=BVW (see Setup Menu section). In this mode, the media is accessed by timecode, not by clip names. The cuepoints in BVW mode consist only of IN point, OUT point and Gang information.

The following functions are not available in BVW mode:

- View Clip ID
- Recue Clip
- Loop Clip
- Capture
- Create Clip

All other functions work as described in the manual.

14. LEARN A CLIP OR CLIP COMBINATION (BVW MODE)

- a. Select the desired Cue Point by pressing [**NEXT CUE**], [**LAST CUE**], or by manually entering the Cue Point using the numeric keypad.

The selected Cue Point number is shown on the bottom line of the display.

- b. Locate the clip to the desired IN time. Press [**IN**] to mark the IN time.
- c. Locate the clip to the desired OUT time. Press [**OUT**] to mark the OUT time.
- d. Press [**SHIFT**] + [**MARK**] to start the LEARN.

The first line of the display will show "Select VTRs:"

The second line of the display will show "Mark-Lrn, ESC-cancel."

- e. Press VTR[**1**], VTR[**2**], VTR[**3**] or VTR[**4**] to select the VTR to be learned into the current Cue Point.

If the VTRs are ganged, select one VTR that is part of the Gang. The rest of the Gang will learn automatically.

- f. Press [**MARK**] to complete the LEARN.

OR

Press [**ESC**] to exit without LEARNING.

The ST300 will: LEARN (save) the VTR number (1,2,3,4) and current IN & OUT time to the selected Cue Point.

Advanced Features . . .

15. CREATING A CLIP

- a. Press [**CLIP LIST**]. The display will show “CREATE NEW CLIP.”
- b. Press [**LOAD**]. The display will show the default CLIP ID.
- c. Press [**LOAD**] to accept the default CLIP ID.
OR

Enter an ID with a maximum of 8 characters using the SHOTBOX’s Qwerty.

NOTE: For numbers on the SHOTBOX keyboard, use bank keys 0-9.
OR

Enter a numeric ID with a maximum of 8 characters using the ST300’s numeric keypad.

- d. Press [**LOAD**] on the ST300 to create the selected CLIP ID.
- e. If the selected CLIP ID already exists, a warning message will be displayed. To load the existing clip, press [**ENTER**]. Press [**ESC**] to exit without loading the existing clip.

16. CAPTURE FUNCTION

The CAPTURE function allows source material from a VTR to be easily and quickly recorded into the VIDEO SERVER. A CLIP ID is also created.

VTR1 is always the Recorder (the VIDEO SERVER).

Select VTR[2], VTR[3] or VTR[4] as the source VTR. Any RS422, SONY protocol compatible VTR can be used.

Use the transport function keys to control the source VTR. Each source VTR has its own set of IN and OUT points.

a. ENTER PREROLL VALUE

- 1) Press [**MENU**] and turn the Wheel to “Enter PREROLL:”
- 2) Enter the desired preroll value using the ST300’s numeric keypad.
- 3) Press [**ENTER**] to save the entered value.
OR

Press [**ESC**] to exit without saving.

b. EXECUTE CAPTURE FUNCTION

- 1) Press VTR[2], VTR[3], or VTR[4] to select the source VTR.
- 2) Set IN and OUT points as described in Section 12, “SETTING THE IN (OUT) POINTS,” on the source VTR.
- 3) Press [SHIFT] + [RECORD]. The display will prompt you for a CLIP ID. A default CLIP ID will be shown.
- 4) Press [LOAD] to accept the default CLIP ID.

OR

Enter a name with a maximum of 8 characters using the SHOTBOX Qwerty keyboard.

OR

Use [NEXT CUE], [LAST CUE] and Wheel to edit the CLIP ID. Use the [NEXT CUE] and [LAST CUE] keys to position the cursor. Turn the Wheel to select the desired letter.

OR

Manually enter a numeric ID using the numeric keypad.

Press [LOAD] to accept the CLIP ID. The ST300 will create the new CLIP ID on the Video Server.

The Source VTR will preroll to the IN Point, then play. At the source VTR’s IN point, the RECORDER will go into record.

At the Source VTR’s OUT point, the RECORDER will terminate record, post-roll for 2 seconds, then stop.

The Source VTR will search to the OUT point and stop. The OUT point will be cleared. The IN indicator will stay on. The OUT indicator will turn off.

17. VIEW SHOTBOX SHOTKEY ASSIGNMENTS

- a. Press and hold [VIEW]. The VIEW indicator comes on.
- b. Press and hold the desired shotkey.
- c. The switch turns RED and the content (CLIP ID) is displayed on a virtual display.

For Example:

VTR 1 Clip 23	VTR 2 Clip 13	VTR 3 Clip 77	VTR 4 No Assignment
------------------	------------------	------------------	------------------------

NOTE: All the remaining switches are not illuminated.

- d. Release the keys to return to normal operation.

18. SHOTBOX SHOTKEY MAPS

The SWITCHES on the SHOTBOX access the SHOTLIST locations as follows:

BANK 0, SWITCHES 1 → 30 access Cue Point locations 001 → 030.
BANK 1, SWITCHES 1 → 30 access Cue Point locations 101 → 130.
BANK 2, SWITCHES 1 → 30 access Cue Point locations 201 → 230.
BANK 3, SWITCHES 1 → 30 access Cue Point locations 301 → 330.
BANK 4, SWITCHES 1 → 50 access Cue Point locations 401 → 430.
BANK 5, SWITCHES 1 → 30 access Cue Point locations 501 → 530.
BANK 6, SWITCHES 1 → 30 access Cue Point locations 601 → 630.
BANK 7, SWITCHES 1 → 30 access Cue Point locations 701 → 730.
BANK 8, SWITCHES 1 → 30 access Cue Point locations 801 → 830.
BANK 9, SWITCHES 1 → 30 access Cue Point locations 901 → 930.

19. SHOTBOX CONTROL SWITCHES

- a. **[PLAY]**: Plays out the selected clip.
- b. **[RECUE]**: Returns to the beginning of the clip.
- c. **[STOP]**: Stops ployout of the clip.
- d. **[SHIFT] + [SHOTKEY]**: Clears the contents of the pressed shotkey.

20. CLEAR SINGLE CUEPOINT

On the Shotbox, press **[SHIFT]** + the Shotkey, the content of which you wish to clear. The Shotkey becomes blank, the corresponding cuepoint is cleared.

21. TRANSFER CUE LIST

a. TRANSMIT CUE LIST FUNCTION

The TRANSMIT CUE LIST function allows you to transmit your list of Cue Points to a PC, using the provided utility software on the PC, or to another ST300. Transfer to a PC requires OpSuite 3.0 software, which runs on a Windows-based computer. Contact DNF Controls for more information.

1) To Transmit Cue Points to Another ST300

- a) Connect the VTR4 connector on the rear of the ST300 to the VTR4 connector of the receiving ST300 using an RS422 9-pin cable with TX and RX lines crossed. (A “turnaround” cable.)
- b) Press [MENU].
- c) Scroll the Wheel until “Transmit CUE list? YES=Enter, Exit=ESC” is displayed.
- d) Press [ENTER] to start transmitting. The Display shows “Waiting to transmit” on the first line.
- e) When the Receiver is ready, transfer starts automatically. The Display now shows “Transmitting cuelist.”
- f) After the transfer is over, the display shows “Transfer is over” for one second and then shows “Waiting to transmit” again.
- g) Connect another ST300 to transmit the list again.

OR

Press [ESC] twice to exit the MENU mode.

2) To Transmit Cue Points to a PC

- a) Connect the VTR4 connector on the back of the ST300 to one of the COM ports on the PC using a RS422 to RS232 adapter.
- b) Repeat steps a) thru g) of “To Transmit Cue Points to Another ST300” section.

b. RECEIVE CUE LIST FUNCTION

The RECEIVE CUELIST function allows you to receive a list of Cue Points from a PC or from another ST300. Transfer to a PC requires OpSuite 3.0 software, which runs on a Windows-based computer. Contact DNF Controls for more information.

1) To Receive Cue Points From Another ST300

- a) Connect the VTR4 connector on the back of the ST300 from the VTR4 connector of the transmitting ST300 using RS422 9-pin cable with TX and RX lines crossed.
(A “Turnaround” Cable)
- b) Press [MENU].
- c) Scroll the Wheel until “Receive CUE List? YES=Enter, Exit=ESC” is displayed.
- d) Press [ENTER] to start receiving.
The Display shows “Waiting to receive” on the first line.
- e) When the Transmitter is ready, transfer starts automatically.
The Display now shows “Receiving cuelist.”
- f) After the transfer is over the display shows “Done-Success! Press any key...”
- g) Press any key. The display shows “Receive cuelist?” message.
- h) Press [ESC] to exit the MENU mode.

2) To Receive Cue Points From the PC

- a) Connect the VTR4 connector on the back of the ST300 to one of the COM ports on the PC using RS422 to RS232 adapter.
- b) Repeat steps a) – h) of “To Receive Cue Points From Another ST300” section.

Reference . . .

22. SETUP MENU

Press [MENU]. The MENU indicator will turn on.

Turn the Wheel to select item to change.

Press [MENU] **OR** use the Softkeys to change the desired mode for that option.

Turn the Wheel at anytime to select another item.

Press [ESC] at anytime to exit SETUP MENU. The MENU indicator will turn off.

<u>MENU MODES</u>	<u>(Turning Wheel Clockwise)</u>								
RECORD	Press Softkey to select the desired record mode: Assemble, Insert, Lockout or Crash (Full).								
WIND MODE	Press Softkey to select: HOLD (fast wind is maintained only while key is depressed). OR LATCH (fast wind is initiated and maintained with momentary key press). Select fast wind speed (03.9X, etc.) by pressing Softkey.								
SLOMO	<div style="display: flex; justify-content: space-between;"> <div data-bbox="440 1073 672 1129">ST300 display shows (Non T-Bar version):</div> <div data-bbox="821 1073 1297 1192" style="border: 1px solid black; padding: 5px;"> <table style="width: 100%; border-collapse: collapse;"> <tr> <td style="width: 60%;">SLOMO with:</td> <td style="text-align: right;">WHEEL</td> </tr> <tr> <td>SpdRange</td> <td style="text-align: right;">Preset</td> </tr> </table> </div> </div> <div style="display: flex; justify-content: space-between; margin-top: 10px;"> <div data-bbox="440 1226 672 1283">ST300 display shows (T-Bar version):</div> <div data-bbox="821 1226 1297 1331" style="border: 1px solid black; padding: 5px;"> <table style="width: 100%; border-collapse: collapse;"> <tr> <td style="width: 60%;">SLOMO with:</td> <td style="text-align: right;">TBAR</td> </tr> <tr> <td>Wheel SpdRange Preset</td> <td></td> </tr> </table> </div> </div> <p data-bbox="440 1381 1292 1413">Press Softkey [TBAR] (or [WHEEL]) to toggle between T-BAR and WHEEL.</p> <p data-bbox="440 1444 1450 1476">NOTE - The T-BAR has a fixed speed range of 0 → +200 with a detent at +100% play speed.</p> <p data-bbox="440 1507 630 1539">For Wheel only:</p> <p data-bbox="440 1539 1105 1570">Press Softkey [SPDRANGE] to select SLOMO speed ranges:</p> <p data-bbox="440 1602 1008 1633">Press Softkey to select 0 → +200 OR -100 → +200.</p> <p data-bbox="440 1633 1008 1665">Press Softkey [BACK] to return to SLOMO MENU.</p> <p data-bbox="440 1696 829 1728">Press [ESC] to exit SETUP MENU.</p> <p data-bbox="440 1728 889 1759">OR turn the Wheel to select another item.</p> <p data-bbox="440 1822 724 1854">(Continued on next page.)</p>	SLOMO with:	WHEEL	SpdRange	Preset	SLOMO with:	TBAR	Wheel SpdRange Preset	
SLOMO with:	WHEEL								
SpdRange	Preset								
SLOMO with:	TBAR								
Wheel SpdRange Preset									

	<p>For Wheel only: Press Softkey [PRSET] to select the SLOMO Preset Speed Mode.</p> <p>Press Softkey [UPDATE]. When exiting SLOMO mode, the last used speed is saved in the Preset Speed register.</p> <p>OR Press Softkey [STATIC]. The Preset Speed register is NOT updated when exiting SLOMO mode. It is only changed by [SHIFT] + [SLOMO] (PRESET SLOMO).</p>
GANG MODE	<p>Press Softkey to select PERMANENT GANG (described in the FUNCTION Table) or TEMPORARY GANG.</p> <p>In TEMPORARY mode, press and hold the VTR key that you want to read status from, then press the VTR#s of those VTRs that you want to include in the gang. Release the keys. The LED on the monitored VTR blinks, all other VTRs in the gang stay on constantly. To break the temporary gang, press any VTR# key.</p>
ST300 SETUP	<div style="border: 1px solid black; padding: 5px; margin-bottom: 10px;"> <p style="text-align: center;">ST300 SETUP</p> <p style="text-align: center;">Clear Cues SetDefault</p> </div> <p>Press Softkey beneath ClearCues to clear all Cue Points to 00:00:00:00. Press Softkey [YES] when asked “Are You Sure?”</p> <p>Press Softkey beneath SetDefault to set ST300 to default settings. Press Softkey [YES] when asked “Are You Sure?”</p> <p>IMPORTANT NOTE: Please set these items during initial installation.</p>
DISPLAY SOFTWARE VERSION	<p>The version number and date for the currently installed software is displayed. For example:</p> <div style="border: 1px solid black; padding: 5px; margin: 10px auto; width: fit-content;"> <p style="text-align: center;">2034CL-O V3.1</p> <p style="text-align: center;">072400</p> </div>
SYNC	<p>Set to ON if black burst is supplied to the Ref Video connector on the rear panel. Set to OFF if no blackburst is supplied.</p>
AUTO RECUE	<p>If Set to [ON] the video automatically recues back to the IN point (or to the beginning of the clip if there is no IN point) after the playout reaches OUT point (or the end of the clip).</p>
RECORD	<p>Press Softkey to select single button or 2-button record. RECORD = [REC] Only.</p> <p>OR [REC] + [PLAY].</p>
RECALL MODE	<p>Press [NORMAL] or [REDIR] (redirect).</p> <p>NORMAL - The cue point will load on the learned VTR.</p> <p>REDIR - When one and only one clip is learned into a Cue Point, the Clip will be REDIRECTED to load on the currently selected VTR.</p>

ENTER PREROLL	Enter the desired preroll value using the ST300's numeric keypad. Turn wheel to save the entered value OR press [ESC] to exit without saving.
RECORD DELAY	Enter up to 99 frames record delay (used in Capture Function). Typical value is 3 frames.
CONTROL MODE SELECT	Select Control mode Odetics\BVW. Have Odetics selected for video server control and clip access. Have BVW selected to access media by timecode.
TRANSMIT CUELIST	Transmit Cuelist to another ST300 or to a PC. See Section: "Transfer Cue List."
RECEIVE CUELIST	Receive Cuelist from another ST300 or a PC. See Section: "Transfer Cue List."

23. FUNCTION TABLE

FUNCTION	KEY PRESS	DESCRIPTION
GOTO ENTERED TIME	[SHIFT] + [RECUE]	Search the VTR to the manually entered time. Use the ST300 numeric keypad. To manually enter the desired time press [ENTER] or [RECUE]. NOTE: GRASS VALLEY GROUP Profile does not support TC or VITC time search.
GANG	[SHIFT]+[VTR #1] OR [SHIFT]+[VTR #2] OR [SHIFT]+[VTR #3] OR [SHIFT]+[VTR #4]	Individually press the VTR keys to be included in the gang; the LED above the key will turn on. Press the VTR key again to remove from gang; the LED above the key will turn off. Press [ESC] to exit. The VTR LEDs that are on show the gang. The flashing LED shows which VTR is currently selected.
FFWD	[FFWD]	Press and HOLD to FFWD. Release key to stop. Set WIND Speed in MENU.
JOG	[JOG]	Select JOG mode and enable Wheel.
LAST CUE	[LAST CUE]	Step to the previous Cue Point Location.
LOOP	[SHIFT] + [PLAY]	Play the currently loaded clip in a continuous loop.
NEXT CUE	[NEXT CUE]	Step to the next Cue Point Location.
RECORD	[REC]	Places VTR into the Record mode selected by RECORD MODE in the SETUP MENU. Press [RECORD] or [RECORD] + [PLAY].
REWIND	[RWD]	Press and HOLD to REWIND. Release key to stop. Set WIND Speed in MENU.
SHUTTLE	[SHUTTLE]	Select SHUTTLE mode and enable Wheel.
SLOMO	[SLOMO]	Press [SLOMO] to slo-mo the VTR. Turn the Wheel (or move the T-Bar, if available) to change the play speed. Press [SLOMO] to STILL frame, OR press any transport key to exit SLOMO.
SLO-MO SPEED PRESET	[SHIFT] + [SLOMO]	For WHEEL ONLY : Press [SHIFT] + [SLOMO] to preset the slo-mo speed. Turn the Wheel to select desired speed. Press [ESC] or any transport key to exit.
STOP	[STOP]	Press once to STILL frame VTR. Press again to put VTR into STOP mode.
TIME MODE SELECT	[TIME MODE]	Press to toggle between Timecode (TC), VITC (VT) or Tape Timer (TM) display modes.
LOOP CLIP	[LOOP ENABLE]	Press to loop a whole clip or a part between IN and OUT points (if marked).

FUNCTION	KEY PRESS	DESCRIPTION
PLAY	[PLAY]	Plays the clip. If the OUT point is set, stops at the OUT point. If no OUT point is set, plays to the end of the clip. If the clip ends with "*", loops the clip.
PLAY TO THE END OF THE CLIP	[SHIFT] + [PLAY]	Plays to the end of the clip. Disregards the OUT point and the "*".
ALIGN GANGED CHANNELS	[SHIFT] + [STOP]	Reestablishes the initial offset between ganged channels.

24. SPECIFICATIONS

a. ST300

Power:	90 VAC to 265 VAC adapter supplied with IEC connector
Size:	(L" x W" x H") 12" x 6" x 1.5" (front) 3.0" (rear) (T-Bar unit is 12.6" wide)
Weight:	4 lbs.
Rear Panel Connectors:	VTR1, VTR2, VTR3, VTR4 (All DB9F) GPI (DBF15F) Power (DB9M) Aux (DB9F) Reference Video (BNC)
Display:	Easy to read 2-line, back-lit LCD display (User adjustable contrast)
Jog/Shuttle Wheel:	With mechanical detents.
Optional "T"-bar:	Slo-mo 0-200% of Play Speed

VTR RS422 SERIAL CONNECTOR

9-Pin D-Type, Female

Pin #	1	Frame Ground	6	Receive Common
	2	Receive A ←	7	Receive B ←
	3	Transmit B →	8	Transmit A →
	4	Transmit Common	9	Frame Ground
	5	Spare		

POWER CONNECTOR

9-Pin D-Type, Male

Pin #	1	+5v DC	6	+5 VDC
	2	+5v DC	7	Ground
	3	Ground	8	Ground
	4	+12 VDC	9	Ground
	5	-12 VDC		

AUX PORT RS422 SERIAL CONNECTOR

9-Pin D-Type, Female

Pin #	1	Frame Ground	6	Receive Common
	2	Receive A ←	7	Receive B ←
	3	Transmit B →	8	Transmit A →
	4	Receive Common	9	Frame Ground
	5	Spare		

GPI IN/OUT CONNECTOR 15-Pin D-Type, Female (DB15F)

Pin #	Description	Function	Pin #	Description	Function
1	GPI 1 Out		9	GPI 1 In	Play
2	GPI 2 Out		10	GPI 2 In	Stop
3	GPI 3 Out		11	GPI 3 In	Recue
4	GPI 4 Out		12	GPI 4 In	Next Cue
5	GPI 5 Out		13	GPI 5 In	Last Cue
6	GPI 6 Out		14	GPI 6 In	Recall
7	GPI 7 Out		15	GPI 7 In	
8	Ground				

b. ST420 (SHOTBOX)

Power: +5v DC @ 4A, +12v DC @ 1.0A, -12v DC @ 0.6A
90 VAC to 265 VAC adapter supplied with IEC connector

Size: [L" x W" x H"] 11.5" x 6.5" x 1.75" (front)
3.5" (rear)

Weight: 4 lbs.

Rear Panel Connectors: Power: DB9M
OUTPUT: ... DB9F

RS422 SERIAL CONNECTOR 9-Pin D-Type, Female

Pin #	1	Frame Ground	6	Transmit Common
	2	Transmit A →	7	Transmit B →
	3	Receive B ←	8	Receive A ←
	4	Receive Common	9	Frame Ground
	5	Spare		

POWER CONNECTOR 9-Pin D-Type, Male

Pin #	1	+5v DC	6	+5 VDC
	2	+5v DC	7	Ground
	3	Ground	8	Ground
	4	+12 VDC	9	Ground
	5	-12 VDC		

25. TROUBLESHOOTING

ST420 TROUBLESHOOTING

- a. All keys are RED - no communication with ST300.
- b. All keys are dark - no communication between the ST300 and the Video Server.
- c. The version of the ST420 must comply in the software version with the ST300 it is connected to.

To determine the software version of the ST420 do the following:

- 1) Press **[SHIFT]** + **[STOP]** + **[PLAY]**.
The key that displays the current version is RED.
- 2) The ST420 displays:
“SELECT ST300 V2.1 or V2.0 or V3.0.”

Press the key for the software version of ST300 being used.
Please refer to the ST300 to determine the Version if needed.

26. KEY LAYOUT

ST300 KEY CONFIGURATION 2034CL-0 & 4000CL-0 V3.1 (& -T, & -PBIO)

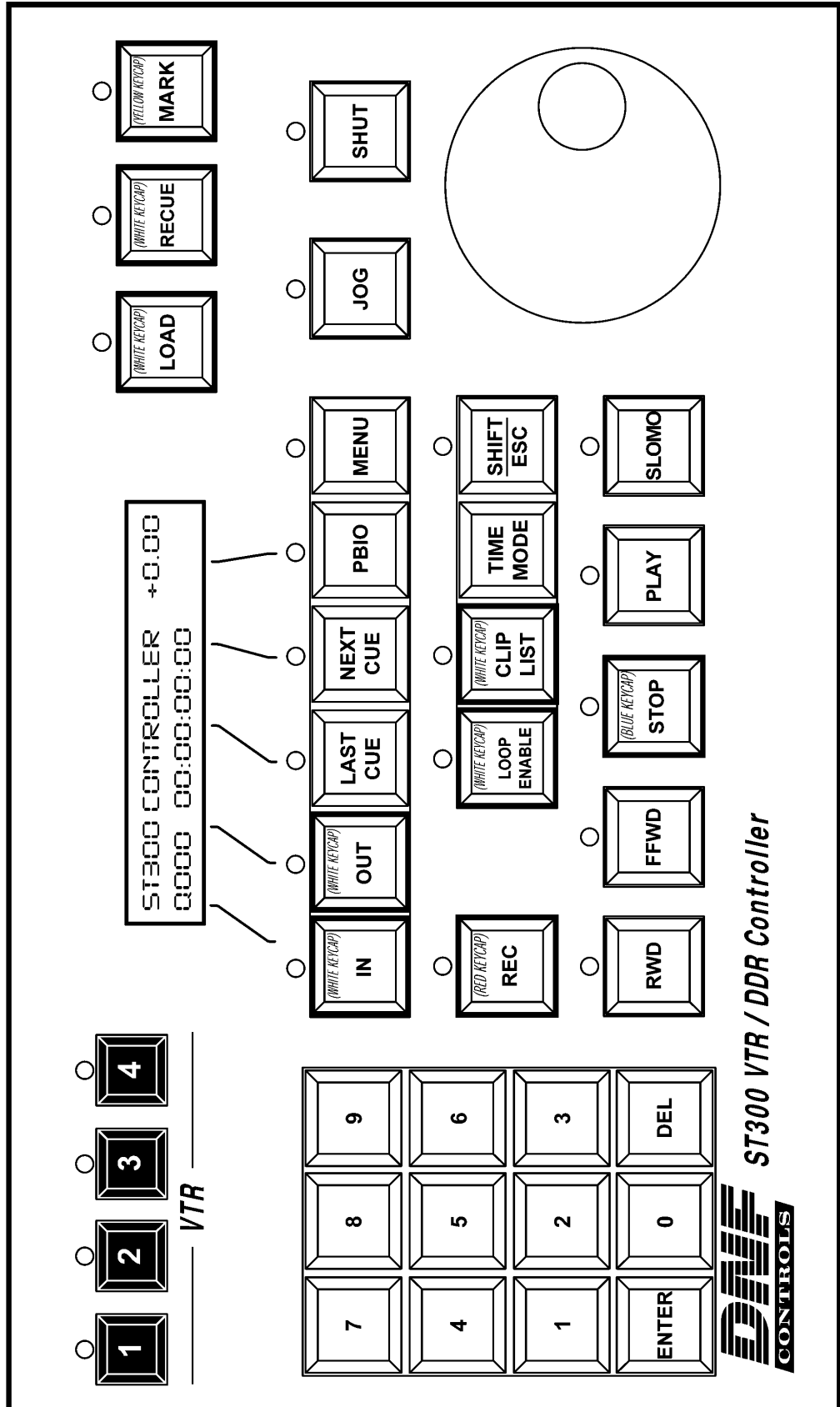

27. DNF CONTROLS LIMITED WARRANTY

DNF Controls warrants its product to be free from defects in material and workmanship for a period of one (1) year from the date of sale to the original purchaser from DNF Controls.

In order to enforce the rights under this warranty, the customer must first contact DNF's Customer Support Department to afford the opportunity of identifying and fixing the problem without sending the unit in for repair. If DNF's Customer Support Department cannot fix the problem, the customer will be issued a Returned Merchandise Authorization number (RMA). The customer will then ship the defective product prepaid to DNF Controls with the RMA number clearly indicated on the customer's shipping document. The merchandise is to be shipped to:

DNF Controls
12843 Foothill Blvd., Suite D
Sylmar, CA 91342
USA

Failure to obtain a proper RMA number prior to returning the product may result in the return not being accepted, or in a charge for the required repair.

DNF Controls, at its option, will repair or replace the defective unit. DNF Controls will return the unit prepaid to the customer. The method of shipment is at the discretion of DNF Controls, principally UPS Ground for shipments within the United States of America. Shipments to international customers will be sent via air. Should a customer require the product to be returned in a more expeditious manner, the return shipment will be billed to their freight account.

This warranty will be considered null and void if accident, misuse, abuse, improper line voltage, fire, water, lightning or other acts of God damaged the product. All repair parts are to be supplied by DNF Controls, either directly or through its authorized dealer network. Similarly, any repair work not performed by either DNF Controls or its authorized dealer may void the warranty.

After the warranty period has expired, DNF Controls offers repair services at prices listed in the DNF Controls Price List. DNF Controls reserves the right to refuse repair of any unit outside the warranty period that is deemed non-repairable.

DNF Controls shall not be liable for direct, indirect, incidental, consequential or other types of damage resulting from the use of the product.

###