



12843 Foothill Blvd.,
Suite D
Sylmar, CA 91342
818 898 3380 voice
818 898 3360 fax
www.dnfcontrols.com

Model No. 2044CL-O-PBIO-7 (& 2044CL-O-T-PBIO-7)

300 CLIP INSTANT ACCESS SYSTEM

Odetics Protocol

USER MANUAL

Table of Contents

1.	REVISION HISTORY	4
	<i>GETTING STARTED . . .</i>	5
2.	SYSTEM DESCRIPTION	5
	DEFINITIONS	5
3.	SYSTEM INSTALLATION	6
	A. SHOTBOX	6
	B. ST400-S/SM, VTR/DDR CONTROLLER	6
	C. PRODUCTION SWITCHER	6
4.	VIDEO SERVER SETUP	8
5.	LOAD A CLIP	8
	ON THE ST400	8
6.	LEARN A CLIP OR CLIP COMBINATION	9
	A. ON THE ST400 (ODETICS)	9
	B. ON THE ST400 (BVW)	10
	C. ON THE SHOT BOX	10
	D. ON THE PRODUCTION SWITCHER	10
7.	RECALL A CLIP OR CLIP COMBINATION	11
	A. ON THE SHOTBOX	11
	B. ON THE PRODUCTION SWITCHER	11
8.	RECUE CLIP	11
9.	LEARN FROM THE ST400	12
	ON THE ST400	12
10.	RECALL FROM THE ST400	12
11.	CLEAR CUE POINTS	13
	A. ON THE ST420 SHOTBOX	13
	B. ON THE ST400	13
12.	LOOP CLIP	13
	ON THE ST400	13
13.	PLAY CLIP SEGMENT	14
14.	PBIO ENABLE/DISABLE	14
	ON THE ST400	14
15.	PRODUCTION SWITCHER PBIO TRIGGER VALUES	15
	GRASS VALLEY GROUP PRODUCTION SWITCHER	15
	SONY PRODUCTION SWITCHER	15
16.	TIMECODE SEARCH	16
17.	BVW MODE	16

ADVANCED FEATURES . . . **17**

18. SHOTBOX SHOTKEY MAPPING TO SHOTLIST LOCATIONS AND E-MEM REGISTERS	17
19. SHOTBOX CONTROL SWITCHES	17
20. CREATING A CLIP	17
ON THE ST400	17
21. CAPTURE	18
22. VIEW SHOTKEY ASSIGNMENTS	19
ON THE SHOTBOX	19
23. CREATE CUE POINT LABELS	19
ON THE ST400	19

REFERENCE . . . **20**

24. SETUP MENU	20
25. FUNCTION TABLE	23
26. SPECIFICATIONS	25
A. ST400	25
B. ST420 (SHOTBOX)	27
27. TROUBLESHOOTING	28
A. ST420 TROUBLESHOOTING	28
B. PBIO TROUBLESHOOTING	28
28. KEY LAYOUT	29
29. DNF CONTROLS LIMITED WARRANTY	30

Manual Version..... 1.4 063005
Document ID..... 2044CL-O-PBIO-7_User_Manual.doc

1. REVISION HISTORY

052104	1.0	Original document.
080404	1.1	Added (ODETICS MODE) to LEARN ON THE ST400 section. Added LEARN ON THE ST400 (BVW MODE) section. Added BVW MODE section.
080504	1.2	Revised Connection Diagram.
120104	1.3	Updated ST420 Troubleshooting section.
063005	1.4	Added Video Reference instructions.

Getting Started . . .

2. SYSTEM DESCRIPTION

The 2044CL system includes DNF's most robust controller, the ST400, with the industry's premiere Shotbox, the ST420.

The ST400 controls up to 7 video channels individually or ganged. It features full transport functionality.

The LCD buttons on the Shotbox display clip names and delivery instant access to video clips on up to 6 channels.

The assign-able keys on the ST420 Shotbox allow clip names to be organized on ten different banks of keys for easy access.

The 2044CL provides instant access to fill clip and key clip combinations with the press of one key.

The 2044CL-O supports Odetics Broadcast protocol and requires that the Video Server be controllable under Odetics Broadcast Protocol.

The 2044CL provides instant access to existing video clips stored in the Grass Valley Group PROFILE, the Leitch VR, and other Video Servers supporting Odetics Broadcast Protocol.

DEFINITIONS

- ❑ Throughout this document, DDR, VDR & Video Server will be referred to collectively as "Video Server."
- ❑ The ST400-S/SM will be referred to as ST400.
- ❑ The ST420 SHOTBOX will be referred to as "Shotbox." SHOTKEY refers to the 1-30 switches on the Shotbox.
- ❑ Words surrounded by brackets, for example, [ENTER], are keys on the ST400 or the SHOTBOX. [XXX] + [XXX] means hold the two keys down simultaneously.
- ❑ The 6 keys directly below the display are referred to as "Softkey." Their function changes as indicated on the last line of the display.
- ❑ Shotkeys and Cue Points refer to the same memory locations. Both terms are interchangeable.

3. SYSTEM INSTALLATION

a. SHOTBOX

- 1) Plug one end of a standard 9-pin, RS422 serial cable into the OUTPUT connector on the rear of the Shotbox. Plug the other end of the cable into the “SHOTBOX” connector on the rear of the ST400.
- 2) Connect the supplied POWER SUPPLY, AULT#SW300, into the POWER connector on the rear of the SHOTBOX. Plug the Power Supply into an outlet, 90 VAC – 240 VAC.

b. ST400-S/SM, VTR/DDR CONTROLLER

- 1) Plug one end of a 9-conductor, RS422 serial cable into the VTR1 (2, 3, 4, 5, 6 or PBIO) connector on the rear of the ST400. Plug the other end of the cable into the 9-pin REMOTE connector on the Video Server.
- 2) Connect the supplied POWER SUPPLY, APX #4108, into the POWER connector on the rear of the ST400. Plug the Power Supply into an outlet, 90 VAC - 240 VAC.
- 3) Check SETUP MENU prior to using the ST400 to confirm proper Record mode and other User settable modes.
Attached House Video Reference cable to Ref. Video connector on the rear of the ST400. Video Reference must be connected for frame accurate playout of ganged channels, and for Capture function.

NOTE: VTR7 is connected to PBIO connector on the back of the ST400.

c. PRODUCTION SWITCHER

- 1) Plug one end of a 9-conductor, RS422 serial cable into the “SP2” connector on the rear of the ST400. Connect the other end of the cable to the Peripheral Bus Connector on the production switcher.
- 2) Refer to the SETUP MENU section to set VTR1, VTR2, VTR3, VTR4, VTR5, VTR6 & VTR7 Pbus Device Addresses, PBIO parity to match the Production Switcher and Production Switcher type. The Pbus baud rate must be set to “38400” on the Production Switcher.

Installation is complete.

2044CL-PBIO-7 Connection Diagram

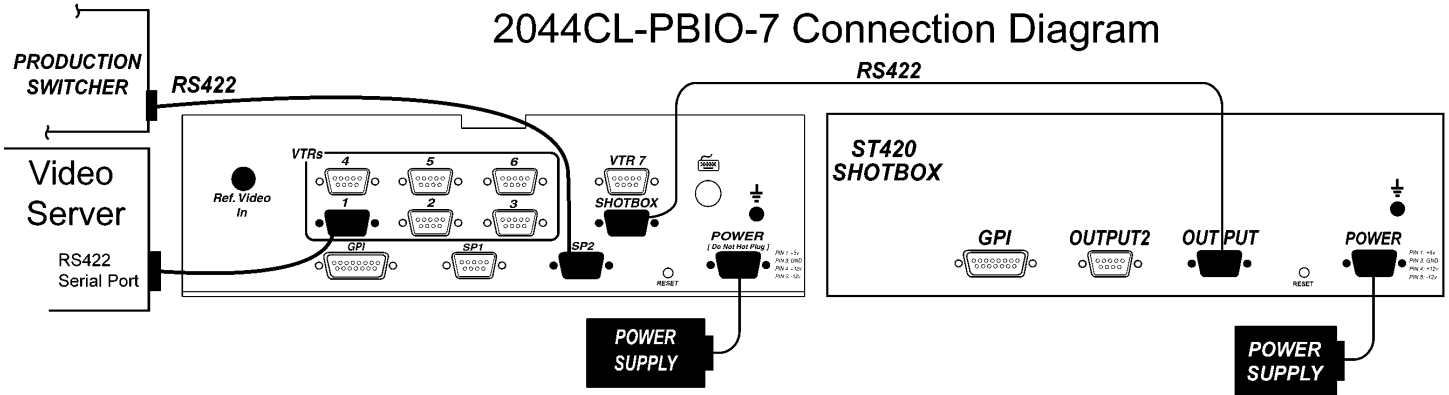

4. VIDEO SERVER SETUP

- a. Select ODETICS Broadcast communications protocol on the VIDEO SERVER to be controlled.
- b. Assign a serial port on the VIDEO SERVER through which the ST400 will control it.

NOTES: The VIDEO SERVER may not support LTC or VITC time modes in ODETICS Broadcast mode. The ST400 will default to Tape Time if a non-supported time mode is selected.

In ODETICS Broadcast mode, the VIDEO SERVER may **ONLY** allow Full Record. INSERT and ASSEMBLE record modes may be disabled.

The Grass Valley Group PROFILE does **not** support search to a time location using Timecode (LTC or VITC) in ODETICS Protocol. Tape Time mode (TM) must be selected on the ST400.

5. LOAD A CLIP ON THE ST400

- a. Select a VTR by pressing VTR [1], [2], [3], [4], [5], [6] key or [VTR7] softkey. .
- b. Press [CLIP LIST] to view the list of CLIP IDs that are resident on the Video Server. The CLIP LIST indicator will turn on.
- c. Press [CREATE] to create and load a new clip.
(Creating a clip is described in the CREATING A CLIP section.)

OR

Turn the Wheel to view the existing CLIP IDs on the video server.

Turn the Wheel clockwise to scroll forward, or counter-clockwise to scroll backward, through the list of available CLIPs. Backward scrolling is limited to the last 10 screens of CLIP IDs.

Press [LOAD] to load the highlighted CLIP ID. After loading the selected clip, the CLIP LIST function will terminate. The CLIP LIST indicator will turn off.

OR

Manually enter a Clip ID using the ST400 numeric keypad or Shotbox "QWERTY" keyboard, or PC keyboard.

Press [LOAD] to load the entered CLIP ID for playout.

- d. Repeat steps a - c to load clips on desired VTRs.

6. LEARN A CLIP OR CLIP COMBINATION

a. ON THE ST400 (ODETICS)

- 1) Press VTR [1], [2], [3], [4], [5], [6] or [VTR7] softkey to select the channel to learn.
- 2) Load a clip on the selected channel. See section LOAD A CLIP.
- 3) Use the transport functions to view the clip.

Press [IN] to mark an IN point. The IN LED will turn on.
On recall, the clip will cue to the IN time, not the beginning of the clip.

Optional: Press [OUT] to mark an OUT point. The OUT LED will turn on.
On recall, the clip will play to the OUT point then stop.

To delete an IN or OUT point, press and hold [DEL], then press [IN] or [OUT].
The IN/OUT LED will turn off.

If no IN point is marked, the current location of the clip will be learned as the IN point.

- 4) For GANGs, repeat steps 1 and 2 for each channel.

Then, press the [GANG] softkey.

Press VTR [1], [2], [3], [4], [5], [6] or [VTR7] softkey to add it to the GANG.
The VTR LED will turn on.

Press the VTR key again to remove it from the gang. The VTR LED will turn off.

Press [ESC] to exit GANG mode. The LEDs of all GANGed VTRs will turn on.

b. ON THE ST400 (BVW)

- 1) Select the desired Cue Point by pressing [**NEXT CUE**], [**LAST CUE**], or by manually entering the Cue Point using the numeric keypad.

The selected Cue Point number is shown on the bottom line of the display.

- 2) Locate the clip to the desired IN time. Press [**IN**] to mark the IN time.
- 3) Locate the clip to the desired OUT time. Press [**OUT**] to mark the OUT time.

- 4) Press [**SHIFT**] + [**MARK**] to start the LEARN.
The first line of the display will show "Select VTRs:"
The second line of the display will show "Mark-Lrn, ESC-cancel."

- 5) Press VTR[**1**], VTR[**2**], VTR[**3**] or VTR[**4**] to select the VTR to be learned into the current Cue Point.

If the VTRs are ganged, select one VTR that is part of the Gang. The rest of the Gang will learn automatically.

- 6) Press [**MARK**] to complete the LEARN.
OR

Press [**ESC**] to exit without LEARNING.

The ST300 will: LEARN (save) the VTR number (1,2,3,4) and current IN & OUT time to the selected Cue Point.

c. ON THE SHOT BOX

1. Press [**LEARN**]. The LEARN indicator will turn on.
2. Select the desired BANK by pressing BANK [**1**], [**2**], [**3**], [**4**], [**5**], [**6**], [**7**], [**8**], [**9**] or [**0**].
3. Press the desired Shotkey to complete the learn process.
The learned CLIP ID is displayed on the Shotkey.
4. Press [**ESC**] at anytime to escape without LEARNING.

d. ON THE PRODUCTION SWITCHER

Select and enable the Peripheral Device Addresses for the ST400 VTRs to learn.

LEARN to the desired EMEM or SNAPSHOT register.

NOTE: LEARN will overwrite the previous contents of the Shotkey.

7. RECALL A CLIP OR CLIP COMBINATION

a. ON THE SHOTBOX

- 1) Select the desired BANK by pressing BANK [1], [2], [3], [4], [5], [6], [7], [8], [9] or [0].
The Shotkeys will display the assigned CLIP IDs for the selected bank.
- 2) Press the desired Shotkey.
The selected clip or clip combination will be loaded on the learned channels, and cued to the learned IN point. The learned OUT point and GANG mode will be set.

b. ON THE PRODUCTION SWITCHER

RECALL the desired REGISTER.

The ST400 will automatically load the Learned clips on the Learned VTRs, set the Learned IN and OUT points, cue the clips to the Learned IN point, set the Learned GANG mode.

8. RECUE CLIP

- a. Press [RECUE]. If an IN Point is marked (the IN indicator is on), the clip will RECUE to the IN Point.

If the IN point is not marked, the clip will RECUE to the start of the clip.
- b. Press [CUE OUT] to cue to the marked OUT point.

9. LEARN FROM THE ST400

ON THE ST400

- a. Press VTR [1], [2], [3], [4], [5], [6] or [VTR7] softkey to select the channel to learn.
- b. Use the transport functions to view the clip.

Press [IN] to mark an IN point. The IN LED will turn on.
On recall, the clip will cue to the IN time, not the beginning of the clip.

Optional: Press [OUT] to mark an OUT point. The OUT LED will turn on.
On recall, the clip will play to the OUT point then stop.

To delete an IN or OUT point, press and hold [DEL], then press [IN] or [OUT].
The IN/OUT LED will turn off.

If no IN point is marked, the current location of the clip will be learned as the IN point.

- c. For GANGs, repeat steps a and b for each channel.

Then, press the [GANG] softkey.

Press VTR [1], [2], [3], [4], [5], [6] or [VTR7] softkey to add it to the GANG. The VTR LED will turn on.

Press the VTR key again to remove it from the gang. The VTR LED will turn off.

Press [ESC] to exit GANG mode. The LEDs of all GANGed VTRs will turn on.
- d. Select the desired Cue Point by pressing [NEXT CUE], [LAST CUE] or by manually entering the Cue Point using the numeric keypad, followed by [ENTER].

The selected Cue Point number is shown on the bottom part of the display.
- e. Press [SHIFT] + [LEARN] to initiate the LEARN.
The display will show: "Select VTRs to learn:-----"
- f. Select the VTRs to learn by pressing VTR keys [1], [2], [3], [4], [5], [6] and/or [7].
- g. Press [LEARN] to complete the learn process.

10. RECALL FROM THE ST400

- a. Select the desired Cue Point by pressing [NEXT CUE], [LAST CUE] or by manually entering the Cue Point using the numeric keypad.

The selected Cue Point number is shown on the bottom of the display.

- b. Press [LOAD] on the ST400.

The ST400 will automatically load the Learned clips on the Learned VTRs, cue the clips to the Learned IN time, then set the Learned GANG mode.

11. CLEAR CUE POINTS

a. ON THE ST420 SHOTBOX

- 1) Select the desired BANK by pressing the desired bank key.
- 2) Press and hold the [SHIFT] key.
- 3) Press the desired Shotkey to be cleared.
After the cue point is cleared, the Shotkey will be blank.

b. ON THE ST400

- 1) Select the cue point to be cleared using [NEXT CUE], [LAST CUE], or manually entering the cue point number.
- 2) Press [SHIFT] + [LEARN].
The CLEAR softkey will be displayed on the bottom of the display.
- 3) Press the [CLEAR] softkey to clear the cue point.
The cue point will be cleared and the display will return to the normal screen.
OR

Press [ESC] to escape without clearing.

12. LOOP CLIP

ON THE ST400

- a. Load the clip using CLIP LIST, or recall a cue point.
(The clip MUST be loaded from the 2044CL.)

- b. Optional: Set an IN Point and/or OUT Point.
Jog/Shuttle to the desired IN point. Press [IN].
Jog/Shuttle to the desired OUT point. Press [OUT].
OR

Press [SHIFT] + [IN]. Manually enter the IN time on the numeric keypad. Press [ENTER].

Press [SHIFT] + [OUT]. Manually enter the OUT time on the numeric keypad. Press [ENTER].

- c. Press [LOOP ENABLE].
The clip will immediately start looping.

NOTE: If the CLIP ID ends with an asterisk ("*"), it will automatically loop when either [LOOP ENABLE] or [PLAY] is pressed.

13. PLAY CLIP SEGMENT

- a. Set an IN Point and OUT Point.
Jog/Shuttle to the desired IN point. Press [IN].
Jog/Shuttle to the desired OUT point. Press [OUT].
OR

Press [SHIFT] + [IN]. Manually enter the IN time on the numeric keypad. Press [ENTER].

Press [SHIFT] + [OUT]. Manually enter the OUT time on the numeric keypad. Press [ENTER].
- b. Press [RECUE]. The clip will cue to the IN point.
- c. Press [PLAY].
The clip will play from its current time to the OUT point, then stop.

14. PBIO ENABLE/DISABLE

ON THE ST400

Press the [PBIO] softkey to enable or disable PBIO. When disabled, the ST400 will ignore all Pbus commands. When enabled, the ST400 will respond to all Pbus commands.

When enabled and Pbus commands are received, the softkey's LED will flash.

15. PRODUCTION SWITCHER PBIO TRIGGER VALUES

The Production Switcher outputs a Peripheral Bus trigger at specific Timeline key frames, as programmed by the operator. The 2044CL performs a specific function for each trigger value:

GRASS VALLEY GROUP PRODUCTION SWITCHER

<u>Trigger Value</u>	<u>Mode</u>
0	Play (if OUT point is specified, stop at OUT, if clip ends with “*”, Loop Play)
1	Recue to beginning of clip
2	Slo-mo using ST400 Preset Speed
3	Reverse Play
4	Still Frame
5	Loop (Odetics mode only)
6	Record
7 or greater	Play

SONY PRODUCTION SWITCHER

<u>Trigger Value</u>	<u>Mode</u>
0	Recue to beginning of clipPlay
1	Play (if OUT point is specified, stop at OUT, if clip ends with “*”, Loop Play)
2	Slo-mo using ST400 Preset Speed
3	Reverse Play
4	Still Frame
5	Loop (Odetics mode only)
6	Record
7 or greater	Play

To control more than one VTR, enable the Peripheral Device Address for each VTR. The Trigger value will be sent to the enabled devices.

OR

GANG the required VTRs on the ST400. See FUNCTION TABLE for GANG instructions. Enable the Peripheral Device Address for one of the GANGed VTRs. The Trigger will be sent to the enabled VTR. The other VTRs in the GANG will perform the same action.

16. TIMECODE SEARCH

In order to properly search by Timecode, please select Timecode = NOT SUPPORTED menu option for every channel connected to the Profile and Timecode = SUPPORTED for all other channels.

To select “Timecode” option:

- a. Press [MENU] key.
- b. Turn the wheel until TIMECODE option is highlighted.
- c. Press [CHANGE] softkey.
- d. Press a softkey to select SUPPORTED or NOT SUPPORTED setting.
- e. Press [ESC] twice to exit menu mode.

17. BVW MODE

If you wish to control a tape machine or a DDR with the 2044CL-O system, select control MODE=BVW (see Setup Menu section). In this mode, the media is accessed by timecode, not by clip names. The cuepoints in BVW mode consist only of IN point, OUT point and Gang information.

The following functions are not available in BVW mode:

- View Clip ID
- Recue Clip
- Loop Clip
- Capture
- Create Clip

All other functions work as described in the manual.

Advanced Features . . .

18. SHOTBOX SHOTKEY MAPPING TO SHOTLIST LOCATIONS AND E-MEM REGISTERS

The Shotkeys on the Shotbox access the cue point locations in the ST400 as follows:

BANK 0, Shotkeys 1 → 30 access cue point locations 001 → 030 and E-mem registers 01 → 30.
BANK 1, Shotkeys 1 → 30 access cue point locations 101 → 130 and E-mem registers 31 → 60.
BANK 2, Shotkeys 1 → 30 access cue point locations 201 → 230 and E-mem registers 61 → 90.
BANK 3, Shotkeys 1 → 09 access cue point locations 301 → 309 and E-mem registers 91 → 99.
BANK 3, Shotkeys 10 → 30 access cue point locations 310 → 330.
BANK 4, Shotkeys 1 → 50 access cue point locations 401 → 430.
BANK 5, Shotkeys 1 → 30 access cue point locations 501 → 530.
BANK 6, Shotkeys 1 → 30 access cue point locations 601 → 630.
BANK 7, Shotkeys 1 → 30 access cue point locations 701 → 730.
BANK 8, Shotkeys 1 → 30 access cue point locations 801 → 830.
BANK 9, Shotkeys 1 → 30 access cue point locations 901 → 930.

19. SHOTBOX CONTROL SWITCHES

- a. **[PLAY]**: Plays out the selected clip.
- b. **[RECUE]**: Returns to the beginning of the clip.
- c. **[STOP]**: Stops playback of the clip.

20. CREATING A CLIP

ON THE ST400

- a. Press **[CLIP LIST]**.
- b. Press **[CREATE]**. The display will show the default CLIP ID.
- c. Press **[LOAD]** to accept the default CLIP ID.
OR

Manually enter an ID with a maximum of 8 characters from the ST400 numeric keypad, **OR** a PC keyboard, **OR** the Shotbox “QWERTY” keyboard.

NOTE: For numbers on the SHOTBOX keyboard, use bank keys **[0]-[9]**.

- d. Press **[LOAD]**.
The clip will be created with the entered CLIP ID.

If the selected CLIP ID already exists, a warning message will be displayed. To load the existing clip, press **[ENTER]**. Press **[ESC]** to exit without loading the existing clip.

21. CAPTURE

This function allows clips to be recorded on to the Video Server from a video source (SOURCE) such as a VTR. The SOURCE is connected to the VTR6 connector on the rear of the 2044CL-O.

Prior to performing a capture, press **[MENU]**.

Set the PREROLL value for the SOURCE VTR. Typical value is 5 seconds.

Set the RECORD DELAY value. This is the record latency of the video server. Typical value is 3 (frames).

Select the destination Video Server Channel. The destination channel may be any VTR except VTR6.

a. Press VTR **[6]** to initiate the Capture function.

b. Set an IN point on the SOURCE VTR.
Jog/Shuttle to the desired IN point. Press **[IN]**.
OR

Press **[SHIFT] + [IN]**. Manually enter the IN time on the numeric keypad. Press **[ENTER]**.

c. Set an OUT point on the SOURCE VTR.
Jog/Shuttle to the desired OUT point. Press **[OUT]**.
OR

Press **[SHIFT] + [OUT]**. Manually enter the OUT time on the numeric keypad. Press **[ENTER]**.

d. Press **[SHIFT] + [RECORD]**.
The display will prompt for a CLIP ID.
Manually enter a CLIP ID (maximum of 8 characters) using the numeric keypad, the Shotbox QWERTY keyboard, or PC keyboard.

Press **[ENTER]** to accept the entered CLIP ID.

The SOURCE VTR will preroll to its IN point, then play. The video server will start recording at the SOURCE's IN point and stop recording at the SOURCE's OUT point.

The created clip will be loaded on the destination channel.

22. VIEW SHOTKEY ASSIGNMENTS

ON THE SHOTBOX

- a. Press [VIEW]. The VIEW LED indicator will turn on.
- b. Select the desired BANK by pressing the appropriate bank key.
- c. Press and hold the desired Shotkey.
- d. The LCD display on the Shotkeys will show the current assignment of all 6 VTRs for the pressed Shotkey.
- e. Release the Shotkey when done viewing.
- f. Repeat steps a through e.

23. CREATE CUE POINT LABELS

Use LABELS mode to assign meaningful names to cue points. Rather than viewing cryptic CLIP IDs on the Shotkeys, LABELS provides a faster and easier method to select cue points.

If different parts of the same clip are assigned to many Shotkeys, LABELS allows a unique name to be assigned to each Shotkey.

ON THE ST400

- a. In Setup Menu, turn LABEL MODE on.
- b. Select cue point to label.
- c. Press the [LABEL] key.
- d. Manually enter a label, up to 8 characters in length, using the numeric keypad, ST420 Shotbox QWERTY keyboard, or PC keyboard.
- e. Press the [LOAD] shotkey on the Shotbox to assign the entered label to the selected cue point.
OR
[ENTER] on the ST400.
OR
[ENTER] on the PC keyboard.
OR
[NEXT CUE] or [LAST CUE].

NOTE: Labels are saved in non-volatile memory in the ST400, not in the Shotbox. They are not saved in the video server.

Reference . . .

24. SETUP MENU

Press [MENU]. The MENU indicator will turn on.
The display will show the following parameters with their current settings.

Turn the wheel to select a menu option.
Press the [CHANGE] softkey to modify the current setting.

Press the [EXIT] softkey to exit the Setup Menu.

<u>PARAMETER</u>	<u>DESCRIPTION</u>
WIND MODE	<p>Press Softkey to select: HOLD (fast wind is maintained only while key is depressed.) OR LATCH (fast wind is maintained after key is released.)</p> <p>Set the fast wind speed (3.9 to 23.7) by pressing the [SPD] softkey.</p>
RECORD MODE	<p>Press [MENU] to select the desired record mode: Lockout, Assemble, Crash (Full) or Insert.</p> <p><u>Only</u> in INSERT mode: Press the associated Softkey, located below the display, to toggle Video(V), Audio1(A1), Audio2(A2), Audio3(A3) on/off, Audio4 (A4) on/off.</p>
SLOMO	<p>Press the [TBAR] (or [WHEEL]) softkey to select the T-bar or wheel for slomo.</p> <p>For T-bar: The T-BAR has a speed range of 0 → 2x with a detent at 1x play speed OR a range of 0 → 1x (detent at 1x Play speed).</p> <p>Press [SPD-RNG] softkey to toggle between SLOMO speed ranges: 0 → 1x OR 0 → 2x.</p> <p>Press [BACK] softkey to return to SLOMO MENU.</p> <p>Press [ESC] to exit OR turn the Wheel to select another item.</p> <p>For Wheel: Press the [PRSET] softkey to toggle between UPDATE and STATIC modes.</p> <p>UPDATE: When exiting SLOMO mode, the last used speed is saved in the Preset Speed register.</p> <p>STATIC: The Preset Speed register is NOT updated when exiting SLOMO mode. It is only changed by [SHIFT] + [SLOMO] (PRESET SLOMO).</p> <p>Press [SPD-RNG] softkey to toggle between SLOMO speed ranges: 0 → 1x OR 0 → 2x.</p>

<u>PARAMETER</u>	<u>DESCRIPTION</u>
SYNC	Select the appropriate softkey to enable or disable the Reference Video input. [ON] [OFF]
RECORD KEY	Select single button or 2-button record: RECORD = [REC] Only OR RECORD= [REC] + [PLAY]
RECALL MODE	Press [NORMAL] or [REDIR] (redirect). REDIR- When one and only one clip is learned into a Cue Point, the Clip will be REDIRECTED to load on the currently selected VTR NORMAL- The cue point will load on the learned VTR.
PREROLL	Enter Preroll value.
RECORD DELAY	Enter delay value. (Used by CAPTURE function.)
GANG MODE	[PERM] Permanent Gang- The GANG can be created and undone only with the [GANG] softkey. [TEMP] Temporary Gang- Quickly create a GANG by pressing and holding a VTR key, then pressing other VTR keys. Quickly undo the GANG by pressing any VTR key. Video Reference must be connected for frame accurate playout of ganged channels.
STANDARD	Press [NTSC] or [PAL] to select the video standard for time calculations.
PROTOCOL	Select [ODETICS] or [BVW] . [ODETICS] Select Odetics to allow clip functionality: Load, Create, Recue, View available Clips. [BVW] Select BVW to control video server like a VTR. In this mode, the clip must have already been loaded.
TIMECODE	Select [NOT SUPPORTED] to have TC search on the GVG servers, or [SUPPORTED] for all other servers.

<u>PARAMETER</u>	<u>DESCRIPTION</u>
DESTINATION CHANNEL SELECT	Select [VTR1], [VTR2], [VTR3], [VTR4], [VTR5] or [VTR7] to be the destination (recorder) channel for Capture Function. [VTR6] cannot be selected.
PB ADDRESS	Select [VTR1], [VTR2], [VTR3], [VTR4], [VTR5] or [VTR6]. Assign Pbus Device Address to selected VTR by entering an address between 0 and 23. Or, press DEL to clear the Pbus Device Address.
PB SWITCHER	Select [GRASS VALLEY] or [SONY] Production Switcher. For Philips, use Grass Valley.
PBIO PARITY	Press [NONE], [ODD] or [EVEN] parity to match the Pbus setting on your Production Switcher.
CLEAR MEM	<p>[DFLTS] [CLR – LBL] [CLR – QS] [CLR-BNK] [BACK]</p> <p>DFLTS Set ST400 to factory defaults. Follow the prompts on the display. Press [YES] to continue or press [NO] to exit without changing ST400.</p> <p>CLR – BNK Clears all cue points in the selected bank. Follow the prompts on the display.</p> <p>CLR – QS Clears all cue points in all banks. Follow the prompts on the display.</p> <p>CLR – LBL Clears all labels associated with cue points. Does not clear cue points. Follow the prompts on the display.</p> <p>BACK Return to prior menu item.</p>

25. FUNCTION TABLE

Function	Key Press	Description
CUE TO OUT POINT	[CUE OUT]	If OUT point is marked, cue to the OUT point.
FFWD	[FFWD]	Press and HOLD to shuttle. Release key to stop. Set WIND Speed in MENU.
GOTO ENTERED TIME	[SHIFT] + [RECUE]	Search the VTR to the manually entered time. Use the ST400 numeric keypad. Press [ENTER] or [RECUE].
GANG SETUP	[GANG]	Individually press the VTR keys to be included in the gang. The LED above the key will turn on. Press the VTR key again to remove from gang. The LED above the key will turn off. Press [ESC] to exit. Upon exiting, all members of the gang will have their VTR LEDs turned on. The flashing LED shows which VTR is currently selected.
JOG	[JOG]	Select JOG mode and enable Wheel.
LAST CUE	[LAST]	Step to the previous Cue Point Location.
LOOP	[LOOP ENABLE]	Plays the currently loaded clip in a continuous loop.
NEXT CUE	[NEXT]	Step to the next Cue Point Location.
PREROLL	[PREROLL]	If an IN point is marked, preroll to the IN point using the PREROLL VALUE in the Setup Menu.
RECORD	[REC]	Places VTR into the Record mode selected by RECORD MODE in the SETUP MENU. Press [RECORD] or [RECORD] + [PLAY].
REWIND	[RWD]	Press and HOLD to shuttle. Release key to stop. Set WIND Speed in MENU.
SHUTTLE	[SHUTTLE]	Select SHUTTLE mode and enable Wheel.
SLOMO	[SLOMO]	Press [SLOMO] to slo-mo the VTR. Turn the Wheel (or move the T-Bar, if available) to change the play speed. Press [SLOMO] to STILL frame OR press any transport key to exit SLOMO.
SLO-MO SPEED PRESET	[SHIFT] + [SLOMO]	For WHEEL ONLY: Press [SHIFT] + [SLOMO] to preset the slo-mo speed. Turn the Wheel to select desired speed. Press [ESC] or any transport key to exit.

Function	Key Press	Description
STOP	[STOP]	Press once to STILL frame VTR. Press again to put VTR into STOP mode.
TIME MODE SELECT	[TIME MODE]	Press to toggle between Timecode (TC), VITC (VT) or Tape Timer (TM) display modes.
PLAY	[PLAY]	If an OUT point is marked, play to the OUT point and stop. If no OUT point is marked, play normally. If the CLIP ID ends with an '*', do loop play.
PLAY- SIMPLE	[SHIFT] + [PLAY]	Play normal.
RECUE	[RECUE]	If the IN point is marked, cue to the IN point. If IN point is not marked, cue to the beginning of the clip. (Under BVW protocol, no action occurs.)
PBIO ENABLE/ DISABLE	[PBIO]	PBIO LED is ON if PBIO is enabled. Toggle the key to temporarily disable all PBIO signals. The key blinks when a valid PBIO command is received from the Production Switcher.

26. SPECIFICATIONS

a. ST400

Power: 90 VAC to 265 VAC adapter supplied with IEC connector
APX Model #AP4108
+5v @ 4A, +12v @ 1.0A, -12V @ 0.6A

Size: [L" x W" x H"] 12 3/4" x 8" x 1 3/4" (front) 3 5/8" (rear)
[8 5/8" high to top of display]

Weight: 10 lbs.

Rear Panel Connectors:	VTR1, 2, 3, 4, 5,6	(All DB9F)
	GPI	(DBF25F)
	Power	(DB9M)
	SHOTBOX	(DB9F)
	PBIO	(DB9F)
	Keyboard	(6-pin mini DIN)
	Ref. Video In	(BNC)
	Ground	Threaded stud.

Display: Easy to read, back-lit LCD display

Jog/Shuttle Wheel: With mechanical detents

RS422 SERIAL CONNECTOR

9-Pin D-Type, Female (DB9F)

Pin #	1	Frame Ground	6	Receive Common
	2	Receive A ←	7	Receive B ←
	3	Transmit B →	8	Transmit A →
	4	Transmit Common	9	Frame Ground
	5	Spare		

POWER CONNECTOR

9-Pin D-Type, Female (DB9M)

Pin #	1	+5v DC	6	+5 VDC
	2	+5v DC	7	Ground
	3	Ground	8	Ground
	4	+12 VDC	9	Ground
	5	-12 VDC		

GPI IN/OUT CONNECTOR
26-Pin D-Type, Female (DB26F)

Pin #	OUT	IN/ Function	Pin #	OUT	IN/ Function
1	OUT	GPO 0 – No function	14	IN	LAST CUE
2	OUT	GPO 1 – No function	15	IN	RECALL CUE
3	OUT	GPO 2 – No function	16		No Connection
4	OUT	GPO 3 – No function	17		No Connection
5	OUT	GPO 4 – No function	18		Ground
6	OUT	GPO 5 – No function	19		+5V
7	OUT	GPO 6 – No function	20		+5V
8	OUT	GPO 7 – No function	21		No Connection
9		Ground	22		No Connection
10	IN	PLAY	23		No Connection
11	IN	STOP	24		No Connection
12	IN	RECUE	25		No Connection
13	IN	NEXT CUE	26		Ground

b. ST420 (SHOTBOX)

Power: 90 VAC to 265 VAC adapter supplied with IEC connector
AULT Model #SW300
+5v @ 3.5A, +12v @ 2A, -12v @ 0.8A

Size: [L" x W" x H"] 11.5" x 6 .5" x 1.75" (front) 3.5" (rear)

Weight: 4 lbs.

Rear Panel Connectors: Out (DB9F)
GPI (DBF15F)
Power (DB9M)
Aux (DB9F)

RS422 SERIAL CONNECTOR

9-Pin D-Type, Female

Pin #	1	Frame Ground	6	Transmit Common
	2	Transmit A →	7	Transmit B →
	3	Receive B ←	8	Receive A ←
	4	Receive Common	9	Frame Ground
	5	Spare		

POWER CONNECTOR

9-Pin D-Type, Male

Pin #	1	+5v DC	6	No Connection
	2	+5v DC	7	Ground
	3	Ground	8	Ground
	4	No Connection	9	Ground
	5	No Connection		

27. TROUBLESHOOTING

a. ST420 TROUBLESHOOTING

- 1) All Shotkeys are RED - No communication with the ST400.
- 2) All Shotkeys are DARK - No communication between the ST400 and the Video Server.
- 3) Set the ST420 version to match the ST400:

On the ST420 V4.02, V4.03, V4.12, V4.13”

- a) Press **[SHIFT] + [STOP] + [PLAY]**.
The key that displays the current version is RED.
- b) The ST420 displays:
“ST300/400 SELECT”
[ST300 V2.X]
[ST300 V3.X]
[ST400 2044CL-O]
[ST400 2044CL-L]
- c) Press the **[ST400 2044CL-O]** key for communication with the ST400.

On the ST420 V4.04, V4.14 and above:

- a) Press **[SHIFT] + [STOP] + [PLAY]**.
The key that displays the current versions is RED.
- b) The ST420 displays:
“ST300/400 SELECT”
[ST300 V2.X]
[ST300 V3.X]
[ST400 V4.X – V5.20]
[ST400 V5.30 and up]
- c) Press a key that corresponds to the version of the ST400 that you are using.

b. PBIO TROUBLESHOOTING

Press **[SHIFT] + [PBIO]**. The display will show PBIO DATA.

All Pbus commands received from the production switcher will be shown on the display. Communication errors due to parity mismatch or baud rate mismatch will be shown as “-“. If no command data is shown, then no commands are being received from the production switcher. Check the Production Switcher’s Pbus set. Also check the cabling between the Production Switcher and ST400.

Press **[SHIFT] + [PBIO]** to exit this test mode.

28. KEY LAYOUT

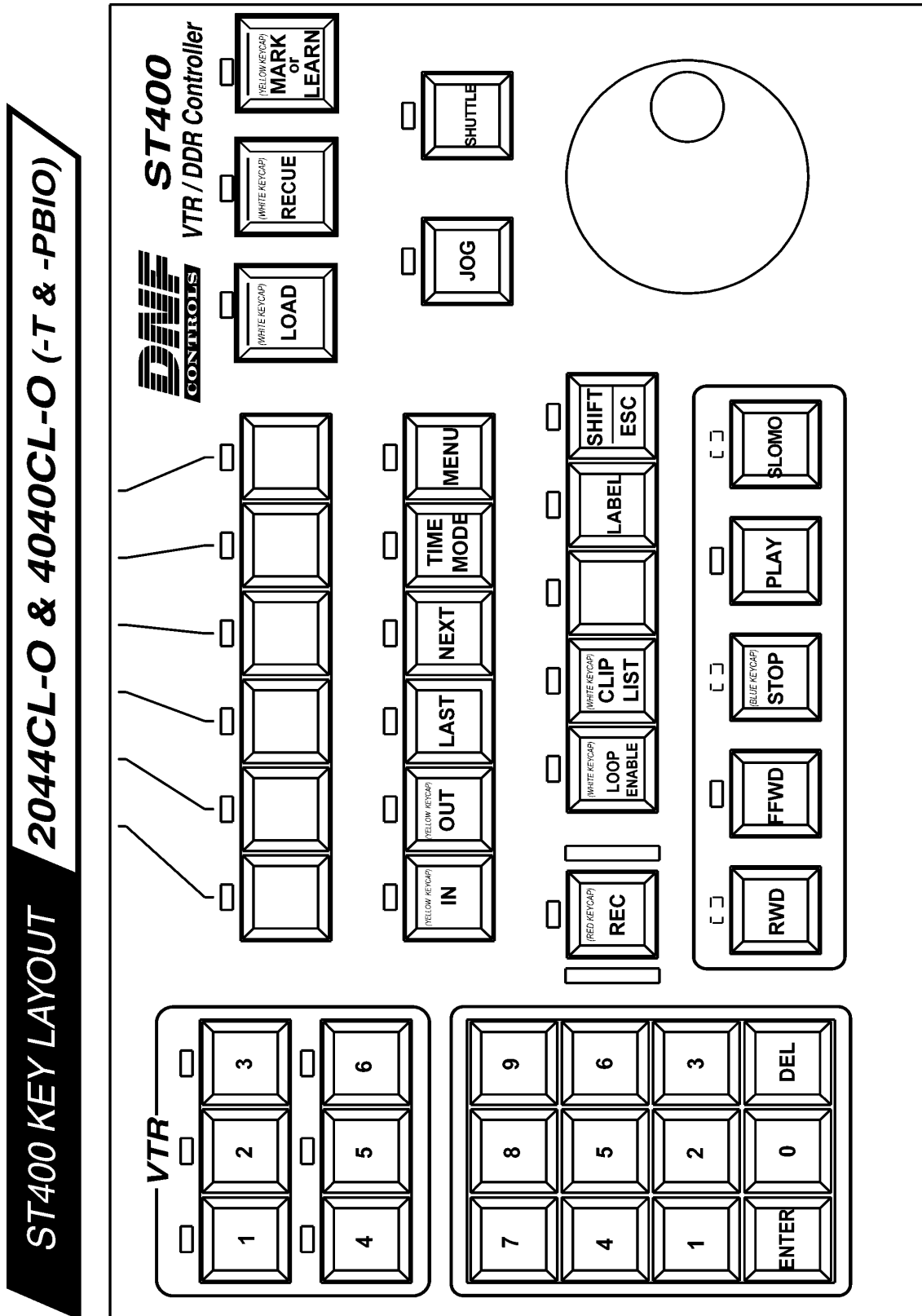

29. DNF CONTROLS LIMITED WARRANTY

DNF Controls warrants its product to be free from defects in material and workmanship for a period of one (1) year from the date of sale to the original purchaser from DNF Controls.

In order to enforce the rights under this warranty, the customer must first contact DNF's Customer Support Department to afford the opportunity of identifying and fixing the problem without sending the unit in for repair. If DNF's Customer Support Department cannot fix the problem, the customer will be issued a Returned Merchandise Authorization number (RMA). The customer will then ship the defective product prepaid to DNF Controls with the RMA number clearly indicated on the customer's shipping document. The merchandise is to be shipped to:

DNF Controls
12843 Foothill Blvd., Suite D
Sylmar, CA 91342
USA

Failure to obtain a proper RMA number prior to returning the product may result in the return not being accepted, or in a charge for the required repair.

DNF Controls, at its option, will repair or replace the defective unit. DNF Controls will return the unit prepaid to the customer. The method of shipment is at the discretion of DNF Controls, principally UPS Ground for shipments within the United States of America. Shipments to international customers will be sent via air. Should a customer require the product to be returned in a more expeditious manner, the return shipment will be billed to their freight account.

This warranty will be considered null and void if accident, misuse, abuse, improper line voltage, fire, water, lightning or other acts of God damaged the product. All repair parts are to be supplied by DNF Controls, either directly or through its authorized dealer network. Similarly, any repair work not performed by either DNF Controls or its authorized dealer may void the warranty.

After the warranty period has expired, DNF Controls offers repair services at prices listed in the DNF Controls Price List. DNF Controls reserves the right to refuse repair of any unit outside the warranty period that is deemed non-repairable.

DNF Controls shall not be liable for direct, indirect, incidental, consequential or other types of damage resulting from the use of the product.

###