



12843 Foothill Blvd.,
Suite D
Sylmar, CA 91342
818 898 3380 voice
818 898 3360 fax
www.dnfcontrols.com

Model 3000P-LTK

PLAYLIST PLAYOUT SYSTEM

Louth-Tektronix Protocol

USER MANUAL

Table of Contents

1.	REVISION HISTORY	3
2.	DESCRIPTION	4
	DEFINITIONS	4
3.	INSTALLATION	5
4.	VIDEO SERVER SETUP	6
5.	PLAYLIST FUNCTIONS	6
	A. LCD DISPLAY	6
	B. CREATE A PLAYLIST	6
	C. TO PLAY A SINGLE CLIP	7
	D. TO PLAY MULTIPLE CLIPS	7
	E. TO ABORT PLAYING A LIST OF CLIPS	7
	F. TO EDIT A PLAYLIST	7
6.	SETUP MENU	9
7.	SPECIFICATIONS	10
	RS422 SERIAL CONNECTOR	10
	POWER CONNECTOR	10
8.	DNF CONTROLS LIMITED WARRANTY	11

Manual Version..... 2.5 120704
Document ID..... 3000P-LTK User Manual.doc

1. REVISION HISTORY

100803	Rev. 2.2	Company header information revised.
112103	Rev. 2.3	Added DNF Controls Limited Warranty.
020204	Rev. 2.4	Reformatted. Added Transferring Cue List section.
120704	Rev. 2.5	Removed Transferring Cue List section.

2. DESCRIPTION

The PLAYLIST Option allows quick and easy creation, editing and playout of video clips using the CLIP ID functions available in the Louth-Tektronix protocol.

The user can remotely view the CLIP IDs that exist in the Video Server and enter them into the PLAYLIST. The ST300 maintains the PLAYLIST in non-volatile memory.

DEFINITIONS

Throughout this document VTR, DDR, VDR & Video Server will be referred to collectively as "Video Server."

Words surrounded by brackets, for example, [ENTER], are keys on the ST300.
[XXX] + [XXX] means hold the two keys down simultaneously. XXX = Key name.

3. INSTALLATION

- a. Plug one end of a 9-conductor, RS422 serial cable into the 9-pin connector (VTR1, VTR2, VTR3 or VTR4) on the rear of the ST300.
- b. Plug the other end of the cable into the 9-pin REMOTE connector on the Video Server.
- c. Plug the power supply into an outlet, 90 VAC to 240 VAC.
- d. Assign a Louth Port to the ST300 VTR connector.
 - 1) Press [MENU]. The display shows “VTR? Louth Address” “Enter 1-9”
 - 2) Press VTR[1], VTR[2], VTR[3] or VTR[4] to select a VTR.
 - 3) Assign a Louth Port for that VTR from 1-9 using the numeric keypad. To turn the port off, Enter “0.”
 - 4) Repeat steps 2-3 to assign Port numbers to all desired VTRs.
 - 5) Press [ESC] at anytime to exit the MENU.

Installation complete.

CONNECTION DIAGRAM

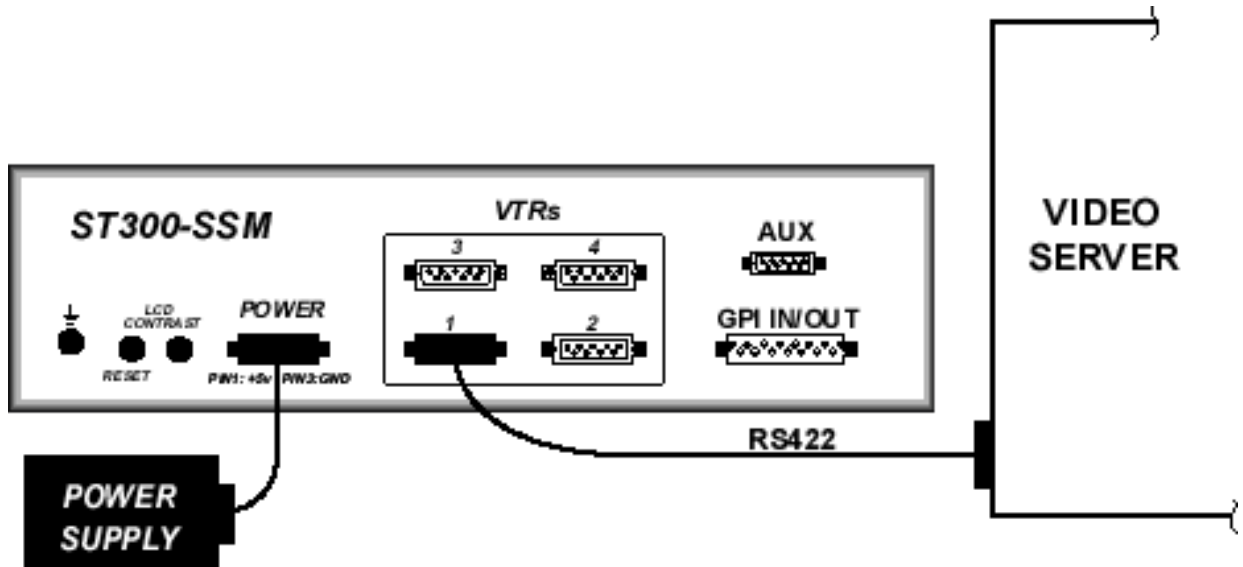

4. VIDEO SERVER SETUP

- a. Select Louth Automation communications protocol on the Video Server to be controlled.
- b. Assign a serial port through which the ST300 will control the VTR.
- c. Select remote mode on the VIDEO SERVER's control panel (if necessary).

5. PLAYLIST FUNCTIONS

a. LCD DISPLAY

The 4-line display shows the next clip to play, plus the next 2 clips in the PLAYLIST. The CLIP ID is displayed on the left, start time on the right. The currently selected clip is identified by an asterisk (*). The top line of the display shows the running tape time

PLAYLIST
TM 00:00:10:00
CLIP0002*00:00:03:00
CLIP0003 00:12:55:08
CLIP0004 00:21:10:18
^ ^
[CLIP ID Start Time]

b. CREATE A PLAYLIST

- 1) Press **[EDIT LIST]** to create a PLAYLIST. The EDIT LIST indicator comes on.
- 2) The screen displays "Use WHEEL or KEYPAD."
- 3) Turn the wheel clockwise to scroll forward through the list of available CLIP IDs in the video server.

Turn the wheel counterclockwise to scroll back through the last 10 CLIP IDs previously viewed.

OR

Use the numeric keypad to directly enter a numeric CLIP ID.

- 4) When the desired CLIP ID is displayed, press **[ENTER]** to add the clip to the PLAYLIST.
- 5) The screen now displays "Enter Start Time."
Enter the start time with the numeric keypad.
OR

Press **[ENTER]** to accept the default start time (00:00:00:00).

- 6) To add additional clips to the Playlist, repeat steps 3 through 5.
- 7) Press **[ESC]** to exit creating a Playlist. The EDIT LIST indicator goes out.

c. TO PLAY A SINGLE CLIP

- 1) Position the pointer (*) using the up arrow [^] or down arrow [v] to the clip to be played.
- 2) Press [**LOAD**] to load and cue the clip to the Start Time shown on the display. The LOAD indicator comes on.
- 3) Press [**PLAY**] to play the clip. The LOAD indicator goes out and the PLAY indicator comes on.
- 4) The Playlist automatically moves up in the display to the next clip in the PLAYLIST when [**PLAY**] is pressed.

d. TO PLAY MULTIPLE CLIPS

- 1) Position the pointer (*) using the up arrow [^] or down arrow [v] keys to the clip to be played.
- 2) Press [**LIST PLAY**]. The LIST PLAY indicator comes on.
- 3) The first clip selected will load and cue to the start time shown on the display.
- 4) The next clip will load into the preview position.
- 5) The list will play continuously until a break or the end of the list is reached.
- 6) The LIST PLAY indicator will turn off after the play sequence is completed.

e. TO ABORT PLAYING A LIST OF CLIPS

Press [**STOP**] to abort a playlist sequence.
[**STOP**] will not abort the sequence while editing the playlist.

f. TO EDIT A PLAYLIST

- 1) Press [**EDIT LIST**] to edit a PLAYLIST.
The EDIT LIST indicator comes on.

The display shows the current clip in the PLAYLIST with an asterisk (*).
If no CLIPS were entered, the display will show "PLAYLIST is empty."

To position the pointer (*) use the up arrow [^] or down arrow [v].

OR

Press [**LIST TOP**] to go the first CLIP in the PLAYLIST.

Press [**LIST END**] to go the last CLIP in the PLAYLIST.

- 2) The screen displays "Use WHEEL or KEYPAD."
Turn the wheel clockwise to scroll forward through the list of available CLIP IDs.

Turn the wheel counterclockwise to scroll back through the last 10 CLIP IDs previously viewed.
OR

Use the numeric keypad to directly enter a numeric CLIP ID.
- 3) When the desired CLIP ID is displayed, press **[ENTER]** to add the clip to the PLAYLIST.
- 4) The screen now displays "Enter Start Time."
Enter the start time with the numeric keypad.
OR

Press **[ENTER]** to accept the default start time (00:00:00:00).

Pressing **[ESC]** aborts adding a clip to the PLAYLIST.
- 5) To repeat entry of the current CLIP ID:
Press **[REPEAT ENTRY]**.
The screen now displays "Enter Start Time."
Enter the start time with the numeric keypad.
OR

Press **[ENTER]** to accept the default start time (00:00:00:00).
- 6) To delete an entry:
Position the pointer (*) using the up arrow [**^**] or down arrow [**v**] at the clip to be deleted.
Press **[DEL]**.
The screen displays "ENTER=Yes ESC=No"

Press **[ENTER]** to delete.

Press **[ESC]** to abort the delete.
After deleting an entry, the pointer (*) will be positioned at the item above the deleted entry.
- 7) To delete the entire PLAYLIST:
Press **[SHIFT] + [DELETE]**.
The screen displays "ARE YOU SURE?"

Press **[ENTER]** to delete the entire PLAYLIST.

Press **[ESC]** to abort the delete.
- 8) Press **[ESC]** to exit EDITING the PLAYLIST.
- 9) The **[LIST PLAY]** function will continue while editing a playlist.

6. SETUP MENU

- a. Press [**MENU**].
- b. Rotate the Wheel to access MENU options:
 - SET LOUTH ADDRESS

 - SET FACTORY DEFAULTS

 - CLEAR PLAYLIST
 - Press [**ENTER**] to delete all entries in the PLAYLIST.
 - Press [**DEL**] to abort clearing the PLAYLIST.

 - ABOUT Displays Model, Version and Date Code of unit

7. SPECIFICATIONS

Power:	90 VAC to 265 VAC adapter supplied with IEC connector	
Size:	(L" x W" x H") 12" x 6" x 1.5" (front) 3.0" (rear)	
Weight:	4 lbs.	
Rear Panel Connectors:	VTR1, VTR2, VTR3, VTR4 GPI Power Auxiliary	(All DB9F) (DBF15F) (DB9M) (DB9F)
Display:	Easy to read 2-line, back-lit LCD display (User adjustable contrast)	
Jog/Shuttle Wheel:	With mechanical detents	

RS422 SERIAL CONNECTOR

9-Pin D-Type, Female (DB9F)

Pin #	1	Frame Ground
	2	Receive A ←
	3	Transmit B →
	4	Transmit Common
	5	Spare
	6	Receive Common
	7	Receive B ←
	8	Transmit A →
	9	Frame Ground

POWER CONNECTOR

9-Pin D-Type, Male (DB9M)

Pin #	1	+5v DC
	2	+5v DC
	3	Ground
	4	+12 VDC
	5	-12 VDC
	6	+5 VDC
	7	Ground
	8	Ground
	9	Ground

8. DNF CONTROLS LIMITED WARRANTY

DNF Controls warrants its product to be free from defects in material and workmanship for a period of one (1) year from the date of sale to the original purchaser from DNF Controls.

In order to enforce the rights under this warranty, the customer must first contact DNF's Customer Support Department to afford the opportunity of identifying and fixing the problem without sending the unit in for repair. If DNF's Customer Support Department cannot fix the problem, the customer will be issued a Returned Merchandise Authorization number (RMA). The customer will then ship the defective product prepaid to DNF Controls with the RMA number clearly indicated on the customer's shipping document. The merchandise is to be shipped to:

DNF Controls
12843 Foothill Blvd., Suite D
Sylmar, CA 91342
USA

Failure to obtain a proper RMA number prior to returning the product may result in the return not being accepted, or in a charge for the required repair.

DNF Controls, at its option, will repair or replace the defective unit. DNF Controls will return the unit prepaid to the customer. The method of shipment is at the discretion of DNF Controls, principally UPS Ground for shipments within the United States of America. Shipments to international customers will be sent via air. Should a customer require the product to be returned in a more expeditious manner, the return shipment will be billed to their freight account.

This warranty will be considered null and void if accident, misuse, abuse, improper line voltage, fire, water, lightning or other acts of God damaged the product. All repair parts are to be supplied by DNF Controls, either directly or through its authorized dealer network. Similarly, any repair work not performed by either DNF Controls or its authorized dealer may void the warranty.

After the warranty period has expired, DNF Controls offers repair services at prices listed in the DNF Controls Price List. DNF Controls reserves the right to refuse repair of any unit outside the warranty period that is deemed non-repairable.

DNF Controls shall not be liable for direct, indirect, incidental, consequential or other types of damage resulting from the use of the product.

###