



12843 Foothill Blvd.,  
Suite D  
Sylmar, CA 91342  
818 898 3380 voice  
818 898 3360 fax  
[www.dnfcontrols.com](http://www.dnfcontrols.com)

# **Model No. 2034CL-N-PBIO (&2034CL-N-PBIO-T)**

**200 CLIP INSTANT ACCESS SYSTEM**

**FOR GRASS VALLEY GROUP *NATIVE* PROTOCOL  
WITH PERIPHERAL BUS INTERFACE OPTION**

## **User Manual**

# TABLE OF CONTENTS

<b>1. REVISION HISTORY</b>	<b>4</b>
<b><i>GETTING STARTED...</i></b>	<b>5</b>
<b>2. SYSTEM DESCRIPTION</b>	<b>5</b>
DEFINITIONS	6
<b>3. SYSTEM INSTALLATION</b>	<b>6</b>
A. ST300-S/SM, VTR/DDR CONTROLLER	6
B. ST420 SHOTBOX	6
C. PRODUCTION SWITCHER	7
<b>4. LOADING A CLIP</b>	<b>9</b>
<b>5. CAPTURE FUNCTION</b>	<b>9</b>
A. SETTING AN IN (OUT) POINT	9
B. CLEARING AN IN (OUT) POINT	9
C. GANGING CLIPS WITH PREVIOUSLY SET IN POINTS	9
D. GOTO TIME	10
<b>6. LEARN</b>	<b>10</b>
A. LEARN ON THE ST300	10
B. LEARNING IN POINTS, GANGED CLIPS	10
C. LEARN ON THE SHOTBOX	10
D. LEARN ON THE PRODUCTION SWITCHER	10
<b>7. RECALL</b>	<b>11</b>
A. RECALL ON THE ST300	11
B. RECALL ON THE SHOTBOX	11
C. RECALL ON THE PRODUCTION SWITCHER	11
<b>8. VIEW CONTENTS OF CUE POINTS ON THE SHOTBOX</b>	<b>11</b>
<b>9. TRIGGER</b>	<b>12</b>
GRASS VALLEY GROUP	12
SONY	12
<b><i>ADVANCED FEATURES...</i></b>	<b>13</b>
<b>10. LOOPING FUNCTIONS</b>	<b>13</b>
A. LOOP CLIP	13
B. SAVING CLIPS THAT AUTOMATICALLY LOOP	13
C. SAVING CLIPS THAT AUTOMATICALLY PLAY TO LOOP	14
<b>11. DUPLICATING A CLIP</b>	<b>14</b>
<b>12. TRIMMING A CLIP</b>	<b>15</b>
<b>13. RECORDING A NEW CLIP</b>	<b>15</b>
<b>14. VIEW CONTENT OF CUE POINTS ON THE ST300</b>	<b>16</b>
<b>15. TRANSFER CUELIST</b>	<b>16</b>
A. TRANSMIT CUE LIST FUNCTION	16
B. RECEIVE CUELIST FUNCTION	17
<b>16. SHOTBOX DISPLAY</b>	<b>17</b>
<b>17. SHOTBOX SHOTKEY MAPPING TO ST300 SHOTLIST LOCATIONS</b>	<b>18</b>
<b>18. SHOTBOX CONTROL SWITCHES</b>	<b>18</b>
<b>19. P-BUS REGISTER MAPPING TO CUE POINTS</b>	<b>18</b>

<b>20. SETUP MENU</b>	<b>19</b>
ST300 SETUP DEFAULTS	22
<b>21. FUNCTION TABLE</b>	<b>23</b>
<b>22. VIDEO SERVER SETUP</b>	<b>25</b>
A. CONFIGURING THE PROFILE FOR NATIVE MODE	25
B. OVERVIEW OF PROFILE CONNECTIONS	25
C. CONNECTION AND CHANNEL ASSIGNMENTS	26
<b>23. COMPLETING THE PROFILE CONNECTION</b>	<b>27</b>
A. PROFILE CONNECTION OPTIONS	27
B. DRIVE/DIRECTORY SELECTION	27
C. NAMING CONVENTIONS	28
<b>24. SPECIFICATIONS</b>	<b>29</b>
A. ST300	29
B. ST420 (SHOTBOX)	30
<b>25. TROUBLESHOOTING</b>	<b>31</b>
ST420 TROUBLESHOOTING	31
<b>26. KEY LAYOUT</b>	<b>32</b>
<b>27. DNF CONTROLS LIMITED WARRANTY</b>	<b>33</b>

**Manual Version ..... 1.3 110403**  
**Document No.....2034CL-N-PBIO User Manual**

# 1. REVISION HISTORY

081903	Rev. 1.1	Reformatted. Added Key Layout.
082503	Rev. 1.2	Clarified use of [MARK] & [LEARN] keys. Replaced Key Layout.
110403	Rev. 1.3	Added DNF Controls Limited Warranty. Updated Receive Cue List & Transmit Cue List Function description.

# *Getting Started . . .*

## **2. SYSTEM DESCRIPTION**

- \* NOW, production switchers can load and play video clips from PROFILE.
- \* Use the EMEM or SNAPSHOT Learn & Recall functions of the production switcher to load and play a video clip from a Recall or timeline.
- \* Use the Run and Trigger functions of the production switcher to Play, Stop or Recue the video clip. Instantly load a video clip at the press of a button.
- \* Instantly load a FILL clip and KEY clip at the press of ONE button, then play out both channels in sync.
- \* Control up to 3 video channels individually or ganged, including looping.

The 2034CL-N, 300 Clip Instant Access System consists of the ST300-SSM and the ST420 SHOTBOX. The ST300 and SHOTBOX share a common, non-volatile Cue Point memory in the ST300.

The Video Server is the Grass Valley Group PROFILE running Native Protocol.

The 10 banks of 30 switches each, on the SHOTBOX, provide instant access to 300 Clips.

Press [**LEARN**] on the SHOTBOX to learn the CLIP ID and current time of each clip on up to 3 video channels and the current GANG mode into the selected Shotkey on the SHOTBOX (cue Point on the ST300).

Press any Shotkey on the SHOTBOX to instantly recall the learned CLIP ID and cue to the learned Time on up to 3 video channels and setup the “learned” GANG mode.

With the Peripheral Bus Interface Option, the ST300 has 3 Peripheral Device Addresses, one for each VTR that it controls. This allows the production switcher to control any and all VTRs connected to the ST300.

Upon receipt of the LEARN command from the production switcher, the ST300 saves the CLIP IDs of the currently loaded clips, the current time of each clip, the VTRs they are loaded on and the current GANG mode, into the appropriate Cue Point.

When the RECALL command is received, the ST300 loads the “Learned” Clips onto the “Learned” VTRs, cues the Clip to the “Learned” time, then restores the “Learned” GANG mode.

The Trigger function on the production switcher puts the selected VTRs into Play, Stop, Recue or other available modes.

## DEFINITIONS

Throughout this document, the Grass Valley Group Profile will be referred to as the “Video Server.”

The ST300-S/SM as the ST300.

The ST420 as the SHOTBOX.

Words surrounded by brackets, for example, [ENTER], are keys on the ST300 or the SHOTBOX. [XXX] + [XXX] means hold the two keys down simultaneously.

Softkey refers to the multiple functions keys located directly below the display window.

## 3. SYSTEM INSTALLATION

### a. ST300-S/SM, VTR/DDR CONTROLLER

- 1) Plug one end of a 9-conductor, RS422 serial cable into the VTR 1 (2 or 3) connector on the rear of the ST300. Plug the other end of the cable into the REMOTE connector on the Video Server.
- 2) Connect the +5, +12, -12 VDC POWER SUPPLY into the POWER connector on the rear of the ST300. Plug the Power Supply into an outlet, 90 VAC - 240 VAC.

***Do NOT Hotplug!!!***

- 3) Check SETUP MENU prior to using the ST300 to confirm proper Record mode and other User settable modes. See CONFIGURING THE PROFILE FOR NATIVE MODE, Section 22.a.

### b. ST420 SHOTBOX

- 1) Plug one end of a 9-conductor, RS422 serial cable into the OUTPUT connector on the rear of the SHOTBOX. Plug the other end of the cable into the “AUX” connector on the ST300.
- 2) Connect the +5,VDC POWER SUPPLY into the POWER connector on the rear of the SHOTBOX. Plug the Power Supply into a wall outlet, 90 VAC - 240 VAC.

## c. PRODUCTION SWITCHER

- 1) Connect a standard cable (RS422, 9-pin serial cable) to the supplied turnaround adapter. Plug the turnaround adapter into the “VTR4” connector on the rear of the ST300. Connect the other end of the cable to the Peripheral Bus Connector on the production switcher. (Communication Format- 38.4K, N, 8,1)

The ST300 has 4 Peripheral Device Addresses, one for each VTR that it controls.

To set the Device Address for each VTR:

- 3) Press [MENU] on the ST300 and turn the Wheel until “PBIO Address” is displayed.
- 4) Press VTR[1], VTR[2] or VTR[3] to select a VTR.
- 5) Assign a Peripheral Device Address for that VTR, from 0 to 23, by entering the desired address using the numeric keypad. Address 24 or greater will turn PBIO off.
- 6) Select the next VTR and assign a Peripheral Device Address for it. Each VTR must have its own unique address.
- 7) To select a Production Switcher type (Default = Grass Valley Group).
  - a) Press [MENU] and turn the Wheel until “SWITCHER’ is displayed.
  - b) Press the Softkey to choose Sony or Grass Valley.
- 9) When done, press [ESC] to exit the MENU.
- 10) Configure the production switcher:
  - Enable the Peripheral Bus.
  - Enable the Peripheral Device Addresses assigned to the ST300.
  - Enable the appropriate Learn/Recall levels.
  - Enable the Timeline or Recall Trigger function.

Installation is complete.

## CONNECTION DIAGRAM

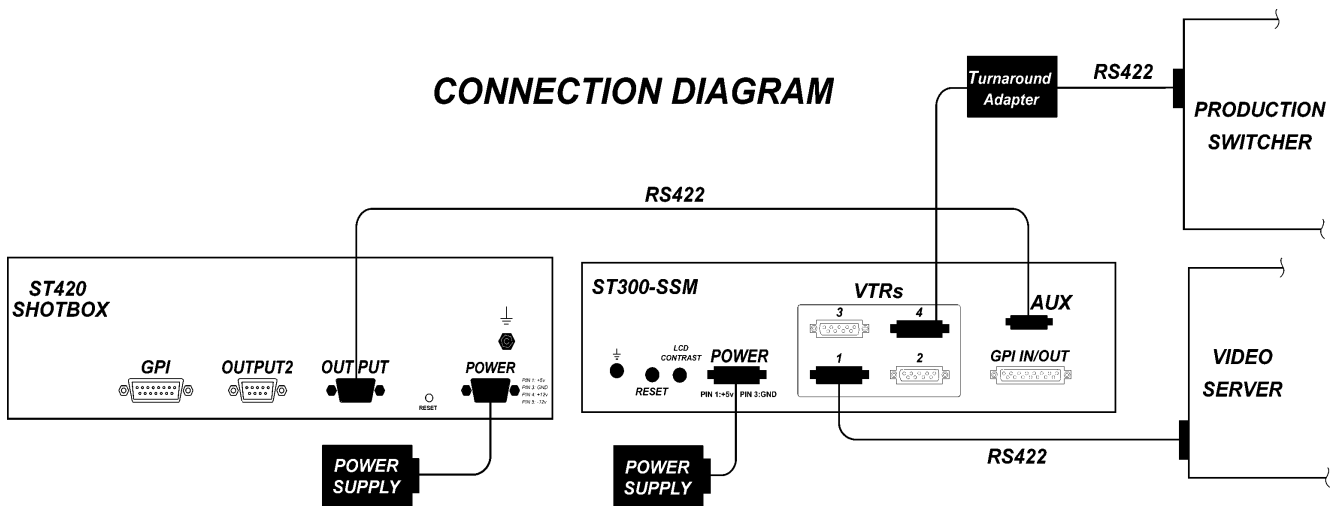

## 4. LOADING A CLIP

- a. Select a VTR by pressing VTR [1], VTR [2] or VTR [3].
- b. Press [CLIP LIST] to view the list of Clips that exist in the VIDEO SERVER. The CLIP LIST indicator comes on.

The display now shows:

Create New Clip? LOAD=OK      WHEEL=Next
---

- c. Turn the Wheel.  
The top line of the display will show:

XXXXXXXX      LOAD=OK ENTER ID:
------------------------------------

("XXXXXXXX" is the eight character CLIP ID)

Turn the Wheel clockwise to scroll forward, or counter-clockwise to scroll backward, through the list of available CLIP IDs.

**OR**

Enter the ID (if a clip has one) from the numeric keypad.

- d. Press [LOAD] to load the current CLIP ID shown on the top line of the display.
- e. Locate the clip to the desired IN time.

## 5. CAPTURE FUNCTION

### a. SETTING AN IN (OUT) POINT

- 1) Locate the clip to the desired IN (OUT) time.
- 2) Press [IN] ([OUT]).  
The IN (OUT) indicator comes on.

### b. CLEARING AN IN (OUT) POINT

Press and hold [DEL], then press and release [IN] ([OUT]).  
The IN (OUT) indicator goes out.

### c. GANGING CLIPS WITH PREVIOUSLY SET IN POINTS

If a gang is established with the master having an IN point, the gang relationship will be relative to the master IN point and all slave IN points will be overwritten.

d. **GOTO TIME**

- 1) Press [SHIFT] + [RECUE] to enter a search time.
- 2) Enter the desired time using the numeric keypad.
- 3) Press [RECUE].

**OR**

Press [ENTER] to GOTO the selected time.

**6. LEARN**

**NOTE:** The ST300 and SHOTBOX share common memory in the ST300. If a LEARN is done on the SHOTBOX, it doesn't need to be LEARNed on the ST300.

a. **LEARN ON THE ST300**

- 1) Select a VTR by pressing VTR [1], VTR [2] or VTR [3].
- 2) LOAD a Clip. If LEARNING a Gang, load all clips and set the Gang.
- 3) Select the desired Cue Point by pressing [NEXT CUE], [LAST CUE] or by manually entering the Cue Point using the numeric keypad.

The selected Cue Point number is shown on the bottom line of the display.

- 4) Press [SHIFT] + [MARK] to initiate the LEARN of the current configuration.

The display shows:

Select VTR: Learn - OK, ESC-Cancel
---------------------------------------

- 5) Press VTR [2] or VTR [3] to select the VTRs.
- 6) Press [MARK] and the ST300 will: LEARN (save) the Cue Point, CLIP IDs, IN and OUT Times, Current Directory and Ganged VTRs.

b. **LEARNING IN POINTS, GANGED CLIPS**

If the master has no IN point, the current location of each clip in the gang will be learned as IN points, IF the slaves have IN points, the slaved in points will be overwritten.

c. **LEARN ON THE SHOTBOX**

- 1) Press [LEARN].
- 2) Select Bank and press Shotkey

d. **LEARN ON THE PRODUCTION SWITCHER**

- 1) Select and enable the Peripheral Device Addresses for the ST300.
- 2) Do a LEARN to the desired REGISTER.  
The ST300 will: LEARN (save) the VTR number, loaded CLIP ID, and current time into the REGISTER number in the ST300.

## **7. RECALL**

### **a. RECALL ON THE ST300**

- 1) Select the desired Cue Point by pressing [**NEXT CUE**], [**LAST CUE**] or by manually entering the Cue Point using the numeric keypad.

The selected Cue Point number is shown on the bottom line of the display.

- 2) Press [**LOAD**] on the ST300.

The ST300 will automatically load the Learned clips on the Learned VTRs, cue the clips to the Learned time, then set the Learned GANG mode.

### **b. RECALL ON THE SHOTBOX**

- 1) Select the desired BANK, pressing BANK 0-9.
- 2) Select the desired Shotkey and press.

### **c. RECALL ON THE PRODUCTION SWITCHER**

- 1) RECALL the desired REGISTER NUMBER.
- 2) The ST300 will automatically load the Learned clips on the Learned VTRs, cue the clips to the Learned time, then set the Learned GANG mode.

## **8. VIEW CONTENTS OF CUE POINTS ON THE SHOTBOX**

- a. Press and hold [**VIEW**].

- b. Select the desired bank key, then the desired switch key.  
The display will show assignments for all three VTRs in either the first 4 or last 4 buttons on the first row of the display keys.

## 9. TRIGGER

The operator fires a trigger using either the Timeline or Run function on the production switcher. The ST300 puts the Video Server into the following modes based upon the trigger value:

### GRASS VALLEY GROUP

<u>Trigger Value</u>	<u>Mode</u>
0	Play
1	Recue to beginning of clip
2	Slo-mo using ST300 Preset Speed
3	Reverse Play
4	Still Frame
5	LoopPlay
6 or greater	Play

### SONY

<u>Trigger Value</u>	<u>Mode</u>
0	Recue to beginning of clipPlay
1	Play
2	Slo-mo using ST300 Preset Speed
3	Reverse Play
4	Still Frame
5	LoopPlay
6 or greater	Play

To control more than one VTR, enable the Peripheral Device Address for the required VTRs. The Trigger will be sent to the enabled devices.

**OR**

GANG the required VTRs on the ST300. See FUNCTION TABLE, Section 21, for GANG instructions. Enable the Peripheral Device Address for one of the GANGED VTRs. The Trigger will be sent to the enabled VTR. The other VTRs in the GANG will perform the same action.

## *Advanced Features . . .*

### **10. LOOPING FUNCTIONS**

Loop: Play from the IN point to the OUT point continuously.  
Play to Loop: Played from the beginning of clip to the OUT point of the clip, then, playback continues at the IN point of the clip, then, the clip plays in a continuous loop from the IN point to the OUT point.

#### **a. LOOP CLIP**

- 1) Press [**LOOP ENABLE**] after a clip is loaded to place any clip in loop mode. To loop clips in GANG mode, the Master Clip should be loaded in loop mode. All the clips in the Gang will loop when [**PLAY**] is pressed.

**NOTE:** Clips will now loop from the IN point to the **END** of the clip or the OUT point (if set).

- 2) Press [**LOOP ENABLE**] + [**SHIFT**] to Play To Loop.

#### **b. SAVING CLIPS THAT AUTOMATICALLY LOOP**

To automatically Loop a clip each time it is loaded, **DUPLICATE** the clip and assign the suffix “\*” to the CLIP ID.

On the ST300: Press [**ENTER**] + [**0**] to add a “\*” at the end of the clip name.

For example, a clip named TEASER would be named TEASER\* to loop each time it is loaded.

## c. **SAVING CLIPS THAT AUTOMATICALLY PLAY TO LOOP**

- 1) To automatically Play to Loop a clip each time it is loaded, **DUPLICATE** the clip and assign the suffix “#” to the **CLIP ID**.

On the ST300: Press **[ENTER]** + **[1]** to add a “#” at the end of the clip name.

- 2) Locate the desired **IN**, then **OUT** point.  
Press **[IN]**(**[OUT]**) to set the **IN(OUT)** point. The **IN(OUT)** indicator will turn on.
- 3) Select the desired Cue Point by pressing **[NEXT CUE]**, **[LAST CUE]** or by manually entering the Cue Point using the numeric keypad.

The selected Cue Point number is shown on the bottom line of the display.

- 4) Press **[SHIFT]** + **[LEARN]** to initiate the **LEARN** of the current configuration.

The display shows:

Select VTR: Learn - OK, ESC-Cancel
---------------------------------------

- 5) Press **VTR [1]**, **VTR [2]** or **VTR [3]** to select the **VTRs**.
- 6) Press **[LEARN]** and the ST300 will: **LEARN** (save) the Cue Point, **CLIP IDs**, **IN** and **OUT** Times, **Current Directory** and **Ganged VTRs**.

For example, a clip named “Game” would be named **Games#** to Play to Loop each time it is loaded.

## 11. **DUPLICATING A CLIP**

- a. To save a copy of a clip, first **LOAD** the clip.
- b. Set the **IN** and **OUT** points at the head and tail of the clip.  
Press **[SHIFT]** + **[CLIP LIST]**.

The display will show:

“Save Trimmed Clip?”
LOAD =            Yes    Wheel
= Next

- c. Press **[LOAD]**.

Enter a numeric **CLIP ID** using the numeric keypad on the ST300.

**OR**

An alphanumeric **CLIP ID** using the **SHOTBOX** “qwerty” keyboard, using **NAMING CONVENTIONS**, Section 23.c.

To add looping functions to the duplicated clips, see **LOOPING FUNCTIONS**, Section 10, for more information.

- d. Press **[LOAD]** to save.  
**OR**

Press **[ESC]** to abort without saving.

## 12. TRIMMING A CLIP

- a. To make a sub-clip, first LOAD the clip.
- b. Locate the desired IN, then OUT point.  
Press **[IN]**(**[OUT]**) to set the IN(OUT) point. The IN(OUT) indicator will turn on.

- c. Press **[SHIFT]** + **[CLIP LIST]**. The display will show:

“Save Trimmed Clip?” LOAD = Yes    Wheel = Next
--

- d. Press **[LOAD]**.

- e. After pressing **[LOAD]**, the display shows: “Manually enter ID”

Enter a numeric CLIP ID using the numeric keypad on the ST300.

**OR**

An alphanumeric CLIP ID using the SHOTBOX “qwerty” keyboard, using NAMING CONVENTIONS, Section 23.c.

- f. Press **[LOAD]** to save the trimmed clip.

**OR**

Press **[ESC]** to abort without saving.

## 13. RECORDING A NEW CLIP

- a. To make a new clip and insert video from either another Profile channel or an external source, first press **[CLIP LIST]**. The Clip List indicator comes on.

- b. Since there is no clip loaded, the display now shows:

Create New Clip? LOAD= OK    WHEEL= Next
---

- c. Press **[LOAD]**.

- d. After pressing **[LOAD]**, the display shows: “Manually enter ID”

Enter a numeric CLIP ID using the numeric keypad on the ST300.

**OR**

An alphanumeric CLIP ID using the SHOTBOX “qwerty” keyboard, using NAMING CONVENTIONS, Section 23.c.

- e. Press **[LOAD]** to save the new CLIP ID.

**OR**

Press **[ESC]** to abort without saving.

- f. Recall the Clip and then start the video that will be inserted.

- g. Press **[RECORD]**.

- h. Press **[STOP]** when finished.

## 14. VIEW CONTENT OF CUE POINTS ON THE ST300

- a. Select the VTR to examine the contents of a Cue Point by pressing [1], [2] or [3].
- b. Press [NEXT CUE] or [LAST CUE] to step through the Cue Points  
**OR**

Enter a 1-, 2- or 3-digit number on the numeric keypad, followed by [ENTER].

The contents of the selected Cue Point are shown on the bottom line of the display.

## 15. TRANSFER CUELIST

The TRANSMIT CUELIST function allows you to transmit your list of Cue Points to a PC, using the provided utility software on the PC, or to another ST300. Transfer to a PC requires OpSuite 3.0 software, which runs on a Windows-based computer. Contact DNF Controls for more information.

### a. TRANSMIT CUE LIST FUNCTION

#### 1) TO TRANSMIT CUE POINTS TO THE ST300

- a) Connect the VTR4 connector on the rear of the ST300 to the VTR4 connector of the receiving ST300 using an RS422 9-pin cable with TX and RX lines crossed.  
(A “turnaround” cable)
- b) Press [MENU] and scroll the Wheel to “Transmit CUE List?  
YES=Enter, Exit=ESC”
- c) Press [ENTER] to start transmitting.  
The Display shows “Waiting to transmit” on the first line.
- d) When the Receiver is ready, transfer starts automatically.  
The Display now shows “Transmitting cuelist.”
- e) After the transfer is over, the display shows “Transfer is over” for one second and then shows “Waiting to transmit” again.
- f) Connect another ST300 to transmit the list again.  
**OR**

Press [ESC] twice to exit the MENU mode.

#### 2) TO TRANSMIT CUE POINTS TO THE PC

- a) Connect the VTR4 connector on the back of the ST300 to one of the COM ports on the PC using a RS422 to RS232 adapter.
- b) Repeat steps b-f of the TRANSMIT CUE POINTS to the ST300 section.

The RECEIVE CUELIST function allows you to receive your list of Cue Points from a PC or from another ST300.

## b. RECEIVE CUELIST FUNCTION

The RECEIVE CUE LIST function allows you to receive your list of Cue Points from a PC or from another ST300. Transfer to a PC requires OpSuite 3.0 software, which runs on a Windows-based computer. Contact DNF Controls for more information.

### 1) TO RECEIVE CUE POINTS FROM THE ST300

- a) Connect the VTR4 connector on the back of the ST300 from the VTR4 connector of the transmitting ST300 using RS422 9-pin cable with TX and RX lines crossed.  
(A “Turnaround” Cable)
- b) Press [MENU] and scroll the Wheel to “Receive CUE List?  
YES=Enter, Exit=ESC”
- c) Press [ENTER] to start receiving.  
The Display shows “Waiting to receive” on the first line.
- d) When the Transmitter is ready, transfer starts automatically.  
The Display now shows “Receiving cuelist.”
- e) After the transfer is over the display shows “Done-Success! Press any key...”
- f) Press any key. The display shows “Receive cuelist?” message.
- g) Press [ESC] to exit the MENU mode.

### 2) TO RECEIVE CUE POINTS FROM THE PC

- a) Connect the VTR4 connector on the back of the ST300 to one of the COM ports on the PC using RS422 to RS232 adapter.
- b) Repeat steps b-g of the RECEIVE CUE POINTS from the ST300 section.

## 16. SHOTBOX DISPLAY

- a. Press [VIEW]. The VIEW indicator comes on.
- b. Press the desired switch to see the content.
- c. The switch turns RED and the content (CLIP ID) of the corresponding Cue Point is displayed on a virtual display.

For Example:

<b>VTR 1</b> <b>Clip 23</b>	<b>VTR 2</b> <b>Clip 13</b>	<b>VTR 3</b> <b>Clip 77</b>	<b>VTR 4</b> <b>No Assignment</b>
--------------------------------	--------------------------------	--------------------------------	--------------------------------------

**NOTE:** All the remaining switches are not illuminated.

- d. Release the keys to return to normal operation.

## 17. SHOTBOX SHOTKEY MAPPING TO ST300 SHOTLIST LOCATIONS

The SWITCHES on the SHOTBOX access the SHOTLIST locations as follows:

BANK 0, SWITCHES 1 → 30 access SHOTLIST locations 001 → 030.  
BANK 1, SWITCHES 1 → 30 access SHOTLIST locations 101 → 130.  
BANK 2, SWITCHES 1 → 30 access SHOTLIST locations 201 → 230.  
BANK 3, SWITCHES 1 → 30 access SHOTLIST locations 301 → 330.  
BANK 4, SWITCHES 1 → 50 access SHOTLIST locations 401 → 430.  
BANK 5, SWITCHES 1 → 30 access SHOTLIST locations 501 → 530.  
BANK 6, SWITCHES 1 → 30 access SHOTLIST locations 601 → 630.  
BANK 7, SWITCHES 1 → 30 access SHOTLIST locations 701 → 730.  
BANK 8, SWITCHES 1 → 30 access SHOTLIST locations 801 → 830.  
BANK 9, SWITCHES 1 → 30 access SHOTLIST locations 901 → 930.

## 18. SHOTBOX CONTROL SWITCHES

- a. [PLAY]: Plays out the selected clip.
- b. [RECUE]: Returns to the beginning of the clip.
- c. [STOP]: Stops playout of the clip.

The CONTROL Switch indicators show the real-time status of the Video Server.

## 19. P-BUS REGISTER MAPPING TO CUE POINTS

EMEM 1 > 30 access Cue Points 001 – 030  
EMEM 31 > 60 access Cue Points 101 – 130  
EMEM 61 > 90 access Cue Points 201 – 230  
EMEM 91 > 99 access Cue Points 301 – 309

**NOTE:** Cue Point 0 can be learned on the ST300 ONLY and can be recalled by EMEM 000. It cannot be recalled from the SHOTBOX.

# Reference . . .

## 20. SETUP MENU

Press [MENU]. The MENU indicator will turn on.

Turn the Wheel to select item to change.

Press [MENU] **OR** use the Softkeys to change the desired mode for that option.

Turn the Wheel at anytime to select another item.

Press [ESC] at anytime to exit SETUP MENU. The MENU indicator will turn off.

**IMPORTANT NOTE:** Please set the following MENU items during initial installation.

ST300 Setup: Clear Mem; Set Defaults

ST300 Config: Select Directory

<u>MENU MODES</u>	<u>(Turning Wheel Clockwise)</u>				
<b>DISPLAY SOFTWARE VERSION</b>	The version number and date for the currently installed software is displayed. For example: <table border="1" style="display: inline-table; vertical-align: middle;"> <tr> <td>2034CL-N-PBIO</td> <td>V3.0</td> </tr> <tr> <td></td> <td>011400</td> </tr> </table>	2034CL-N-PBIO	V3.0		011400
2034CL-N-PBIO	V3.0				
	011400				
<b>RECORD MODE</b>	Press Softkey to select the desired mode: Lockout or Crash (Full).				
<b>CHANNEL CONNECTOR ASSIGNMENT</b>	Press VTR key for CH (Channel) and CN (Connector) assignment.				
<b>RECORD LOOP TIME</b>	Press VTR keys for Record Loop Length. Then, enter HH:MM:SS:FF.				
<b>RECORD</b>	Press Softkey to select single button or 2-button record. RECORD = [REC] Only <b>OR</b> [REC] + [PLAY]				
<b>RECALL MODE</b>	Press Normal or Redirect (Redir). If [ <b>REDIR</b> ] is on: The Clip will be REDIRECTED to load on the currently selected VTR. If [ <b>NORMAL</b> ] is on: The Clip will be loaded on the VTR it is LEARNED into.				
<b>LEARN MODE</b>	In normal mode, LEARN the IN/Current time and OUT points, as well as any gang information.  In CLR_LRN mode, the IN and OUT points are cleared after the LEARN is done. This is used to set multiple Cue Points with individual IN and OUT points in the <b>SAME</b> video clip.				

<b>MARK-Q</b>	Press Softkey to: Enable ADVANCE to next Cue Point, when [ <b>MARK</b> ] is pressed. <b>OR</b> Maintain CURRENT Cue Point when [ <b>MARK</b> ] is pressed.				
<b>TAPE TIME</b>	NDF = non-drop frame. DF = drop frame.				
<b>STOP MODE</b>	PB = while playing a clip, when [ <b>STOP</b> ] is pressed, the Profile freezes on last good video.  PB/EE = When [ <b>STOP</b> ] is pressed the first time, the Profile freezes on last good video. When [ <b>STOP</b> ] is pressed a second time, video out is switched to video in.				
<b>WIND MODE</b>	Press Softkey to select: HOLD (fast wind is maintained only while key is depressed). <b>OR</b> LATCH (fast wind is initiated and maintained with momentary key press). Select fast wind speed (04X, etc.) by pressing Softkey.				
<b>SLOMO</b>	<table border="1" style="width: 100%; border-collapse: collapse;"> <tr> <td style="width: 50%; vertical-align: top;">ST300 display shows: (Non T-Bar Version)</td> <td style="width: 50%; text-align: center; vertical-align: top;"> SLOMO with:                      WHEEL  SpdRange                              Preset    <b>Prset</b> </td> </tr> <tr> <td style="vertical-align: top;">ST300 display shows: (T-Bar Version)</td> <td style="text-align: center; vertical-align: top;"> SLOMO with:                      TBAR  Wheel </td> </tr> </table> <p><b>NOTE</b> - The T-BAR has a fixed speed range of 0 → +300 with a detent at +100% play speed.</p> <p><b>For Wheel only:</b> Press Softkey [<b>SPDRANGE</b>] to select SLOMO speed ranges: Press Softkey to select: 0 → +300 <b>OR</b> -100 → +300.</p> <p>Press Softkey [<b>BACK</b>] to return to SLOMO MENU. Press [<b>ESC</b>] to exit <b>OR</b> turn the Wheel to select another item.</p> <p><b>For Wheel only:</b> Press Softkey [<b>PRESET</b>] to select the SLOMO Preset Speed Mode.</p> <p>Press Softkey [<b>UPDATE</b>]. When exiting SLOMO mode, the last used speed is saved in the Preset Speed register.</p> <p>Press Softkey [<b>STATIC</b>]. The Preset Speed register is NOT updated when exiting SLOMO mode. It is only changed by [<b>SHIFT</b>] + [<b>SLOMO</b>] (PRESET SLOMO).</p>	ST300 display shows: (Non T-Bar Version)	SLOMO with:                      WHEEL SpdRange                              Preset  <b>Prset</b>	ST300 display shows: (T-Bar Version)	SLOMO with:                      TBAR Wheel
ST300 display shows: (Non T-Bar Version)	SLOMO with:                      WHEEL SpdRange                              Preset  <b>Prset</b>				
ST300 display shows: (T-Bar Version)	SLOMO with:                      TBAR Wheel				
<b>MAX SHUTTLE SPEED</b>	Press Softkey to select maximum shuttle speed of the Profile.				
<b>PBIO ADDRESS</b>	Press VTR key to assign PBIO address.				

<b>SWITCHER TYPE</b>	Select switcher type. GVG = Grass Valley Group (default) or Sony. For Phillips DD35 with PBus, use GVG.
<b>PARITY</b>	Select ODD, EVEN or NONE. This is the parity sent via the Peripheral Bus to the ST300.
<b>DATA PORT</b>	Select the VTR Connector (1-4) through which the Cuelist may be transmitted or received.
<b>TRANSMIT CUELIST</b>	Transmits Cuelist to another ST300 or to a PC.
<b>RECEIVE CUELIST</b>	Receives Cuelist from another ST300 or a PC.
<b>SET TO PROFILE MODE</b>	Press Softkey [ <b>YES</b> ] to set ST300 to parameters currently stored in the Profile.
<b>UNASSIGNED PORT OPTION</b>	Recovers Profile resources which have been opened by another device. Press any key to allow the ST300 to report any unassigned resources. When prompted, "Press any key for unassigned resources."
<b>AUTO ALIGNMENT</b>	Option will automatically realign slaves <u>which are not on the same connector</u> as the master. This automatic realignment will occur upon pressing stop or after one second has elapsed while still. The second, delayed realignment will occur only in Shuttle, Slomo and Jog. (Supported ONLY in units with –a option)
<b>ST300 SETUP</b>	Press Softkey beneath ClearMem to clear all Cue Points to 00:00:00:00.  Press Softkey [ <b>YES</b> ] when asked "Are You Sure?" Press Softkey beneath SetDefault to set ST300 to default settings. Press Softkey [ <b>YES</b> ] to save.
<b>ST300 CONFIG</b>	Press Softkey [ <b>DRIVE</b> ], then press Softkeys to save the default drive or turn the Wheel to change the drive. Press Softkey [ <b>ENTER</b> ] to return to the ST300 CONFIG screen.  Press Softkey [ <b>DIRECTORY</b> ] to save the default directory or turn the Wheel to change the directory. Press Softkey [ <b>ENTER</b> ] to save the selected directory and return to the ST300 CONFIG screen  <b>NOTE:</b> Select default when first setting up the system or when eeproms are upgraded.

## ST300 SETUP DEFAULTS

<b>RECORD</b>	Lockout
<b>CHANNEL, CONNECTOR ASSIGNMENT</b>	CN1 for all. CHA, CHB, CHC, CHD respectively.
<b>RECORD</b>	RECORD = [REC] Only
<b>RECALL MODE</b>	Normal
<b>LEARN MODE</b>	Normal mode
<b>MARK-Q</b>	CURRENT Cue Point
<b>TAPE TIME</b>	NDF
<b>STOP MODE</b>	PB
<b>WIND MODE</b>	LATCH
<b>SWITCHER TYPE</b>	GVG
<b>PARITY</b>	ODD
<b>SLOMO with</b>	Wheel
<b>MAX SHUTTLE</b>	8 X
<b>DATA PORT</b>	CN3
<b>AUTO ALIGNMENT</b>	OFF

**NOTE:** The directory chosen in the MENU will be the directory selected upon reset. If the Profile's working directory is changed by other programs, when the ST300 starts it will change to the directory last chosen from the menu.

When installing an upgrade eeprom:  
     Clear the Cue Point memory  
     Set factory defaults  
     Set the directory

Then, reenter the CLIP IDs at the appropriate Cue Points or download them from a PC to which the list has been previously saved, using the Transfer Utility or Operator's Suite.

Also, enter into the MENU any changes from the default settings. Failure to follow this procedure may lead to corruption of the Clips and unpredictable operation.

## 21. FUNCTION TABLE

Function	Key Press	Description
GOTO ENTERED TIME	[SHIFT] + [RECUE]	Search the VTR to the manually entered time.  Use the ST300 numeric keypad. Press [ENTER] OR [RECUE].
GANG	[SHIFT] + [VTR #1] OR [SHIFT] + [VTR #2] OR [SHIFT] + [VTR #3]	[SHIFT] + [ANY VTR KEY] gang enable mode.  Then, one at a time, press the VTR keys to be included in the gang. The LED above the key will turn on.  Press the VTR key again to remove from gang, the LED above the key will turn off.  Press [ESC] to exit and save the gang.  The VTR LEDs that are on show the gang.  The flashing LED shows which VTR is currently selected (and is monitoring Time Code on the display).
FFWD	[FFWD]	Press and HOLD to shuttle. Release key to stop. Set WIND Speed in MENU.
JOG	[JOG]	Select JOG mode and enable Wheel.
LAST CUE	[LAST CUE]	Step to the previous Cue Point Location.
NEXT CUE	[NEXT CUE]	Step to the next Cue Point Location.
RECORD	[REC]	Places VTR into the Record mode selected by RECORD MODE in the SETUP MENU. Press [RECORD] OR [RECORD] + [PLAY].
REWIND	[RWD]	Press and HOLD to shuttle. Release key to stop. Set WIND Speed in MENU.
SHUTTLE	[SHUTTLE]	Select SHUTTLE mode and enable Wheel.
SAVE TRIMMED CLIP	[SHIFT] + [CLIP LIST]	Save Clip from the IN to the OUT point.
DISPLAY CURRENT DIRECTORY	[SHIFT] + [NEXT CUE]	Displays the Current Directory.
DISPLAY DIRECTORY CURRENT CUE POINT IS SAVED IN	[SHIFT] + [NEXT CUE] OR [SHIFT] + [LAST CUE]	Displays the directory in which the clips in the CURRENT Cue Point are saved.

DISPLAY DURATION OF CLIP and WHICH CLIP IS LOADED	[SHIFT] + [LOAD]	Display duration of currently loaded clip and which clip is loaded.
PRESET SLOMO SPEED	[SHIFT] + [SLOMO]	Turn Wheel to preset slo-mo speed.
SLOMO	[SLOMO]	Press [SLOMO] to slo-mo the VTR. Turn the Wheel (or move the T-Bar, if available) to change the play speed.  Press [SLOMO] to STILL frame. <b>OR</b> Press any transport key to exit SLOMO.
STOP	[STOP]	Press once to STILL frame VTR. Press again to put VTR into STOP mode.
PLAY TO LOOP	[SHIFT] + [LOOP ENABLE]	Loops From the IN point to the OUT point of a clip continuously.
LOOP ENABLE	[SHIFT] + [PLAY]	Plays clip from beginning to end then repeats.
GOTO end of CLIP	[SHIFT] + [FFWD]	Position to last frame of clip.
GOTO beginning of CLIP	[SHIFT] + [REW]	Position to first frame of clip.
TIME MODE SELECT	[TIME MODE]	Press to toggle between Timecode (TC), VITC (VT) or Tape Timer (TM) display modes.

## 22. VIDEO SERVER SETUP

Configuring the Profile for operation with Grass Valley Group Native Protocol

(1) Configuring the PDR **AND** (2) Opening a Prolink session **MUST** be done **BEFORE** the DNF System can be used.

### a. CONFIGURING THE PROFILE FOR NATIVE MODE

The ST300 Controller with NATIVE protocol communicates with the PROFILE through the PROLINK program, on the PROFILE. Prolink uses Configuration Files found in the PROFILE/CONFIGS Directory. These files are called: VTR1.CFG, VTR2.CFG, VTR3.CFG and VTR4.CFG. These files do not affect the operation of VDR Panel. Prolink and VDR Panel share resources so that the total number of PROLINK channels used and VDR Panels opened cannot exceed the available number of resources (typically 4 channels).

If CFGEDLIN.EXE is in the Profile directory, use CFGEDLIN.EXE to configure the .CFG files.

If you do not have CFG.EXE, install PDRCFG.EXE. Instructions for installing PDRCFG.EXE accompany the disk.

### b. OVERVIEW OF PROFILE CONNECTIONS

Physical access to the Profile is made through its RS-422 breakout box.

A Profile session activated with Prolink establishes which port(s) Profile will use for serial communications.

The communications link is complete when a connection is made from a connector on the ST300 to an open session\port on the Profile.

A correctly configured connection consists of a connector and a channel.

Connections for the ST300 are called CN1, CN2, CN3 and CN4 and refer to the 9-pin ports on the back of the ST300 labeled VTR1, VTR2, VTR3 and VTR4.

Channels for the ST300, CH A, CH B, CH C and CH D refer to the Profile's Channel 1, Channel 2, Channel 3 and Channel 4.

The numeric\alpha translation is made in the ST300 in order to comply with the VDR Panel Software which refers to the numbered channels as Panel A, Panel B, Panel C and Panel D.

**c. CONNECTION AND CHANNEL ASSIGNMENTS**

- 1) Press [MENU] to enter Menu Mode.
- 2) Turn Wheel until “Press VTR key for CH and CN assignments” is displayed.
- 3) Press VTR [1] key.  
**NOTE:** VTR [X] toggles between CH and CN assignments
- 4) “VTR 1 Connection” is displayed on the top line.  
The bottom line of the display shows “CHA CHB CHC >>> OFF”
- 5) Press the keys under these selections to choose a channel. Select “>>>” to view more channels.
- 6) Repeat steps 3-5 for VTRs 2, 3 and 4.
- 7) Press [ESC] at any time to exit menu mode.

**NOTE:** Set all unused VTR Connections and Channels to OFF.

## 23. COMPLETING THE PROFILE CONNECTION

So far in this setup, the session P1 has been opened on the Profile and is ready for communication.

Noting the port/session number just selected (P1), locate the P1 connector on the Profile's breakout box and connect an RS-422 cable from Port 1 to the connection called "VTR1" on the back of the ST300.

The default values for channel connections CHA, CHB, CHC and CHD on the ST300 are for VTR1 (CN1). Upon connection, the ST300 will be communicating with the Profile on all available channels.

This is the connection just built:

From: Profile Session P1 On Port 1		To: ST300 'VTR1' <b>Connection 1</b>
VTR	Connection	Channel
1	CN1	CHA
2	CN1	CHB
3	CN1	CHC
4	CN1	CHD

### a. PROFILE CONNECTION OPTIONS

Open another session and connect an RS-422 cable to another "VTR" label on the back of the ST300.

From the setup menu on the ST300, assign any ST300 VTR to the new connection (CN).

The ST300 VTR just assigned will be communicating on with the Profile via the new connector.

The program displays a screen titled "Channels." Assign a Video, Audio and Timecode CODECs, Video Input and Video Output as required to Channels 1-4. If a resource is in use, it will be highlighted in Red.

Click OK when all assignments have been made.

### b. DRIVE/DIRECTORY SELECTION

To change the PROFILE Drive or Directory where Clips will be saved:

- 1) Press [**MENU**] and scroll to the Drive/Directory selection.
- 2) Select Drive or Directory by pressing the Softkey under the menu item.
- 3) Scroll to the desired Drive/Directory and press [**ENTER**].

The selected drive/directory will be used for locating and loading clips.

**NOTE:** When a Drive/Directory changes, the Clip List created using a different Drive/Directory is no longer valid. Set all unused VTR Connections and Channels to OFF.

**c. NAMING CONVENTIONS**

The ST300 Native Mode Controller can load clips that meet the following requirements:

- 1) Clip names cannot exceed 8 characters.
- 2) A space cannot be embedded within the Clip Name.
- 3) The clip name must be in upper case characters only.
- 4) All special characters can be used.

## 24. SPECIFICATIONS

### a. ST300

Power:	90 VAC to 265 VAC adapter supplied with IEC connector
Size:	(L" x W" x H") 12" x 6" x 1.5" (front) 3.0" (rear)
Weight:	4 lbs.
Rear Panel Connectors:	VTR1, VTR2, VTR3, VTR4 (All DB9F) GPI (DB15F) Power (DB9M) Aux (DB9F)
Display:	Easy to read 2-line, back-lit LCD display (User adjustable contrast)
Jog/Shuttle Wheel:	With mechanical detents.
Optional "T"-bar:	Slo-mo 0-200% of Play Speed

### RS422 Serial Connector 9-Pin D-Type, Female (DB9F)

Pin #	1	Frame Ground	6	Receive Common
	2	Receive A ←	7	Receive B ←
	3	Transmit B →	8	Transmit A →
	4	Transmit Common	9	Frame Ground
	5	Spare		

### Power Connector 9-Pin D-Type, Male (DB9M)

Pin #	1	+5v DC	6	+5 VDC
	2	+5v DC	7	Ground
	3	Ground	8	Ground
	4	+12 VDC	9	Ground
	5	-12 VDC		

## GPI IN/OUT Connector 15-Pin D-Type, Female (DB15F)

Pin #	Function	Pin #	Function
1	GPI OUT 1	9	GPI IN 1 = RECORD
2	GPI OUT 2	10	GPI IN 2 = PLAY
3	GPI OUT 3	11	GPI IN 3 = STOP
4	GPI OUT 4	12	GPI IN 4 = RECUE
5	GPI OUT 5	13	GPI IN 5 = LOAD
6	GPI OUT 6	14	GPI IN 6 = NEXT CUE
7	GPI OUT 7	15	GPI IN 7 = LAST CUE
8	Common: GPI IN and GPI OUT		

## AUX PORT RS422 SERIAL CONNECTOR 9-Pin D-Type, Female

Pin #	1	Frame Ground	6	Transmit Common
	2	Receive A ←	7	Receive B ←
	3	Transmit B →	8	Transmit A →
	4	Receive Common	9	Frame Ground
	5	Spare		

### b. ST420 (SHOTBOX)

Power: 90 VAC to 265 VAC adapter supplied with IEC connector

Size: [L" x W" x H"] 11.5" x 6 .5" x 1.75" (front) 3.5" rear)

Weight: 4 lbs.

Rear Panel Connectors:	Out	(DB9F)
	GPI	(DBF15F)
	Power	(DB9M)
	Aux	(DB9F)

## RS422 SERIAL CONNECTOR 9-Pin D-Type, Female

Pin #	1	Frame Ground	6	Transmit Common
	2	Transmit A →	7	Transmit B →
	3	Receive B ←	8	Receive A ←
	4	Receive Common	9	Frame Ground
	5	Spare		

## POWER CONNECTOR

### 9-Pin D-Type, Male

Pin #	1	+5v DC	6	No Connection
	2	+5v DC	7	Ground
	3	Ground	8	Ground
	4	No Connection	9	Ground
	5	No Connection		

## 25. TROUBLESHOOTING

### ST420 TROUBLESHOOTING

- a. All keys are RED - no communication with ST300.
- b. All keys are dark - No communication between the ST300 and the Video Server.
- c. The version of the ST420 must comply in the software version with the ST300 it is connected to.

To determine the software version of the ST420 do the following:

- 1) Press **[SHIFT]** + **[STOP]** + **[PLAY]**.  
The key that displays the current version is RED.
- 2) The ST420 displays:  
“SELECT ST300 V2.1 or V2.0 or V 3.0.”

Press the key for the software version of ST300 you are using. Please refer to the ST300 to determine the version if needed

# 26. KEY LAYOUT

## ST300 KEY LAYOUT 4000CL-N & 2034CL-N (& -T)

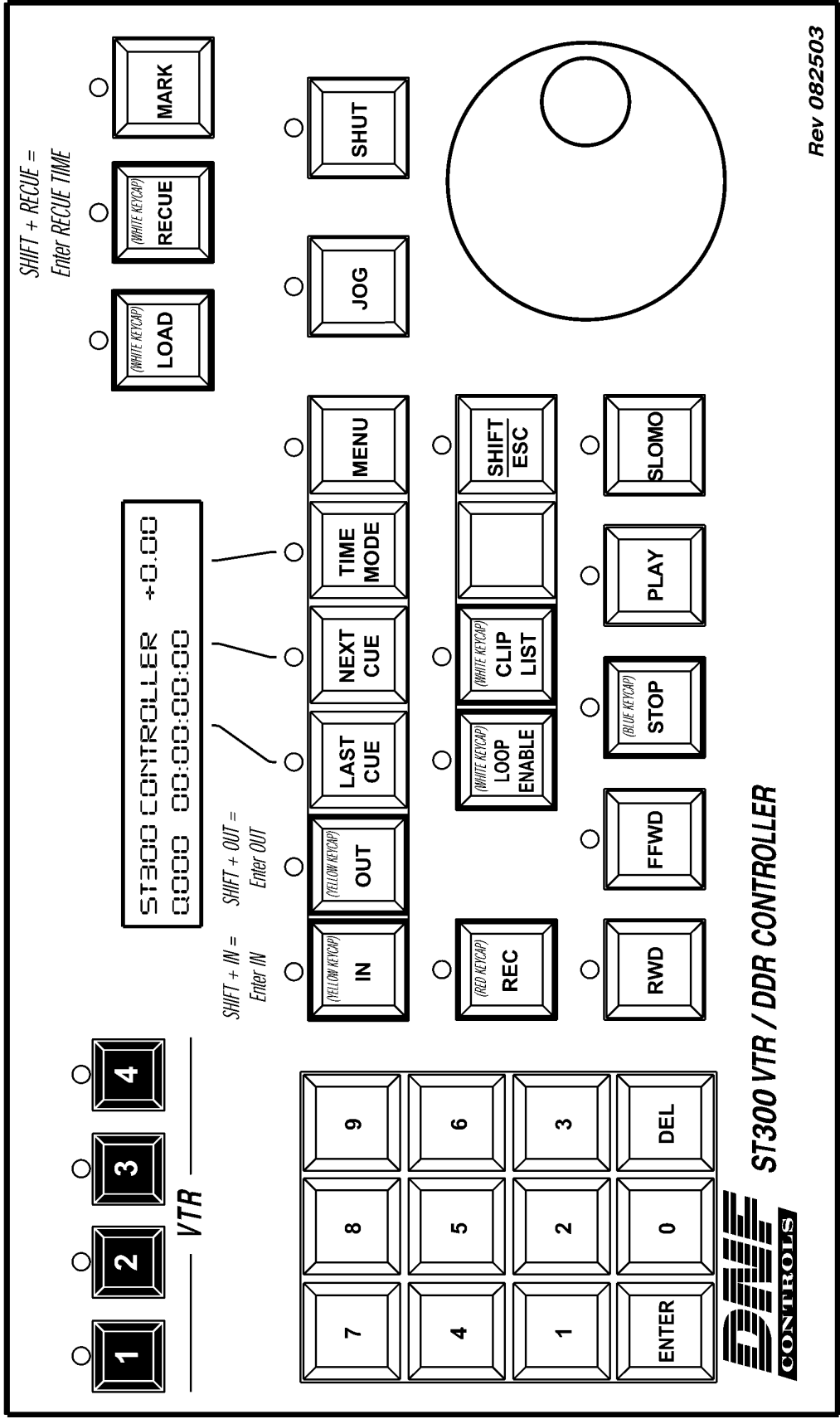

Rev 082503

## 27. DNF CONTROLS LIMITED WARRANTY

DNF Controls warrants its product to be free from defects in material and workmanship for a period of one (1) year from the date of sale to the original purchaser from DNF Controls.

In order to enforce the rights under this warranty, the customer must first contact DNF's Customer Support Department to afford the opportunity of identifying and fixing the problem without sending the unit in for repair. If DNF's Customer Support Department cannot fix the problem, the customer will be issued a Returned Merchandise Authorization number (RMA). The customer will then ship the defective product prepaid to DNF Controls with the RMA number clearly indicated on the customer's shipping document. The merchandise is to be shipped to:

DNF Controls  
12843 Foothill Blvd., Suite D  
Sylmar, CA 91342  
USA

Failure to obtain a proper RMA number prior to returning the product may result in the return not being accepted, or in a charge for the required repair.

DNF Controls, at its option, will repair or replace the defective unit. DNF Controls will return the unit prepaid to the customer. The method of shipment is at the discretion of DNF Controls, principally UPS Ground for shipments within the United States of America. Shipments to international customers will be sent via air. Should a customer require the product to be returned in a more expeditious manner, the return shipment will be billed to their freight account.

This warranty will be considered null and void if accident, misuse, abuse, improper line voltage, fire, water, lightning or other acts of God damaged the product. All repair parts are to be supplied by DNF Controls, either directly or through its authorized dealer network. Similarly, any repair work not performed by either DNF Controls or its authorized dealer may void the warranty.

After the warranty period has expired, DNF Controls offers repair services at prices listed in the DNF Controls Price List. DNF Controls reserves the right to refuse repair of any unit outside the warranty period that is deemed non-repairable.

DNF Controls shall not be liable for direct, indirect, incidental, consequential or other types of damage resulting from the use of the product.

###