



12843 Foothill Blvd.,
Suite D
Sylmar, CA 91342
818 898 3380 voice
818 898 3360 fax
www.dnfcontrols.com

Model 4000CL-AX

400 Clip Fast Access System

FOR *ACCOM AXESS* PROTOCOL

USER MANUAL

Table of Contents

Section	Contents	Page
1.	REVISION HISTORY	3
2.	SYSTEM DESCRIPTION	3
3	SYSTEM INSTALLATION.....	3
4.	VIDEO SERVER SETUP.....	4
5.	LEARN.....	5
6.	RECALL.....	6
7.	RECORDING ON THE AXESS.....	6
8.	TRANSFERRING CUE LISTS.....	6
9.	SETUP MENU.....	8
10.	FUNCTION TABLE.....	10
11.	SPECIFICATIONS.....	11
12.	DNF CONTROLS LIMITED WARRANTY	13

Manual Version..... 2.5 112103
Document No..... 4000CL-AX User Manual

1. REVISION HISTORY

100803	Rev. 2.4	Company header information revised.
112103	Rev. 2.5	Updated Receive Cue List & Transmit Cue List Function description. Added DNF Controls Limited Warranty.

2. SYSTEM DESCRIPTION

The 400 Clip Fast Access System consists of the ST300-SSM VTR Controller and Shotlist Software.

SHOTLIST provides fast access to existing video clips stored on *Axess*.

The SHOTLIST contains up to 400 CLIP IDs, stored in non-volatile memory in the ST300.

Remotely view the CLIP IDs that exist in the *Axess* under control.

Any clip in the SHOTLIST can be quickly loaded by simply entering the 3 digit number associated with its location, then pressing [**LOAD**]. Press [**PLAY**] to play the clip. Press [**RECUE**] to recue to the beginning of the clip.

DEFINITIONS:

- Throughout this document, the Accom *Axess* will be referred to as the “Video Server”.
- The ST300-S/SM is referred to as “ST300”.
- Words surrounded by brackets, for example, [**ENTER**], are keys on the ST300. [**XXX**] + [**XXX**] means hold the two keys down simultaneously.

3. SYSTEM INSTALLATION

1. Plug one end of a 9 conductor, RS422 serial cable into the 9 pin connector (VTR 1, VTR 2, VTR 3 or VTR 4) on the rear of the ST300. Plug the other end of the cable into the 9 pin remote connector on the Video Server.
2. Connect the +5, +12, -12 VDC POWER SUPPLY into the POWER connector on the rear of the ST300. Plug the Power Supply into an outlet, 90 VAC to 240 VAC.
3. Check SETUP MENU prior to using the ST300 to confirm proper Record mode and other User settable modes.
4. Connect the Black Burst Generator through the supplied Sync adapter to the AUX port on the rear of the ST300.

Installation is complete.

CONNECTION DIAGRAM

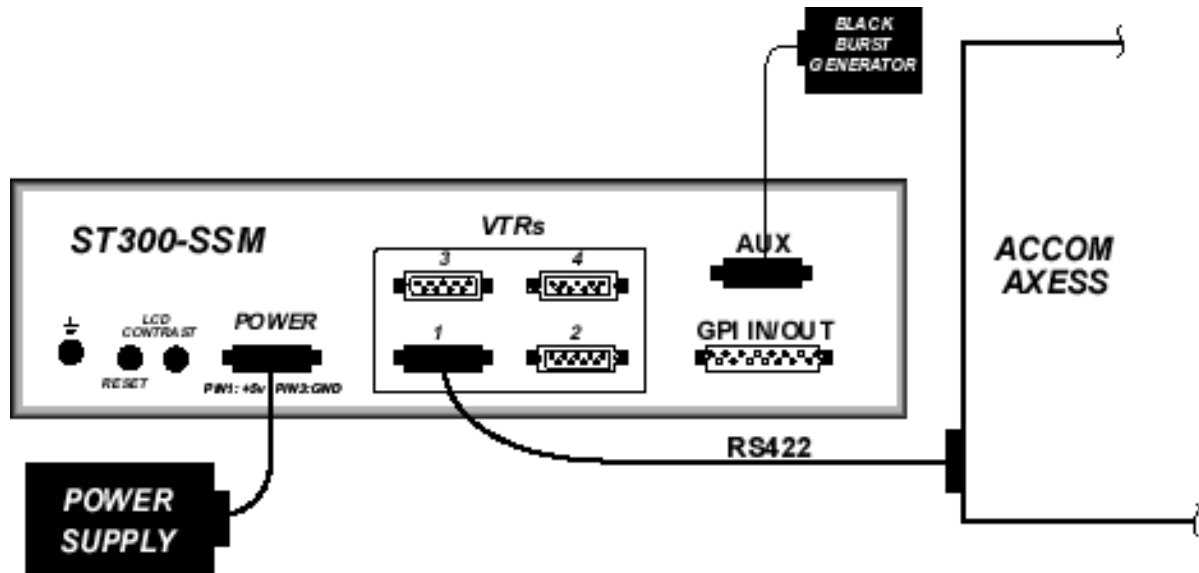

4. VIDEO SERVER SETUP

1. Assign a serial port on the VIDEO SERVER:
 - a. Select 1001 > Setup > Remote Setup > VTR Setup
 - b. Select the channel.
 - c. Enable the RS422 port with the Softkey (example: CH.A – RS422-1)
 - d. Change the protocol to “Sony-2” with the Softkey
 - e. Press Exit > Exit > System Memory > Save
2. Connect the same sync signal that goes into the ST300 AUX port to the Sync connector on the back of the *Axess*. Setup the *Axess* to use External Sync using the *Axess* OnAir panel.

NOTES: The ST300 will default to Tape Time if a non-supported time mode is selected on the ST300.

The ST300 in Clip List mode will display ‘Waiting for *Axess*’ message on the first line of the display due to the delays in the *Axess* Protocol.

Setup is complete.

5. LEARN

1. Select a VTR by pressing VTR [1], VTR [2], VTR [3] or VTR [4]
2. Load the desired Clip using the Clip List function.
 - a. Press [CLIP LIST] to view the list of Clips that exist in the VIDEO SERVER.
 - b. The first line will show: “Enter starting point”
The second line will show the numeric ID of the currently loaded clip.
 - c. Turn the wheel to scroll through the *Axess* clips starting from the currently displayed clip
OR
 - d. Enter the numeric ID (1-9,999,999) using the numeric keypad. The *Axess* will load the entered CLIP ID or go to the next available ID if the entered ID does not exist. You will see the CLIP ID changing as the *Axess* tries to find the next available ID. You can terminate the search by hitting any key and entering a new starting point.
3. Turn the wheel. The top line of the display will show “xxxxxxx y”
Where “xxxxxxx” is the numeric CLIP ID, y= ‘S’ if it is a Still, or ‘C’ if it is a clip. Turn the wheel to scroll forward through the list of available clips.
4. Press [LOAD] to load the current CLIP ID shown on the top line of the display.
5. Locate the clip to the desired IN time.
6. Repeat steps 1 – 5 until clips are loaded into the desired VTRs
7. Set the GANG mode, if required.
8. Select the desired Cue Point by pressing [NEXT CUE], [LAST CUE] or by manually entering the Cue Point using the numeric keypad.

The selected Cue Point number is shown on the bottom line of the display.
9. Press [SHIFT] + [MARK] to start the LEARN.
10. The first line of the display will show “Select VTRs:”
the second line of the display will show “Mark-Lrn, ESC-cancel”.
11. Press VTR [1], [2], [3] or [4] to select the VTR you want to learn into the current Cue Point. If the VTRs are GANGED, select one VTR that is part of the Gang. The rest of the Gang will learn automatically.

The first line of the display will show you the VTR number you have chosen.
12. Press [MARK] to complete the LEARN
OR
Press [ESC] to exit without LEARNING.

The ST300 will: LEARN (save) the VTR Number (1,2,3,4), loaded CLIP ID and current IN time to the selected Cue Point.

6. RECALL

1. Select the desired Cue Point by pressing [NEXT CUE], [LAST CUE] or by manually entering the Cue Point using the numeric keypad.
The selected Cue Point number is shown on the bottom line of the display.
2. Press [LOAD] on the ST300.
The ST300 will automatically load the Learned clips on the Learned VTRs, cue the clips to the Learned time, then set the Learned GANG mode.

7. RECORDING ON THE AXESS FROM THE ST300

1. Remote protocol needs to be set for SONY 2.
2. Sync needs to be set for INPUT. The ST300, *Axess* and source need to have the same sync.
3. Preroll on the ST300 needs to be set.
4. RECORD DELAY in the ST300 needs to be set to 4 frames. (Some experimentation might be needed to find the correct number to re-record over the first frame of a clip)
5. On the *Axess*: SETUP > UTILS SETUP > TIME CODE
Pre- & Post-Roll need to be set to ON and duration needs to match duration on the ST300.
6. Press [SHIFT] + [REC] to set record duration.
7. Press [REC] to start recording. Press [STOP] to stop recording.

8. TRANSFERRING CUELIST

The TRANSMIT CUELIST function allows you to transmit your list of Cue Points to a PC, using the provided utility software on the PC, or to another ST300. Transfer to a PC requires OpSuite 3.0 software, which runs on a Windows-based computer. Contact DNF Controls for more information.

To Transmit Cue Points to the ST300:

1. Connect the VTR4 connector on the back of the ST300 to the VTR4 connector of the receiving ST300 using RS422 9-pin cable with TX and RX lines crossed. (A “Turnaround” cable)
2. Press [MENU].
3. Scroll the wheel until “Transmit CUE List? YES=Enter, Exit=ESC” is displayed.
4. Press [ENTER] to start transmitting. The Display shows “Waiting to transmit” on the first line.
5. When the Receiver is ready, transfer starts automatically. The Display now shows ”Transmitting cuelist”.

6. After the transfer is over, the display shows “Transfer is over” for one second and then shows “Waiting to transmit” again.
7. Connect another ST300 to transmit the list again **OR** press [ESC] twice to exit the MENU mode.

To Transmit Cue Points to the PC:

1. Connect the VTR4 connector on the back of the ST300 to one of the COM ports on the PC using a RS422 to RS232 adapter.
2. Repeat steps 2-8 of the TRANSMIT CUE POINTS to the ST300 section.

RECEIVE CUELIST FUNCTION.

The RECEIVE CUELIST function allows you to receive your list of Cue Points from a PC or from another ST300. Transfer to a PC requires OpSuite 3.0 software, which runs on a Windows-based computer. Contact DNF Controls for more information.

To Receive Cue Points from the ST300:

1. Connect the VTR4 connector on the back of the ST300 from the VTR4 connector of the transmitting ST300 using RS422 9-pin cable with TX and RX lines crossed. (A “Turnaround” Cable)
2. Press [MENU].
3. Scroll the wheel until “Receive CUE List? YES=Enter, Exit=ESC” is displayed.
4. Press [ENTER] from start receiving. The Display shows “Waiting to receive” on the first line.
5. When the Transmitter is ready, transfer starts automatically. The Display now shows “Receiving cuelist”.
6. After the transfer is over the display shows “Done-Success! Press any key...”
7. Press any key. The display shows “Receive cuelist?” message.
8. Press [ESC] twice to exit the MENU mode.

To Receive Cue Points from the PC:

1. Connect the VTR4 connector on the back of the ST300 to one of the COM ports on the PC using RS422 to RS232 adapter
2. Repeat steps 2-8 of the RECEIVE CUE POINTS from the ST300 section.

9. SETUP MENU

Press [MENU]. The MENU indicator will turn on.

Turn the Wheel to select item to change.

Press [MENU] **OR** use the Softkeys to change the desired mode for that option.

Turn the Wheel at anytime to select another item.

Press [ESC] at anytime to exit SETUP MENU. The MENU indicator will turn off.

MENU MODES: (Turning Wheel clockwise)

WIND MODE Press Softkey to select:
HOLD (fast wind is maintained only while key is pressed)
OR
LATCH (fast wind is initiated and maintained with momentary key press)
Select fast wind speed (3.9 to 23.7) by pressing Softkey below SPD.

SLOMO ST300 display shows:

SLOMO with:	WHEEL
TBAR	Speed Prset

Press Softkey [**TBAR**] (or [**WHEEL**]) to toggle between them.

NOTE- The T-BAR has a speed range of 0 → +200 with a detent at +100% play speed **OR** 0 → 100%, with a detent at +100.

For Wheel only:

Press Softkey [**SPEED**] to select SLOMO speed ranges:

Press Softkey to select: 0 → +200 **OR** -100 → +200.

Press Softkey [**BACK**] to return to SLOMO MENU.

Press [ESC] to exit SETUP MENU.

OR turn the wheel to select another item.

For Wheel only:

Press Softkey [**PRSET**] to select the SLOMO Preset Speed Mode

Press Softkey [**UPDATE**]. When exiting SLOMO mode, the last used speed is saved in the Preset Speed register.

Press Softkey [**STATIC**]. The Preset Speed register is NOT updated when exiting SLOMO mode. It is only changed by [SHIFT] + [SLOMO] (PRESET SLOMO).

**ST300
SETUP**

ST300 SETUP	
Clear Cues	SetDefault

Press Softkey beneath ClearCues to clear all Cue Points to 00:00:00:00.

Press Softkey [**YES**] when asked “Are You Sure?”

Press Softkey beneath SetDefault to set ST300 to default settings.

Press Softkey [**YES**] when asked “Are You Sure?”

DISPLAY SOFTWARE VERSION The version number for the currently installed software is displayed.

TRANSMIT CUE LIST Transfer Cuelist to another ST300 or a PC.

RECEIVE CUE LIST Receive Cuelist from another ST300 or a PC.

10. FUNCTION TABLE

Function	Key Press	Description
GOTO ENTERED TIME	[SHIFT] + [RECUE]	Search the VTR to the manually entered time Use the ST300 numeric keypad. Press [ENTER] or [RECUE].
GANG	[SHIFT] + [VTR #1] OR [SHIFT] + [VTR #2] OR [SHIFT] + [VTR #3] OR [SHIFT] + [VTR #4]	Individually press the VTR keys to be included in the gang. The LED above the key will turn on. Press the VTR key again to remove from gang, the LED above the key will turn off. Press [ESC] to exit. The VTR LEDs that are on show the gang. The flashing LED shows which VTR is currently selected.
FFWD	[FFWD]	Press and HOLD to shuttle. Release key to stop. Set WIND Speed in MENU.
JOG	[JOG]	Select JOG mode and enable Wheel.
LAST CUE	[LAST CUE]	Step to the previous Cue Point Location.
NEXT CUE	[NEXT CUE]	Step to the next Cue Point Location.
REWIND	[RWD]	Press and HOLD to shuttle. Release key to stop. Set WIND Speed in MENU.
SHUTTLE	[SHUTTLE]	Select SHUTTLE mode and enable Wheel.
SLOMO	[SLOMO]	Press [SLOMO] to slo-mo the VTR. Turn the wheel (or move the T-Bar if available) to change the play speed. Press [SLOMO] to STILL frame OR press any transport key to exit SLOMO.
SLO-MO SPEED PRESET	[SHIFT] + [SLOMO]	For WHEEL ONLY : Press [SHIFT] + [SLOMO] to preset the slo-mo speed. Turn wheel to select desired speed. Press [ESC] or any transport key to exit.
STOP	[STOP]	Press once to STILL frame VTR. Press again to put VTR into STOP mode.
TIME MODE SELECT	[TIME MODE]	Press to toggle between Timecode (TC), VITC (VT) or Tape Timer (TM) display modes
LOOP PLAY	[SHIFT] + [PLAY]	Press to Loop Play the VTR

11. SPECIFICATIONS

ST300

Power:	90 VAC to 265 VAC adapter supplied with IEC connector
Size:	(L" x W" x H") 12" x 6" x 1.5" (front) 3.0" (rear)
Weight:	4 lbs.
Rear Panel Connectors:	VTR1, VTR2, VTR3, VTR4 (All DB9F) GPI (DBF15F) Power (DB9M) Aux (DB9F)
Display:	Easy to read 2 line, back-lit LCD display (User adjustable contrast)
Jog/Shuttle Wheel:	With mechanical detents.
Optional "T"-bar:	Slo-mo 0-200% of Play Speed

RS422 SERIAL CONNECTOR 9 Pin D type, female (DB9-F)

Pin #	1	Frame Ground	6	Receive Common
	2	Receive A ←	7	Receive B ←
	3	Transmit B →	8	Transmit A →
	4	Transmit Common	9	Frame Ground
	5	Spare		

POWER CONNECTOR 9 Pin D type, male (DB9-M)

Pin #	1	+5v DC	6	+5 VDC
	2	+5v DC	7	Ground
	3	Ground	8	Ground
	4	+12 VDC	9	Ground
	5	-12 VDC		

GPI IN/OUT Connector: 15 Pin D type, female (DB15F)

Pin #	Description	Function
1	GPI 1 Out	
2	GPI 2 Out	
3	GPI 3 Out	
4	GPI 4 Out	
5	GPI 5 Out	
6	GPI 6 Out	
7	GPI 7 Out	
8	Ground	
9	GPI 1 In	Play
10	GPI 2 In	Stop
11	GPI 3 In	Recue
12	GPI 4 In	Next Cue
13	GPI 5 In	Last Cue
14	GPI 6 In	Recall
15	GPI 7 In	

12. DNF CONTROLS LIMITED WARRANTY

DNF Controls warrants its product to be free from defects in material and workmanship for a period of one (1) year from the date of sale to the original purchaser from DNF Controls.

In order to enforce the rights under this warranty, the customer must first contact DNF's Customer Support Department to afford the opportunity of identifying and fixing the problem without sending the unit in for repair. If DNF's Customer Support Department cannot fix the problem, the customer will be issued a Returned Merchandise Authorization number (RMA). The customer will then ship the defective product prepaid to DNF Controls with the RMA number clearly indicated on the customer's shipping document. The merchandise is to be shipped to:

DNF Controls
12843 Foothill Blvd., Suite D
Sylmar, CA 91342
USA

Failure to obtain a proper RMA number prior to returning the product may result in the return not being accepted, or in a charge for the required repair.

DNF Controls, at its option, will repair or replace the defective unit. DNF Controls will return the unit prepaid to the customer. The method of shipment is at the discretion of DNF Controls, principally UPS Ground for shipments within the United States of America. Shipments to international customers will be sent via air. Should a customer require the product to be returned in a more expeditious manner, the return shipment will be billed to their freight account.

This warranty will be considered null and void if accident, misuse, abuse, improper line voltage, fire, water, lightning or other acts of God damaged the product. All repair parts are to be supplied by DNF Controls, either directly or through its authorized dealer network. Similarly, any repair work not performed by either DNF Controls or its authorized dealer may void the warranty.

After the warranty period has expired, DNF Controls offers repair services at prices listed in the DNF Controls Price List. DNF Controls reserves the right to refuse repair of any unit outside the warranty period that is deemed non-repairable.

DNF Controls shall not be liable for direct, indirect, incidental, consequential or other types of damage resulting from the use of the product.

###