



12843 Foothill Blvd.,  
Suite D  
Sylmar, CA 91342  
818 898 3380 voice  
818 898 3360 fax  
[www.dnfcontrols.com](http://www.dnfcontrols.com)

# **Model 4000CL-L (and 4000CL-L-T)**

## **400 CLIP FAST ACCESS SYSTEM**

**Louth Protocol**

**VERSION 3.0 SOFTWARE**

**NOTE: Supports up to 4 Video Server Channels**

## **USER MANUAL**

# Table of Contents

<b>1.</b>	<b>REVISION HISTORY</b>	<b>3</b>
<b><i>GETTING STARTED...</i></b>		<b>4</b>
<b>2.</b>	<b>SYSTEM DESCRIPTION</b>	<b>4</b>
	DEFINITIONS	4
<b>3.</b>	<b>SYSTEM INSTALLATION</b>	<b>5</b>
<b>4.</b>	<b>VIDEO SERVER SETUP</b>	<b>7</b>
<b>5.</b>	<b>LOAD A CLIP</b>	<b>7</b>
<b>6.</b>	<b>VIEW THE CLIP ID OF THE CURRENTLY LOADED CLIP</b>	<b>7</b>
<b>7.</b>	<b>LEARN A CLIP OR CLIP COMBINATION</b>	<b>8</b>
<b>8.</b>	<b>RECALL A CLIP OR CLIP COMBINATION</b>	<b>8</b>
<b>9.</b>	<b>RECUE THE CURRENTLY LOADED CLIP</b>	<b>8</b>
<b><i>ADVANCED FEATURES...</i></b>		<b>9</b>
<b>10.</b>	<b>CREATE A CLIP</b>	<b>9</b>
	a. SET THE RECORD DURATION	9
	b. CREATE A NEW NAME	9
	c. RECORD A CLIP	10
<b>11.</b>	<b>CREATING SUBCLIPS</b>	<b>11</b>
	a. MARK IN (OUT) POINT	11
	b. DELETE IN (OUT) POINT	11
	c. MANUALLY ENTER IN (OUT) POINT	11
	d. CREATE SUBCLIP	11
<b>12.</b>	<b>TRANSFER CUE LIST</b>	<b>12</b>
	a. TRANSMIT CUE LIST FUNCTION	12
	b. RECEIVE CUE LIST FUNCTION	13
<b><i>REFERENCE...</i></b>		<b>14</b>
<b>13.</b>	<b>SETUP MENU</b>	<b>14</b>
<b>14.</b>	<b>FUNCTION TABLE</b>	<b>17</b>
<b>15.</b>	<b>SPECIFICATIONS</b>	<b>18</b>
<b>16.</b>	<b>KEY LAYOUT</b>	<b>20</b>
<b>17.</b>	<b>DNF CONTROLS LIMITED WARRANTY</b>	<b>21</b>

Manual Version..... 3.9 080604  
Document No.....4000CL-L User Manual

# 1. REVISION HISTORY

052803	Rev. 3.1	Updated Section 11, SETUP MENU, changed Key Layout.
062703	Rev. 3.2	Changed Key Layout.
070103	Rev. 3.3	Added Recall Mode setup.
112103	Rev. 3.4	Updated Transmit Cue List and Receive Cue List Function description. Added DNF Controls Limited Warranty.
120903	Rev. 3.5	Added CREATING SUBCLIPS section.
012204	Rev. 3.6	Changed Key Layout.
020504	Rev. 3.7	Added note to cover and System Description: Supports up to 4 Video Server Channels.
080604	Rev. 3.8	Changed T-bar dimension.

## *Getting Started . . .*

### **2. SYSTEM DESCRIPTION**

The 400 Clip Fast Access System consists of:

#### **ST300-SSM VTR/DDR CONTROLLER AND SHOTLIST SOFTWARE**

The ST300 controls up to 4 video channels individually or ganged.

**Shotlist** Software. Clip Based, Efficient, Reliable, Customizable.

**FAST** access to 400 video clips in any Digital Disc Recorder or Video Server using Louth VDCP Protocol.

Quickly & Easily assign video clips to 400 locations in the SHOTLIST.

Enter a 1-, 2- or 3-digit number to access any location in the SHOTLIST. Then LOAD and PLAY. It's that easy.

Ideal for:

- ✓ Backup in case of On-Air Automation failure
- ✓ News Shows
- ✓ Game Shows
- ✓ Sports Shows
- ✓ Anywhere that requires fast access to pre recorded video clips

Ideal as Betacart/Flexcart replacement.

### **DEFINITIONS**

- Throughout this document VTR, DDR, VDR & Video Server will be referred to collectively as "Video Server."
- The ST300-S/SM is referred to as "ST300."
- Words surrounded by brackets, for example, [ENTER], are keys on the ST300. [XXX + [XXX]] means hold the two keys down simultaneously. XXX = Key name.

### 3. SYSTEM INSTALLATION

- a. Plug one end of a 9-conductor, RS422 serial cable into the VTR 1 (2, 3 or 4) connector on the rear of the ST300. Plug the other end of the cable into the REMOTE connector on the Video Server.
- b. Connect the supplied POWER SUPPLY, APX#4108, into the POWER connector on the rear of the ST300. Plug the Power Supply into an outlet, 90 VAC – 240 VAC.
- c. Assign logical Louth ports to ST300's VTR's connectors.
  - 1) Press **[MENU]**.
  - 2) Turn the wheel until VTR Louth Address is displayed.
  - 3) Press VTR[1], VTR[2], VTR[3] or VTR[4] to select VTR.
  - 4) Assign a Louth Port address by entering a style number 0-9 using the numeric keypad. (0 turns that channel **OFF**.)
  - 5) The second line of the display will show "Input=Enter, Out=ESC."
  - 6) Press **[ENTER]** to select an Input Port.  
(A "-" will appear in front of the selected number.)  
**OR**  
**[ESC]** to select an Out Port.
  - 7) Repeat steps 3 - 6 above to assign Louth Address to ALL ST300 VTRs you want to use.
  - 8) Press **[ESC]** to exit the MENU mode.
- d. Check **SETUP MENU** prior to using the ST300 to confirm proper Record mode and other User settable modes.

Installation is complete.

# SYSTEM CONNECTION DIAGRAM

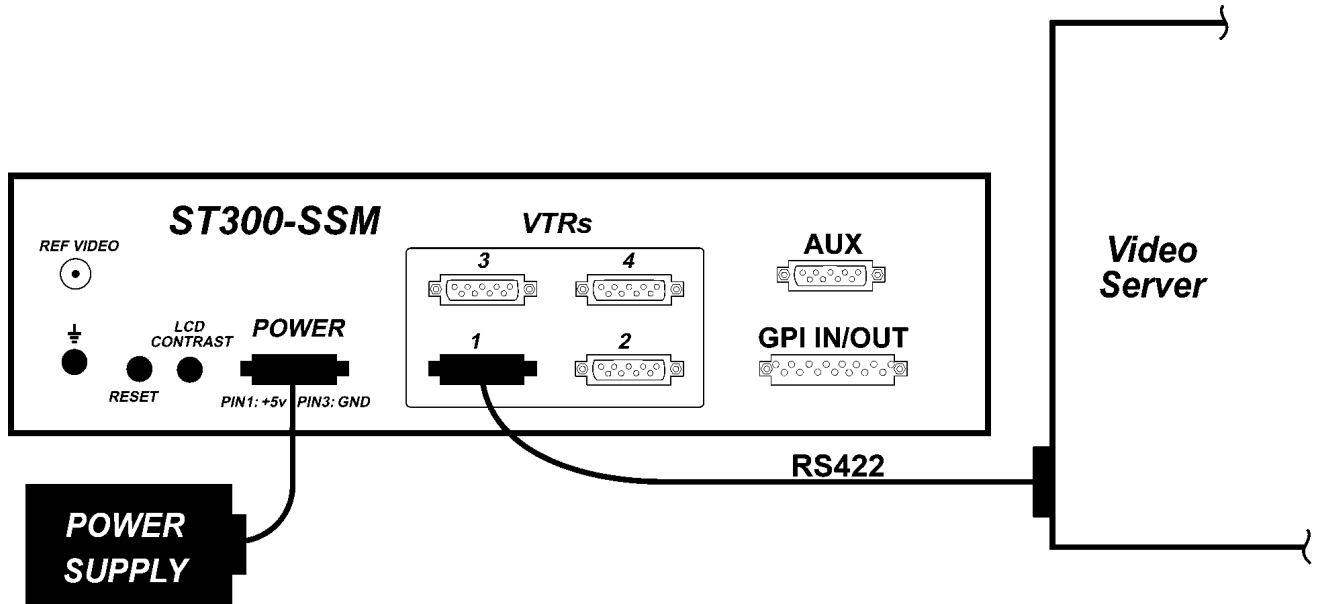

## 4. VIDEO SERVER SETUP

- a. Select LOUTH VDCP communications protocol on the VIDEO SERVER to be controlled.
- b. If required, assign a serial port on the VIDEO SERVER through which the ST300 will control it.

**NOTE:** In LOUTH mode, the VIDEO SERVER may only allow Full Record. INSERT and ASSEMBLE record modes may be disabled.

Setup is complete.

## 5. LOAD A CLIP

- a. Select a VTR by pressing VTR[1], VTR[2], VTR[3], or VTR[4].
- b. Press [CLIP LIST] to view the list of CLIP IDs that are resident on the Video Server. The CLIP LIST indicator will turn on.
- c. Turn the Wheel to view the existing CLIP IDs on the video server.

Turn the Wheel clockwise to scroll forward, or counter-clockwise to scroll backward, through the list of available CLIPs. Backward scrolling is limited to the last 10 CLIP IDs viewed.

**OR**

Manually enter a CLIP ID using the ST300 numeric keypad, or PC keyboard (if KBIO option).

- d. Press [LOAD] to load the selected CLIP ID for playback.
- e. Repeat steps a - d to load clips on desired VTRs.
- f. Set the GANG mode, if required.

## 6. VIEW THE CLIP ID OF THE CURRENTLY LOADED CLIP

Press [SHIFT] + [LOAD]. The bottom line will show the name of the loaded clip.

## 7. LEARN A CLIP OR CLIP COMBINATION

- a. Load a clip on the desired VTRs. (See Section 5, “LOAD A CLIP.”)
- b. Select the desired Cue Point by pressing [NEXT CUE], [LAST CUE] or by manually entering the Cue Point using the numeric keypad. The selected Cue Point number is shown on the bottom line of the display.
- c. Press [SHIFT] + [MARK] to start the LEARN. The first line of the display will show “Select VTRs:” The second line of the display will show “Mark-Lrn, ESC-cancel.”
- d. Press VTR [1], [2], [3] or [4] to select the VTR to be learned into the current Cue Point. If the VTRs are ganged, select one VTR that is part of the Gang. The rest of the Gang will be learned automatically.
- e. Press [MARK] to complete the LEARN.

**OR**

Press [ESC] to exit without LEARNING.

The ST300 will: LEARN (save) the VTR Number (1,2,3,4), loaded CLIP ID and current IN time to the selected Cue Point.

## 8. RECALL A CLIP OR CLIP COMBINATION

- a. Select the desired Cue Point by pressing [NEXT CUE], [LAST CUE] or by manually entering the Cue Point using the numeric keypad.

The selected Cue Point number is shown on the bottom line of the display.

- b. Press [LOAD] on the ST300.

The ST300 will automatically load the Learned clips on the Learned VTRs, cue the clips to the Learned time, then set the Learned GANG mode.

## 9. RECUE THE CURRENTLY LOADED CLIP

- a. Press [SHIFT] + [RECUE].
- b. Enter the desired time to search to using the ST300’s numeric keypad.
- c. Press [ENTER] to search to the entered time.

**OR**

Press [ESC] to exit without searching.

## *Advanced Features . . .*

### **10. CREATE A CLIP**

**NOTE:** New clips can be created ONLY if the INPUT Port is selected.

#### **a. SET THE RECORD DURATION**

- 1) Press **[SHIFT] + [RECORD]**.
- 2) The display shows current record duration. The second line of the display shows “Enter Record Length” prompt.
- 3) Enter the desired record length using the numeric keypad.
- 4) Press **[ENTER]** to save the new record length and exit  
**OR**  
Press **[ESC]** to exit without saving.

**NOTE:** Set Factory Defaults (in the SETUP MENU) to set the record duration to 1 hour.

#### **b. CREATE A NEW NAME**

- 1) Press **[CLIP LIST]**. The CLIP LIST indicator turns on. The display will show “CREATE NEW CLIP.”
- 2) Press **[LOAD]**. The display will show the default CLIP ID.
- 3) Press **[LOAD]** to accept the default CLIP ID.  
**OR**  
Use **[NEXT CUE]**, **[LAST CUE]** and Wheel to create a CLIP ID. Use the **[NEXT CUE]** and **[LAST CUE]** keys to position the cursor. Turn the Wheel to select the desired letter.  
**OR**  
Create an ID using the numeric keypad, with a maximum of eight characters. Press **[ENTER]**.
- 4) Press **[LOAD]** to create the selected CLIP ID. If the selected CLIP ID already exists, a warning message will be displayed. To load the existing clip, press **[ENTER]**. Press **[ESC]** to exit without loading the existing clip.

### c. **RECORD A CLIP**

**NOTE:** To record a clip, the video server must have enough memory to record the entire clip. Video input must be connected to the Record Channel.  
The ST300 Port selected for recording must be an Input Port [a “-“ (minus) number].

- 1) Set the desired record duration as described in Section 10.a., “**SET THE RECORD DURATION.**”
- 2) Create a new name as described above in Section 10.b., “**CREATE A NEW NAME.**”
- 3) Press [**RECORD**] to start recording.
- 4) Press [**STOP**] to stop recording.

## 11. CREATING SUBCLIPS

### a. MARK IN (OUT) POINT

- 1) Press **[IN]** (**[OUT]**).
- 2) The current Timecode is saved as **[IN]** (**[OUT]**) point. **IN** (**[OUT]**) indicator turns on.

### b. DELETE IN (OUT) POINT

- 1) Press **[DEL]** and **[IN]** (**[OUT]**).
- 2) The **[IN]** (**[OUT]**) point is cleared. The **[IN]** (**[OUT]**) indicator is turned off.

### c. MANUALLY ENTER IN (OUT) POINT

- 1) Press **[SHIFT]** and **[IN]** (**[OUT]**).
- 2) The display prompts to enter new **[IN]** (**[OUT]**) point
- 3) Type in the new timecode using numeric keypad.
- 4) Press **[ENTER]** to save the new **[IN]** (**[OUT]**) point.  
**OR**

Press **[ESC]** to leave without saving  
**OR**

Press **[RECUE]** to save the new **[IN]** (**[OUT]**) point and recue to it.

### d. CREATE SUBCLIP

- 1) Mark or Enter **IN** and **OUT** points as described above
- 2) Press **[SHIFT]** + **[CLIP LIST]** keys.
- 3) The display prompts to enter a subclip name.
- 4) Enter the name using the Shotbox keyboard or the numeric keypad
- 5) Press **[ENTER]**.
- 6) The subclip with the specified name and the **IN** and **OUT** points is created.

## 12. TRANSFER CUE LIST

### a. TRANSMIT CUE LIST FUNCTION

The TRANSMIT CUE LIST function allows you to transmit your list of Cue Points to a PC, using the provided utility software on the PC, or to another ST300. Transfer to a PC requires OpSuite 3.0 software, which runs on a Windows-based computer. Contact DNF Controls for more information.

#### 1) TO TRANSMIT CUE POINTS TO THE ST300

- a) Connect the VTR4 connector on the rear of the ST300 to the VTR4 connector of the receiving ST300 using an RS422 9-pin cable with TX and RX lines crossed.  
(A “turnaround” cable)
- b) Press **[MENU]**.
- c) Scroll the wheel until “Transmit CUE List? YES=Enter, Exit=ESC” is displayed.
- d) Press **[ENTER]** to start transmitting.  
The Display shows “Waiting to transmit” on the first line.
- e) When the Receiver is ready, transfer starts automatically.  
The Display now shows “Transmitting cuelist.”
- f) After the transfer is over, the display shows “Transfer is over” for one second and then shows “Waiting to transmit” again.
- g) Connect another ST300 to transmit the list again.  
**OR**

Press **[ESC]** twice to exit the MENU mode.

#### 2) TO TRANSMIT CUE POINTS TO THE PC

- a) Connect the VTR4 connector on the back of the ST300 to one of the COM ports on the PC using a RS422 to RS232 adapter.
- b) Repeat steps b – g of “**TO TRANSMIT CUE POINTS TO THE ST300,**” Section 12.a.1).

## **b. RECEIVE CUE LIST FUNCTION**

The RECEIVE CUE LIST function allows you to receive your list of Cue Points from a PC or from another ST300. Transfer to a PC requires OpSuite 3.0 software, which runs on a Windows-based computer. Contact DNF Controls for more information.

### **1) TO RECEIVE CUE POINTS FROM THE ST300**

- a) Connect the VTR4 connector on the back of the ST300 from the VTR4 connector of the transmitting ST300 using RS422 9-pin cable with TX and RX lines crossed. (A “Turnaround” Cable)
- b) Press **[MENU]**.
- c) Scroll the wheel until “Receive CUE List? YES=Enter, Exit=ESC” is displayed.
- d) Press **[ENTER]** to start receiving.  
The Display shows “Waiting to receive” on the first line.
- e) When the Transmitter is ready, transfer starts automatically.  
The display now shows “Receiving cuelist.”
- f) After the transfer is over the display shows “Done-Success! Press any key...”
- g) Press any key. The display shows “Receive cuelist?” message.
- h) Press **[ESC]** to exit the MENU mode.

### **2) TO RECEIVE CUE POINTS FROM THE PC**

- a) Connect the VTR4 connector on the back of the ST300 to one of the COM ports on the PC using RS422 to RS232 adapter
- b) Repeat steps b – h of “**TO RECEIVE CUE POINTS FROM THE ST300,**” Section 12.b.1).

## Reference . . .

### 13. SETUP MENU

Press [MENU]. The MENU indicator will turn on.

Turn the Wheel to select item to change.

Press [MENU] **OR** use the Softkeys to change the desired mode for that option.

Turn the Wheel at anytime to select another item.

Press [ESC] at anytime to exit SETUP MENU. The MENU indicator will turn off.

<u>MENU MODES</u>	<u>(Turning Wheel clockwise)</u>
<b>SET LOUTH PORT</b>	Allows user to select Louth Port for each VTR. Using the numeric key pad, enter the LOUTH Port number for the video server channel to be controlled.  Press [ENTER] to select an INPUT channel. <b>OR</b> Press [ESC] to select an OUTPUT channel
<b>RECORD MODE</b>	Press [MENU] to select the desired record mode: Lockout, Crash (Full).
<b>EXTENDED IDs</b>	Toggle the softkey to turn Extended IDs ON. (Support up to 32-character Clip IDs.) <b>OR</b> OFF (Support up to 8-character Clip IDs.)
<b>CLIP SOM</b>	Press displayed softkey to toggle between “ZERO” and “NOT ZERO.”  Select ZERO if the clips that you are using start with 00:00:00:00.  Select NOT ZERO if the clips that you are using do not start with 00:00:00:00.
<b>RECALL MODE</b>	Press Normal or Redirect (Redir). When one and only one clip is learned into a Cue Point, the Clip will be REDIRECTED to load on the currently selected VTR if REDIR is on.  If REDIR is off, the Clip will be loaded on the VTR it is LEARNED into.
<b>VIDEO STANDARD</b>	Press displayed softkey to select PAL, NTSC (non drop frame), or DF (drop frame).

<b>WIND MODE</b>	<p>Press Softkey to select:</p> <p><b>[HOLD]</b> Fast wind is maintained only while key is depressed.  <b>OR</b></p> <p><b>[LATCH]</b> Fast wind is initiated and maintained with momentary key press.</p> <p>Press the <b>[SPD]</b> softkey to step through the list of available wind speeds and select a speed.</p>				
<b>SLOMO</b>	<p>ST300 display shows:</p> <table border="1" data-bbox="839 537 1356 661"> <tr> <td>SLOMO with:</td> <td>WHEEL</td> </tr> <tr> <td>Speed</td> <td>Prset</td> </tr> </table> <p>Press Softkey <b>[SPEED]</b> to select SLOMO speed ranges:  Press Softkey to select: 0 → +200 <b>OR</b> -100 → +200.</p> <p>Press Softkey <b>[BACK]</b> to return to SLOMO MENU.</p> <p>Press <b>[ESC]</b> to exit SETUP MENU.  <b>OR</b></p> <p>Turn the Wheel to select another item.</p> <p><b>For Wheel only:</b>  Press Softkey <b>[PRSET]</b> to select the SLOMO Preset Speed Mode.</p> <p>Press Softkey <b>[UPDATE]</b>. When exiting SLOMO mode, the last used speed is saved in the Preset Speed register.</p> <p>Press Softkey <b>[STATIC]</b>. The Preset Speed register is NOT updated when exiting SLOMO mode. It is only changed by <b>[SHIFT] + [SLOMO]</b> (PRESET SLOMO).</p>	SLOMO with:	WHEEL	Speed	Prset
SLOMO with:	WHEEL				
Speed	Prset				
<b>ST300 SETUP</b>	<table border="1" data-bbox="724 1346 1240 1476"> <tr> <td colspan="2">ST300 SETUP</td> </tr> <tr> <td>Clear Cues</td> <td>SetDefault</td> </tr> </table> <p>Press Softkey beneath ClearCues to clear all Cue Points to 00:00:00:00.  Press Softkey <b>[YES]</b> when asked “Are You Sure?”</p> <p>Press Softkey beneath SetDefault to set ST300 to default settings.  Press Softkey <b>[YES]</b> when asked “Are You Sure?”</p>	ST300 SETUP		Clear Cues	SetDefault
ST300 SETUP					
Clear Cues	SetDefault				
<b>DISPLAY SOFTWARE VERSION</b>	<p>The version number for the currently installed software is displayed.</p>				

<b>SYNC</b>	Toggle the softkey to enable/disable reference Video.
<b>RECORD</b>	Press Softkey to select single button or 2-button record. RECORD = [REC] Only. <b>OR</b> RECORD = [REC] + [PLAY]
<b>PREROLL</b>	Enter Preroll value.
<b>TRANSMIT CUELIST</b>	Allows user to transfer Cuelist to another ST300 or a PC.
<b>RECEIVE CUELIST</b>	Allows user to receive a Cuelist from another ST300 or a PC.

## 14. FUNCTION TABLE

Function	Key Press	Description
ENTER RECORD LENGTH	[SHIFT] + [RECORD]	Enter the desired record length using the numeric keypad. Press [ENTER] to accept.
FFWD	[FFWD]	Press and HOLD to shuttle. Release key to stop. Set WIND Speed in MENU.
GANG	[SHIFT] + [VTR #1] OR [SHIFT] + [VTR #2] OR [SHIFT] + [VTR #3] OR [SHIFT] + [VTR #4]	Individually press the VTR keys to be included in the gang; the LED above the key will turn on. Press the VTR key again to remove from gang; the LED above the key will turn off. Press [ESC] to exit.  The VTR LEDs that are on show the gang. The flashing LED shows which VTR is currently selected.
GO TO ENTERED TIME	[SHIFT] + [RECUE]	Enter the desired recue time using the numeric keypad. Press [ENTER] or [RECUE] to reload the currently loaded clip at the entered time.
JOG	[JOG]	Select JOG mode and enable Wheel.
LAST CUE	[LAST CUE]	Step to the previous Cue Point Location.
NEXT CUE	[NEXT CUE]	Step to the next Cue Point Location.
RECORD	[REC]	Places VTR into the Record mode selected by RECORD MODE in the SETUP MENU. Press [RECORD] or [RECORD] + [PLAY].
REWIND	[RWD]	Press and HOLD to shuttle. Release key to stop. Set WIND Speed in MENU.
SHUTTLE	[SHUTTLE]	Select SHUTTLE mode and enable Wheel.
SLOMO	[SLOMO]	Press [SLOMO] to slo-mo the VTR. Turn the Wheel to change the play speed. Press [SLOMO] to STILL the frame. <b>OR</b> Press any transport key to exit SLOMO.
SLO-MO SPEED PRESET	[SHIFT] + [SLOMO]	For WHEEL ONLY: Press [SHIFT] + [SLOMO] to preset the slo-mo speed. Turn the Wheel to select desired speed. Press [ESC] or any transport key to exit.
STOP	[STOP]	Press once to STILL frame VTR.
TIME MODE SELECT	[TIME MODE]	Press to toggle between: Remaining time (RT) <b>OR</b> Elapsed time (ET).

## 15. SPECIFICATIONS

### ST300

Power:	90 VAC to 265 VAC adapter supplied with IEC connector.		
Size:	(L" x W" x H") 12" x 6" x 1.5" (front) 3.0" (rear) (T-Bar unit is 12.6" long)		
Weight:	4 lbs.		
Rear Panel Connectors:	VTR1, VTR2, VTR3, VTR4	(All DB9F)	
	GPI	(DBF15F)	
	Power	(DB9M)	
	Aux	(DB9F)	
	Reference Video	(BNC)	
Display:	Easy to read 2-line, back-lit LCD display (User adjustable contrast)		
Jog/Shuttle Wheel:	With mechanical detents.		
Optional "T"-bar:	Slo-mo 0-200% of Play Speed		

### VTR RS422 SERIAL CONNECTOR

#### 9-Pin D-Type, Female

Pin #	1	Frame Ground	6	Receive Common
	2	Receive A ←	7	Receive B ←
	3	Transmit B →	8	Transmit A →
	4	Transmit Common	9	Frame Ground
	5	Spare		

### POWER CONNECTOR

#### 9-Pin D-Type, Male

Pin #	1	+5v DC	6	+5 VDC
	2	+5v DC	7	Ground
	3	Ground	8	Ground
	4	+12 VDC	9	Ground
	5	-12 VDC		

## AUX PORT RS422 SERIAL CONNECTOR

### 9-Pin D-Type, Female

Pin #	1	Frame Ground	6	Receive Common
	2	Receive A ←	7	Receive B ←
	3	Transmit B →	8	Transmit A →
	4	Receive Common	9	Frame Ground
	5	Spare		

## GPI IN/OUT CONNECTOR

### 15-Pin D-Type, Female (DB15F)

Pin #	Description	Function	Pin #	Description	Function
1	GPI 1 Out		9	GPI 1 In	Play
2	GPI 2 Out		10	GPI 2 In	Stop
3	GPI 3 Out		11	GPI 3 In	Recue
4	GPI 4 Out		12	GPI 4 In	Next Cue
5	GPI 5 Out		13	GPI 5 In	Last Cue
6	GPI 6 Out		14	GPI 6 In	Recall
7	GPI 7 Out		15	GPI 7 In	
8	Ground				

# 16. KEY LAYOUT

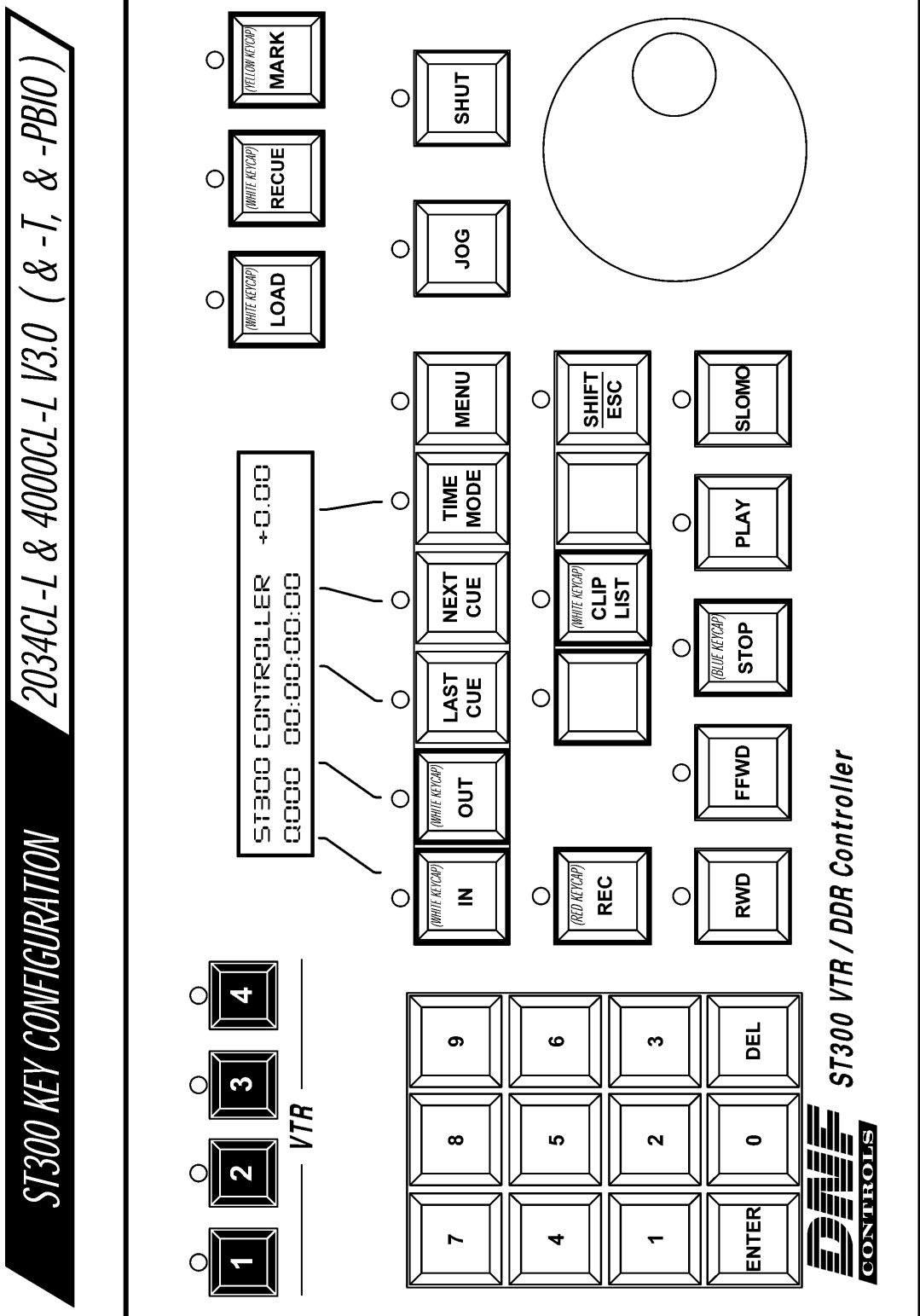

## **17. DNF CONTROLS LIMITED WARRANTY**

DNF Controls warrants its product to be free from defects in material and workmanship for a period of one (1) year from the date of sale to the original purchaser from DNF Controls.

In order to enforce the rights under this warranty, the customer must first contact DNF's Customer Support Department to afford the opportunity of identifying and fixing the problem without sending the unit in for repair. If DNF's Customer Support Department cannot fix the problem, the customer will be issued a Returned Merchandise Authorization number (RMA). The customer will then ship the defective product prepaid to DNF Controls with the RMA number clearly indicated on the customer's shipping document. The merchandise is to be shipped to:

DNF Controls  
12843 Foothill Blvd., Suite D  
Sylmar, CA 91342  
USA

Failure to obtain a proper RMA number prior to returning the product may result in the return not being accepted, or in a charge for the required repair.

DNF Controls, at its option, will repair or replace the defective unit. DNF Controls will return the unit prepaid to the customer. The method of shipment is at the discretion of DNF Controls, principally UPS Ground for shipments within the United States of America. Shipments to international customers will be sent via air. Should a customer require the product to be returned in a more expeditious manner, the return shipment will be billed to their freight account.

This warranty will be considered null and void if accident, misuse, abuse, improper line voltage, fire, water, lightning or other acts of God damaged the product. All repair parts are to be supplied by DNF Controls, either directly or through its authorized dealer network. Similarly, any repair work not performed by either DNF Controls or its authorized dealer may void the warranty.

After the warranty period has expired, DNF Controls offers repair services at prices listed in the DNF Controls Price List. DNF Controls reserves the right to refuse repair of any unit outside the warranty period that is deemed non-repairable.

DNF Controls shall not be liable for direct, indirect, incidental, consequential or other types of damage resulting from the use of the product.

###