



12843 Foothill Blvd. Suite C
Sylmar, California 91342
V: 818.898.3380
F: 818.898.3360
sales@dnfcontrols.com

Model No. 2MCE-24P

**Two Machine, Cuts Only Editor
With 24P Editing Capability**

USER MANUAL

Table of Contents

1.	REVISION HISTORY	3
<i>GETTING STARTED...</i>		4
2.	DESCRIPTION	4
	STANDARD FEATURES	4
	DEFINITIONS	4
3.	INSTALLATION	5
	A. ST300-S/SM, VTR/DDR CONTROLLER	5
	B. SELECT RECORDER	5
	C. SELECT PLAYER	5
	D. REFERENCE VIDEO INPUT	5
	E. SET THE VTR'S COLOR FRAME MODE	5
	F. SET THE RECORD DELAY	6
	G. SET THE RECORD MODE	6
	H. SET THE VIDEO STANDARD	6
	I. SET PREROLL VALUE	6
4.	OPERATION	8
	A. TRIM AN IN/OUT POINT	8
	B. CLEAR AN OUT POINT	8
	C. GOTO IN/OUT POINTS	8
	D. CRASH RECORD	8
	E. PERFORM AN EDIT	9
	F. PERFORM AN OFF SPEED EDIT	10
	G. PREVIEW AN EDIT	11
	H. REVIEW AN EDIT	11
	I. ONE MACHINE AUTOEDIT	12
	J. ONE MACHINE AUODOEDIT PREVIEW FUNCTION	13
<i>REFERENCE...</i>		14
5.	SETUP MENU	14
6.	FUNCTION TABLE	16
7.	SPECIFICATIONS	17
	RS422 SERIAL CONNECTOR	17
	POWER CONNECTOR	17
	GPI IN/OUT CONNECTOR	17
8.	KEY LAYOUT	18
9.	DNF CONTROLS LIMITED WARRANTY	19

Manual Version 1.1 112103
Document ID MCE-24P_User_Manual.doc

1. REVISION HISTORY

100903 1.0 Original document.

112103 1.1 Added DNF Controls Limited Warranty.

Getting Started . . .

2. DESCRIPTION

The 2MCE-24P is a two machine Cuts Only editor with the ability to perform 24P edits for HD media.

- ❑ Fast, easy to use, news-style editing.
- ❑ Easy to read 4-line display quickly shows in, out and duration.
- ❑ Numeric keypad provides quick and easy entry of in, out and duration.
- ❑ Performs off speed Edits. Change Source speed during edit.
- ❑ Hot punch Video and Audio channels during edit.

STANDARD FEATURES

Record, Edit, Play, Stop, Rewind, Fast Forward, Jog, Shuttle, Preroll, GoTo, Trim +, Trim -, Clear OUT Point, Preview, Review, Off Speed Edit.

Video Reference input provides frame accurate edits.

Set IN & OUT points by manually entering desired time.

OR

By MARKing tape location.

Trim + and TRIM - keys and numeric keypad provide a fast and easy way to trim IN and OUT times. Trim by frames, second, minutes or hours.

Easy to perform off speed edits: Select source playback speed, Set Source IN point, Set Recorder IN and OUT point. Perform the edit.

Change Source speed during edit.

During INSERT recording, hot punch

Video, Audio1, Audio2, Audio3 & Audio 4

Punch In or Punch Out

Optional 7 GPI Inputs and 7 GPI Outputs.

DEFINITIONS

- ❑ Throughout this document VTR, DDR, VDR & Video Server will be referred to collectively as “VTR.”
- ❑ The Two Machine Cuts only Editor will be referred to as the 2MCE.
- ❑ Words surrounded by brackets, for example, [ENTER], are keys on the ST300.
- ❑ [XXX] + [XXX] means hold the two keys down simultaneously.
- ❑ The 5 “SOFTKEYS” are located just below the Display.

3. INSTALLATION

a. ST300-S/SM, VTR/DDR CONTROLLER

- 1) Plug one end of a 9-conductor, RS422 serial cable into the 9-pin connector (VTR1, VTR2, VTR3 or VTR4) on the rear of the ST300. Plug the other end of the cable into the 9-pin remote connector on the Video Server.
- 2) Connect the +5, +12, -12 VDC POWER SUPPLY into the POWER connector on the rear of the ST300. Plug the Power Supply into a wall outlet, 90 VAC to 240 VAC.
- 3) Check SETUP MENU prior to using the ST300 to confirm proper Record mode and other User settable modes.

b. SELECT RECORDER

Press [SHIFT] + [VTR1], [SHIFT] + [VTR2], [SHIFT] + [VTR3], or [SHIFT] + [VTR4] to select the RECORDER. The VTR's LED will flash.

c. SELECT PLAYER

Press [VTR1], [VTR2], [VTR3] or [VTR4] to select the PLAYER. The VTR's LED will turn on.

NOTE: Selecting a PLAYER VTR will automatically put the RECORDER VTR into EE mode. The selected PLAYER VTR indicator will turn on and remains on when the RECORDER is selected.

d. REFERENCE VIDEO INPUT

Connect Black Video or the Tri-level Sync (for 24P editor) to the Reference Video BNC on the rear of the 2MCE.

NOTE - [The ST300 will allow edits without sync.](#)

e. SET THE VTR'S COLOR FRAME MODE

- 1) [Set the color frame on the RECORD DECK to: ON](#)
- 2) [Set the color frame on the PLAYBACK to: OFF](#)
- 3) Set the VTRs Capstan Lock. Set Capstan Lock on the Recorder to "2FD."

f. SET THE RECORD DELAY

- 1) Press [MENU]. The MENU key indicator will turn on.
- 2) Turn the wheel until “RECORD DELAY=” is displayed.
- 3) Enter Record Command latency (delay) time in frames using the numeric keypad.
(Typical value for SONY BVW75 is 3 frames.)
- 4) Press [ESC] to exit the SETUP MENU.
The MENU key indicator will turn off.

g. SET THE RECORD MODE

- 1) Press [MENU]. The MENU key indicator will turn on.
Turn the wheel until “REC: =” is displayed.
- 2) Press [MENU] to toggle between LOCKOUT, ASSEMBLE, CRASH and INSERT record modes.
- 3) In INSERT mode, press the “SOFTKEYS” to select Video, Audio1, Audio2, Audio3 or Audio4.

NOTE: The 5 “SOFTKEYS” are located just below the Display.

- 4) Press [ESC] to exit the setup menu. Indicator will turn off.

h. SET THE VIDEO STANDARD

- 1) Press [MENU]. The menu indicator will turn ON.
- 2) Turn the wheel until “Video Standard:” is displayed.
- 3) Press the softkey (a key underneath the desired standard: 24P, NTSC or PAL) to select a video standard to perform edits in.
- 4) Press [ESC] to exit the setup menu.

i. SET PREROLL VALUE

1. Press [SHIFT] + [PREROLL]. The display will show the current Preroll Value.
2. Enter the desired Preroll Value using the numeric keypad. The display will show the entered value.
3. Press [PREROLL] to save the current value and exit.
OR
Press [ESC] to exit without saving.

Installation is complete.

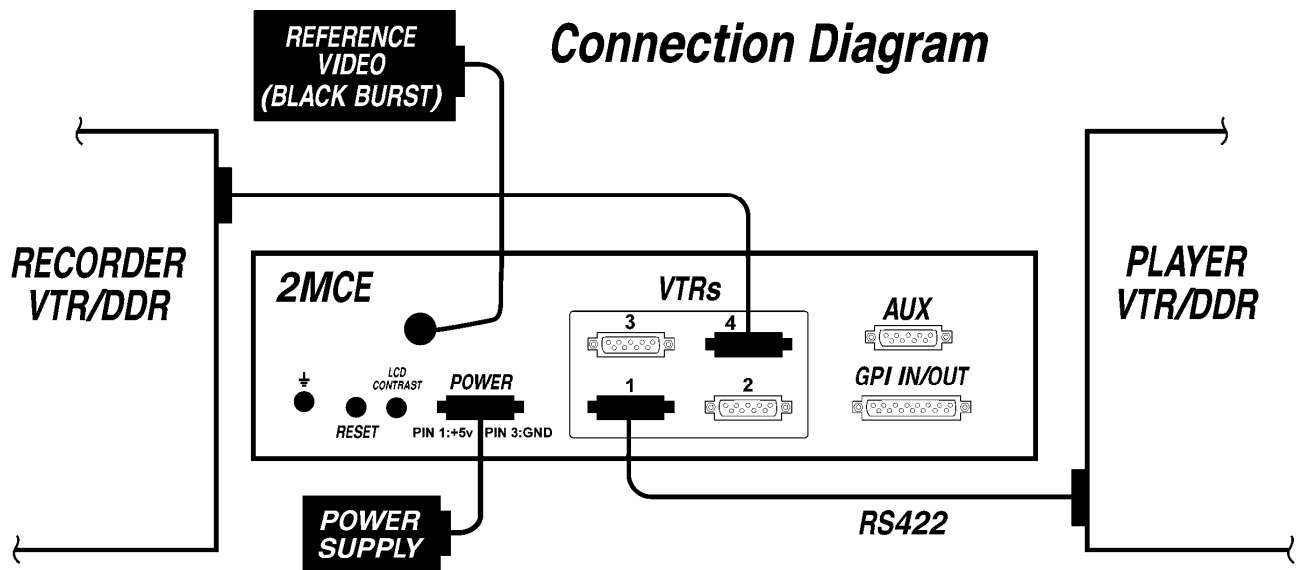

4. OPERATION

a. TRIM AN IN/OUT POINT

- 1) Press [TRIM+] or [TRIM-].
The display will prompt "Enter Time, Select IN/OUT."
- 2) Enter the amount of trim using the numeric keypad.
The top row of the display will show the entered amount.
- 3) Press [IN] to trim the IN Point.
Press [OUT] to trim the OUT Point.
The trimmed time will be displayed on the bottom row of the display.

b. CLEAR AN OUT POINT

Press [CLR OUT] to clear the OUT point.
The OUT key indicator will turn off.
The OUT Point on Recorder and Player will be cleared to 00:00:00:00.

c. GOTO IN/OUT POINTS

- 1) Press [GOTO]. The GOTO key Indicator will turn on.
- 2) The display will prompt for IN or OUT.
- 3) Press [IN] to goto the IN Point.
Press [OUT] to goto the OUT Point.
OR
Press [ESC] to exit without searching.

d. CRASH RECORD

NOTE: Check the Record option in the Setup Menu. It should be set to Crash Record.

- 1) Select the Recorder.
- 2) Press [SHIFT] + [RECORD] if the option in the Setup Menu is set to Rec only.

Press [RECORD] + [PLAY] if the option in the Setup Menu is set to Rec + Play.
The record VTR will begin recording immediately.
There is no preroll in the Crash Record mode.
The RECORD key indicator will turn on.
- 3) Press [STOP] to end recording. RECORD indicator turns off.

e. **PERFORM AN EDIT**

- 1) Select the PLAYER VTR.
- 2) Set the IN point by manually entering a time using the numeric keyboard.
OR
By pressing [IN] and marking the current tape time.
- 3) Set OPTIONAL OUT point using the same procedure as IN.
OR
Set the OPTIONAL OUT point by pressing [SHIFT] ± [OUT].
The display will show the current PLAYER duration.
Manually enter the desired duration using the numeric keypad.
Press [OUT] to save the entered duration.
OR
Press [ESC] to exit without saving the entered duration.
- 4) Select the RECORDER.
- 5) Set the IN point by manually entering a time using the numeric keyboard.
OR
By pressing [IN] and marking the current tape time.
- 6) Press [PREVIEW] to preview the edit.
- 7) Press [REC] to perform the edit.
The RECORDER and PLAYER will preroll, then synchronize.
At the IN point, the RECORDER will go into record.
At the OUT time, the RECORDER will terminate record.
- 8) During the edit, in INSERT mode, press the Softkeys to punch desired channels into and out of record.
- 9) Press [STOP] at anytime to abort the edit.
OR
For OPEN-ENDED edits, press [OUT] to terminate the edit.
- 10) Upon successfully completing the edit,
The RECORDER IN Point will be set to the record out time.
The PLAYER IN Point will be set to the PLAYER out time.
The RECORDER and PLAYER will cue to their respective IN times and park.

NOTE: Prior to performing an Edit, the time type of the IN and OUT are checked. If they are not both Tape Time or Time Code, an Error message is displayed and the Edit is aborted.

f. PERFORM AN OFF SPEED EDIT

- 1) Select the PLAYER VTR.
- 2) Press **[OFF SPEED]**. The OFF SPEED indicator will turn on.
(Press **[OFF SPEED]** again to disable off speed edit.)
- 3) Turn the wheel to select the PLAYER's playback speed.
Select +0.00 for STILL frame.
(To slo-mo the VTR and select a slo-mo speed, press **[SHIFT]** + **[OFF SPEED]**. Turn the wheel. Press **[STOP]** when done.)
- 4) Set the IN point by manually entering a time using the numeric keyboard.
OR
By pressing **[IN]** and marking the current tape time.
- 5) The PLAYER OUT Point is ignored.
- 6) Select the RECORDER.
- 7) Set the IN point by manually entering a time using the numeric keyboard.
OR
By pressing **[IN]** and marking the current tape time.
- 8) Set the optional OUT Point by manually entering a time, using the numeric keyboard.
OR
By pressing **[OUT]** and marking the current tape time.
OR
By pressing **[SHIFT]** + **[OUT]**.
The display will show the current RECORDER duration.
Manually enter the desired duration using the numeric keypad.
Press **[OUT]** to save the entered duration.
OR
Press **[ESC]** to exit without saving the entered duration.
- 9) Press **[REC]** to perform the edit.
The PLAYER will cue to the IN time.
The RECORDER will preroll.
The PLAYER will Slo-Mo at the selected speed.
The RECORDER will go into play.
At the IN point, the RECORDER will go into record.
At the OUT time, the RECORDER will terminate record.
During the Edit, turn the wheel to change the Slo-Mo speed.
- 10) During the edit in INSERT mode,
Press the Softkeys to punch desired channels into and out of record.

- 11) [Press \[STOP\] at anytime to abort the edit.](#)
- 12) [For OPEN-ENDED edits, press \[OUT\] to terminate the edit.](#)
- 13) [Upon successfully completing the edit:
The RECORDER IN Point will be set to the record out time.
The RECORDER VTR will cue to its IN_Time.](#)
- 14) Press [OFF SPEED] to disable off speed edit. The SLOMO key indicator will turn off.

g. PREVIEW AN EDIT

NOTE: PREVIEW and REVIEW functions apply to INSERT and ASSEMBLE edit modes **only**.

- 1) [Press \[PREVIEW\] to preview the edit.
The PREVIEW key indicator will turn on.](#)
- 2) [At the IN point, the record ready channels will go into EE mode.
At the OUT point, the record ready channels will go to playback mode.](#)
- 3) [Press \[STOP\] at anytime to abort Preview.](#)
- 4) [Upon completion, the PREVIEW key indicator will turn off.](#)

h. REVIEW AN EDIT

Review mode is only available after a successful edit has been completed.

- 1) [Press \[REVIEW\] to review the previous edit.
The REVIEW key indicator will turn on.](#)
- 2) [The RECORDER will preroll to the original IN point, then play the edit.
At the OUT point, the RECORDER will post roll 2 seconds, then stop.](#)
- 3) [Press \[STOP\] at any time to abort Review.
The REVIEW key indicator will turn off.](#)

i. ONE MACHINE AUTOEDIT

- 1) Select the RECORDER VTR.
Record mode must be Assemble or Insert.
- 2) Set the IN point by manually entering a time using the numeric keyboard.
OR
By pressing [**IN**] and marking the current tape time.
- 3) Set OPTIONAL OUT point using the same procedure as IN.
OR
Set the OPTIONAL OUT point by pressing [**SHIFT**] + [**OUT**].
The display will show the current PLAYER duration.
Manually enter the desired duration using the numeric keypad.
Press [**OUT**] to save the entered duration.
OR
Press [**ESC**] to exit without saving the entered duration.
- 4) Press [**AUTOEDIT**].
The recorder will preroll to the IN point.
The second line of the display will say "Prerolling---."
The recorder will be put into PLAY mode.
At the IN Point, the recorder will go into Record.
The second line of the display shows "AUTO EDIT."
At the OUT point, the recorder goes out of Record and does a 2-second postroll,
then goes into STOP mode.
- 5) Press [**STOP**] at anytime to abort the autoedit.

j. ONE MACHINE AUDEDIT PREVIEW FUNCTION

- 1) Select Recorder VTR.
Record mode must be Assemble or Insert.
- 2) Set the IN point by manually entering a time using the numeric keyboard.
OR
By pressing [**IN**] and marking the current tape time.
- 3) Set OPTIONAL OUT point using the same procedure as IN.
OR
Set the OPTIONAL OUT point by pressing [**SHIFT**] + [**OUT**].
The display will show the current PLAYER duration.
Manually enter the desired duration using the numeric keypad.
Press [**OUT**] to save the entered duration.
OR
Press [**ESC**] to exit without saving the entered duration.
- 4) Press [**SHIFT**] + [**AUTOEDIT**].
The machine will preroll to the IN Point.
The second line of the display will show "Prerolling---."
The machine will go into PLAY mode.
At the IN point, the record ready channels will go into EE mode.
The second line of the display shows "Autoedit---."
At the OUT Point, the record ready channels will go into playback mode.
- 5) Press [**STOP**] at anytime to abort the Preview.

Reference . . .

5. SETUP MENU

- ❑ Press [MENU]. The MENU indicator will turn on. Turn the Wheel to select item to change.
- ❑ Press [ESC] at anytime to exit **SETUP MENU**. The MENU indicator will turn off.

<u>MENU MODES</u>	<u>(Turning Wheel clockwise)</u>
RECORD MODE	Press [MENU] to select the desired record mode: Lockout, Crash (Full). <u>Only</u> in INSERT mode: Press the associated Softkey, located below the display, to toggle Video(V), Audio1(A1), Audio2(A2), Audio3(A3), Audio4(A4) on/off.
SLOMO SPEED RANGE	Press [MENU] to select the desired speed range: -100 → +200 or 0 → +200
SLOMO PRESET	Press [MENU] to select the desired mode: UPDATE or STATIC UPDATE - When exiting OFFSPEED mode, the last used speed is saved in the Preset Speed register. STATIC - The Preset Speed register is NOT updated when the wheel is turned. Upon entering OFFSPEED mode, the slomo speed is always restored to the preset value set by [SHIFT] + [SLOMO].
MAX WIND SPEED	Press [MENU] to select the desired maximum wind speed.
WIND MODE	Press [MENU] to select the desired wind mode, LATCH or HOLD. LATCH - Fast wind is initiated and maintained with a momentary key press. HOLD - Fast wind is initiated and maintained only while key is pressed. Upon releasing key, wind mode terminates.
VIDEO STANDARD	Press a Softkey to select the desired video standard – PAL, NTSC or 24P.
RECORD	Press Softkey to select single button or 2-button record. RECORD = [REC] Only OR RECORD = [REC] + [PLAY]
DISPLAY SOFTWARE VERSION	The version number for the currently installed software is displayed.
CLEAR MEMORY	Press [DEL] to clear the controller's internal memory. Press [ESC] to exit without clearing memory.
SET FACTORY DEFAULTS	Press [DEL] to initialize the controller to factory defaults. Press [ESC] to exit without initializing controller to factory defaults.

TCSOURCE	Press [MENU] to select RECORDER or PLAYER as time source during edit. RECORDER is default and recommended setting.
EDIT MODE	<p>Press [MENU] to select the EDIT MODE - MODE1 or MODE2.</p> <p>MODE1 - All IN & OUT marks will use Timecode as time type regardless of the TIME MODE selection.</p> <p>MODE2 - The currently selected TIME MODE will be used when marking IN & OUT.</p>
RECORD DELAY	Manually enter the VTR Manufacturer's record latency in frames (0 -99).

6. FUNCTION TABLE

Function	Key Press	Description
AUTOEDIT	[AUTOEDIT]	Set IN time and (Optional) OUT Time. Press [AUTOEDIT] and Recording VTR/DDR performs an Autoedit using Assemble or Insert recording.
AUTOEDIT PREVIEW	[SHIFT] + [AUTOEDIT]	Set IN time and (Optional) OUT Time. Press [AUTOEDIT] + [SHIFT] and Recording VTR/DDR performs a preview of the Autoedit.
FFWD	[FFWD]	Press and HOLD to shuttle. Release key to stop. Set WIND Speed in MENU.
GOTO In or OUT	[GOTO]	Search the VTR to the contents of the currently displayed IN or OUT point or entered time.
JOG	[JOG]	Select JOG mode and enable the Wheel.
OFFSPEED PLAYBACK	[SHIFT] + [OFFSPEED]	Play offspeed. Turn wheel to change speeds.
PREROLL	[PREROLL]	Preroll the VTR to the contents of the currently displayed Cue Point.
PREROLL VALUE	[SHIFT] + [PREROLL]	Enter desired Preroll Value. Press [ENTER] to save entry OR press [ESC] to exit without saving entry.
RECORD	[SHIFT] + [REC]	Places VTR in the Record mode selected by RECORD MODE in the SETUP MENU. One button record.
RESET TAPE TIME	[DEL] + [TIME MODE]	Reset the Tape Time to 00:00:00:00 on the currently selected VTR.
REWIND	[RWD]	Press and HOLD to shuttle. Release key to stop. Set WIND Speed in MENU.
SHUTTLE	[SHUTTLE]	Select SHUTTLE mode and enable the Wheel.
STOP	[STOP]	Press once to STILL frame VTR. Press again to put VTR into STOP mode.
TIME MODE SELECT	[TIME MODE]	Press to toggle between Timecode (TC), VITC (VT) or Tape Timer (TM) display modes.
TIME PRESET (Generator Preset)	[SHIFT] + [TIME MODE]	Press to enter Time Preset. Press [ENTER] to load Time Generator OR press [ESC] to exit without saving.

7. SPECIFICATIONS

Power	90 VAC to 265 VAC adapter supplied with IEC connector
Size	[L" x W" x H"] 12" x 6" x 1.5" (front) 3.0" (rear)
Weight	4 lbs.
Real Panel Connectors	VTR1, VTR2, VTR3, VTR4 (All DB9F) GPI (DBF15F) Power (DB9M) Aux (DB9F)
Display:	Easy to read 4-line, back-lit LCD display (User adjustable contrast)
Jog/Shuttle Wheel	With mechanical detents.

RS422 SERIAL CONNECTOR

9-Pin D-Type, Female (DB9F)

Pin #	1	Frame Ground	6	Receive Common
	2	Receive A ←	7	Receive B ←
	3	Transmit B →	8	Transmit A →
	4	Transmit Common	9	Frame Ground
	5	Spare		

POWER CONNECTOR

9-Pin D-Type, Male (DB9M)

Pin #	1	+5v DC	6	+5 VDC
	2	+5v DC	7	Ground
	3	Ground	8	Ground
	4	+12 VDC	9	Ground
	5	-12 VDC		

GPI IN/OUT CONNECTOR

15-Pin D-Type, Female (DB15F)

Pin #	1	GPI 1 Out	Pin #	9	GPI 1 In
	2	GPI 2 Out		10	GPI 2 In
	3	GPI 3 Out		11	GPI 3 In
	4	GPI 4 Out		12	GPI 4 In
	5	GPI 5 Out		13	GPI 5 In
	6	GPI 6 Out		14	GPI 6 In
	7	GPI 7 Out		15	GPI 7 In
	8	Ground			

8. KEY LAYOUT

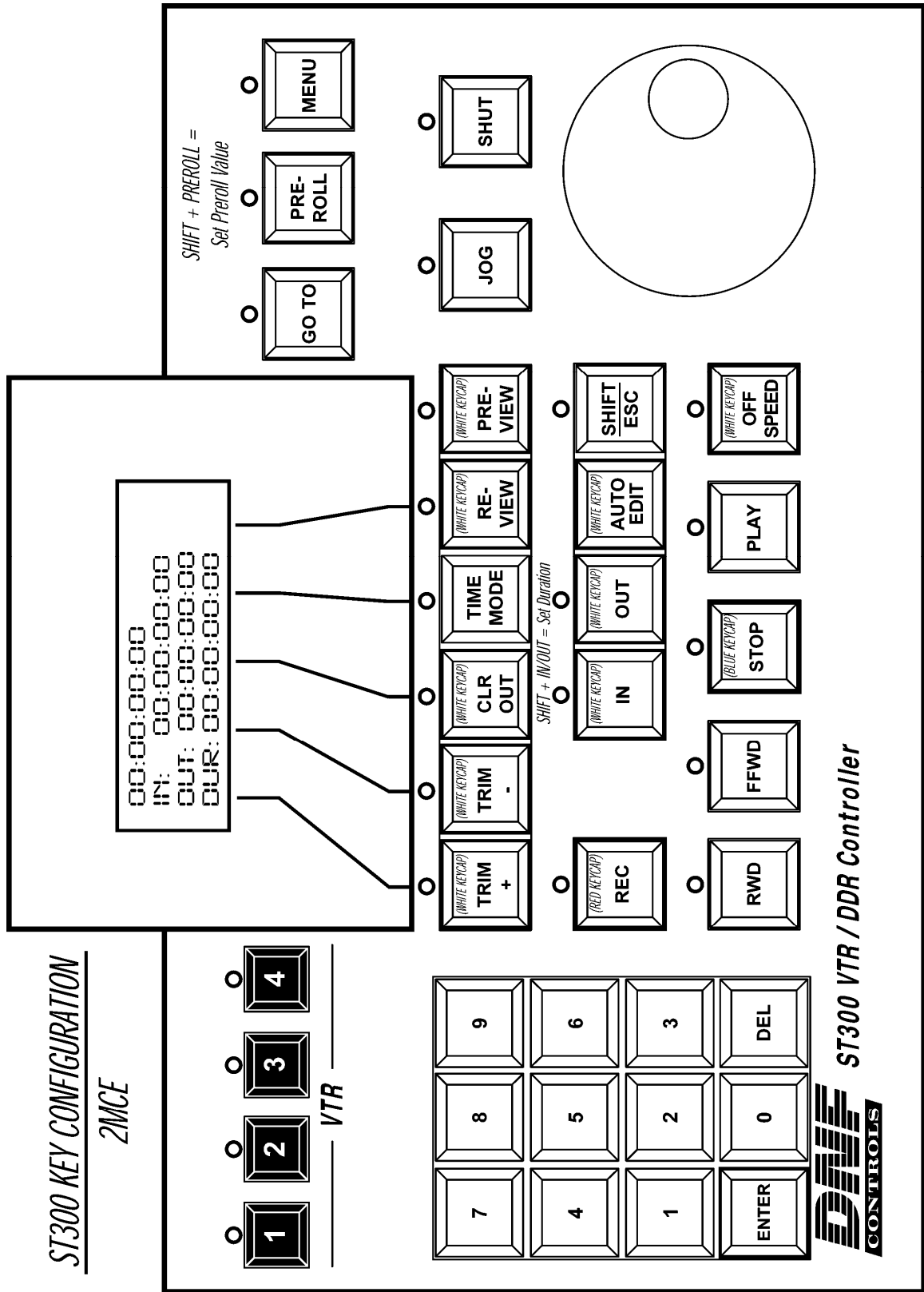

9. DNF CONTROLS LIMITED WARRANTY

DNF Controls warrants its product to be free from defects in material and workmanship for a period of one (1) year from the date of sale to the original purchaser from DNF Controls.

In order to enforce the rights under this warranty, the customer must first contact DNF's Customer Support Department to afford the opportunity of identifying and fixing the problem without sending the unit in for repair. If DNF's Customer Support Department cannot fix the problem, the customer will be issued a Returned Merchandise Authorization number (RMA). The customer will then ship the defective product prepaid to DNF Controls with the RMA number clearly indicated on the customer's shipping document. The merchandise is to be shipped to:

DNF Controls
12843 Foothill Blvd., Suite C
Sylmar, CA 91342
USA

Failure to obtain a proper RMA number prior to returning the product may result in the return not being accepted, or in a charge for the required repair.

DNF Controls, at its option, will repair or replace the defective unit. DNF Controls will return the unit prepaid to the customer. The method of shipment is at the discretion of DNF Controls, principally UPS Ground for shipments within the United States of America. Shipments to international customers will be sent via air. Should a customer require the product to be returned in a more expeditious manner, the return shipment will be billed to their freight account.

This warranty will be considered null and void if accident, misuse, abuse, improper line voltage, fire, water, lightning or other acts of God damaged the product. All repair parts are to be supplied by DNF Controls, either directly or through its authorized dealer network. Similarly, any repair work not performed by either DNF Controls or its authorized dealer may void the warranty.

After the warranty period has expired, DNF Controls offers repair services at prices listed in the DNF Controls Price List. DNF Controls reserves the right to refuse repair of any unit outside the warranty period that is deemed non-repairable.

DNF Controls shall not be liable for direct, indirect, incidental, consequential or other types of damage resulting from the use of the product.

###