



12843 Foothill Blvd. Suite C
Sylmar, California 91342
V: 818.898.3380
F: 818.898.3360
sales@dnfcontrols.com

Model No. DMAT-MAV

USER MANUAL

Table of Contents

| SECTION | CONTENTS | PAGE |
|------------------------------|-------------------------------------|-------------|
| 1. | REVISION HISTORY | 3 |
| 2. | DESCRIPTION..... | 3 |
| <i>Getting Started . . .</i> | | |
| 3. | INSTALLATION..... | 5 |
| 4. | GETTING STARTED..... | 7 |
| 5. | SETUP MENU..... | 9 |
| | A. Record..... | 10 |
| | B. Set & Clear..... | 11 |
| 6. | OPERATIONS..... | 20 |
| | A. Creating a Playlist..... | 21 |
| | B. Effects | 23 |
| <i>Reference . . .</i> | | |
| 7. | FUNCTION TABLE..... | 25 |
| 8. | SPECIFICATIONS..... | 26 |
| 9. | KEY LAYOUT | 28 |
| 10. | DNF CONTROLS LIMITED WARRANTY | 29 |

Manual Version:.....4.3 120103
Document ID:.....DMAT-MAV_User_Manual

1. REVISION HISTORY

120103 Rev. 4.3 Company header information revised.
Added DNF Controls Limited Warranty.

2. DESCRIPTION

A. 2PGM MODE OVERVIEW

The system preferred by operators working in sports production all over America. With continuous record and independent control of both playback channels, you'll never miss a thing!

Figure1A

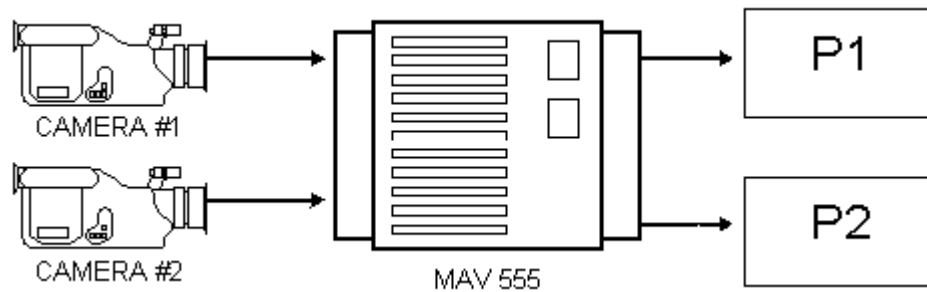

B. PROGRAM & PREVIEW MODE OVERVIEW

The two MAV output channels gives two views into the recorded material, a PREVIEW view and a PROGRAM view. The PROGRAM output is the AIR feed. Only the **[PLAY]** and T-Bar SLOMO functions control this output; all other transport functions control the PREVIEW output.

The PREVIEW output is used to view marked Cue Points, view clips or playback a camera feed to find the desired video.

To switch video to the PROGRAM channel from the PREVIEW channel, the **[CUT]**, **[MIX]** and **[WIPE]** functions are used. The duration of the MIX and the pattern and duration of the WIPE are definable by pressing **[EDIT EFFECT]**.

Figure1B

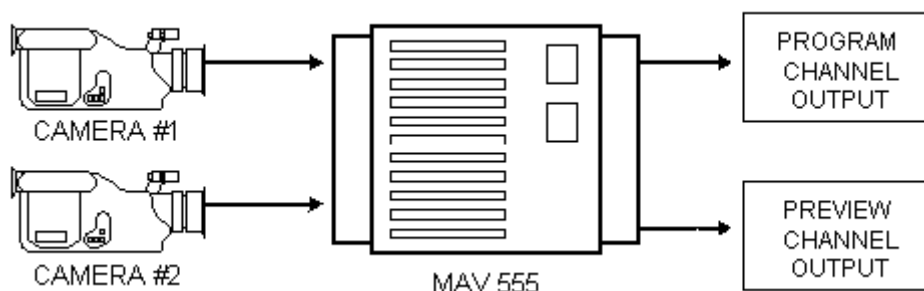

The GANG mode means that all transport functions apply to both Program and Preview channels, e.g., press **[PLAY]** to put both channels in PLAY, move the T-Bar to slomo both channels, press **[STOP]** to stop both channels, press **[REC]** to put both channels into EE mode.

Primary operating modes are:

| | |
|-----------------------|----------------------------|
| PLAYBACK | Press [PLAY] |
| EE Mode | Press [REC] |
| CLIP PLAY Mode | Press [RECALL CLIP] |
| LIST PLAY Mode | Press [CUE LIST] |

FEATURES:

- ✓ 8 Cue Points
- ✓ 400 Clips
- ✓ 12 Play Lists
- ✓ 30 Clips/List
- ✓ 1 or 2 Camera Operation

DEFINITIONS

- Throughout this document, the SONY MAV-555 will be referred to as MAV, MAV-555 or “Video Server”.
- Words surrounded by brackets in bold type, for example, **[ENTER]**, are labeled keys on the ST400.
- Words surrounded by brackets in bold italic type, for example, **[CLIP]**, are multi-function SOFTKEYS
- **[XXX] + [XXX]** means hold the two keys down simultaneously.
- CP mode is CLIP Play; PL mode is LIST Play

3. INSTALLATION

(For 2 in/2 out configuration – both PGM & PVW and 2PGM)

1. Plug one end of a 9-conductor RS422 serial cable into the VTR1 connector on the rear of the DMAT-MAV controller.

Plug the other end of the cable into the connector labeled P1 on the rear panel of the MAV.

2. In a similar manner, connector VTR2 to P2; VTR4 to R1; VTR 5 to R2.

(For 1 PGM configuration for HD MAVs)

1. Connect VTR1 connector on the back of the DMAT to the P2 on the MAV.
2. Connect VTR4 connector on the back of the DMAT to the R2 connector on the MAV.

(For use as a Super Slo-mo unit)

1. Connect VTR1 connector on the back of the DMAT to the P2 on the MAV.
2. Connect VTR4 connector on the back of the DMAT to the R1 connector on the MAV.

(For all configurations)

1. Plug the DB9M connector from the supplied power supply into the power connector on the rear panel of the ST400.
2. Plug the POWER SUPPLY into a wall outlet, 90 VAC TO 240 VAC.
3. Select REMOTE mode on the MAV's front panel.

***DO NOT HOT PLUG! Always connect the power supply to the ST400
BEFORE
connecting to AC power***

Super Slo-mo Connection Diagram

Figure 2A

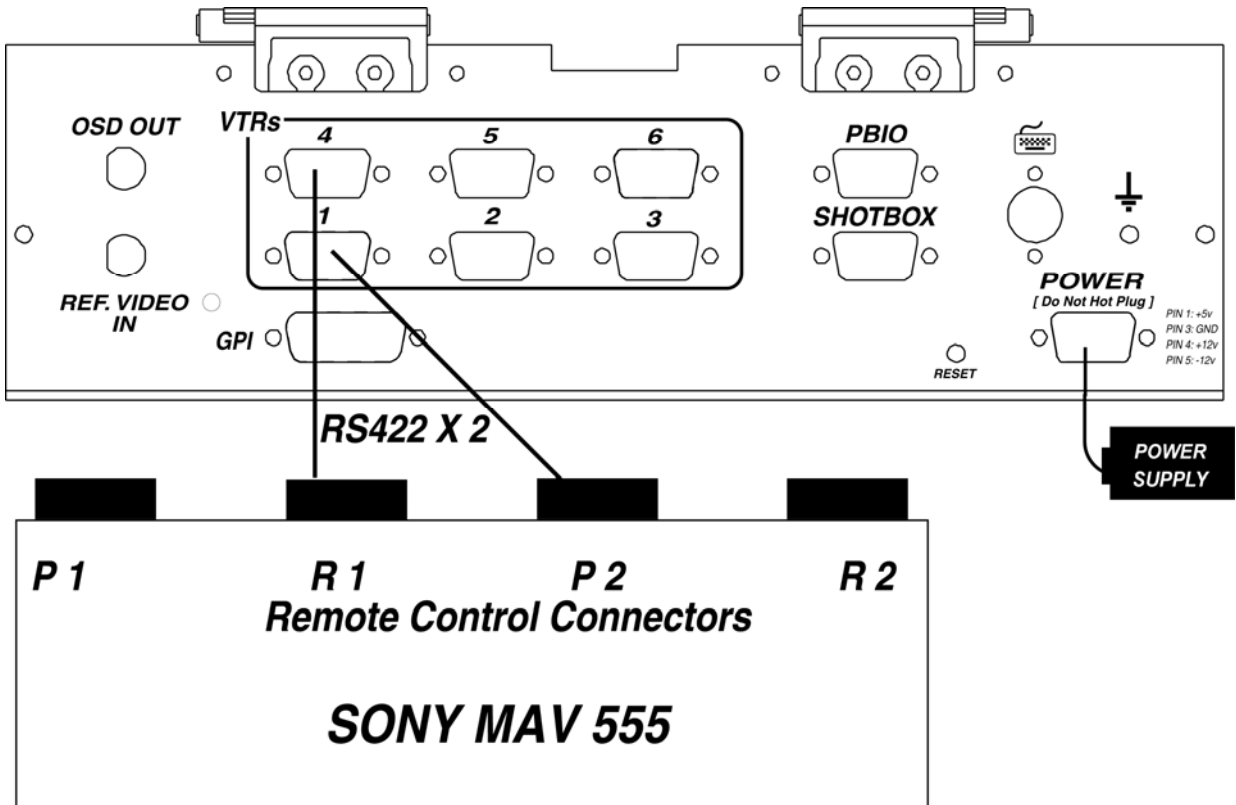

1 PROGRAM Connection Diagram

Figure 2B

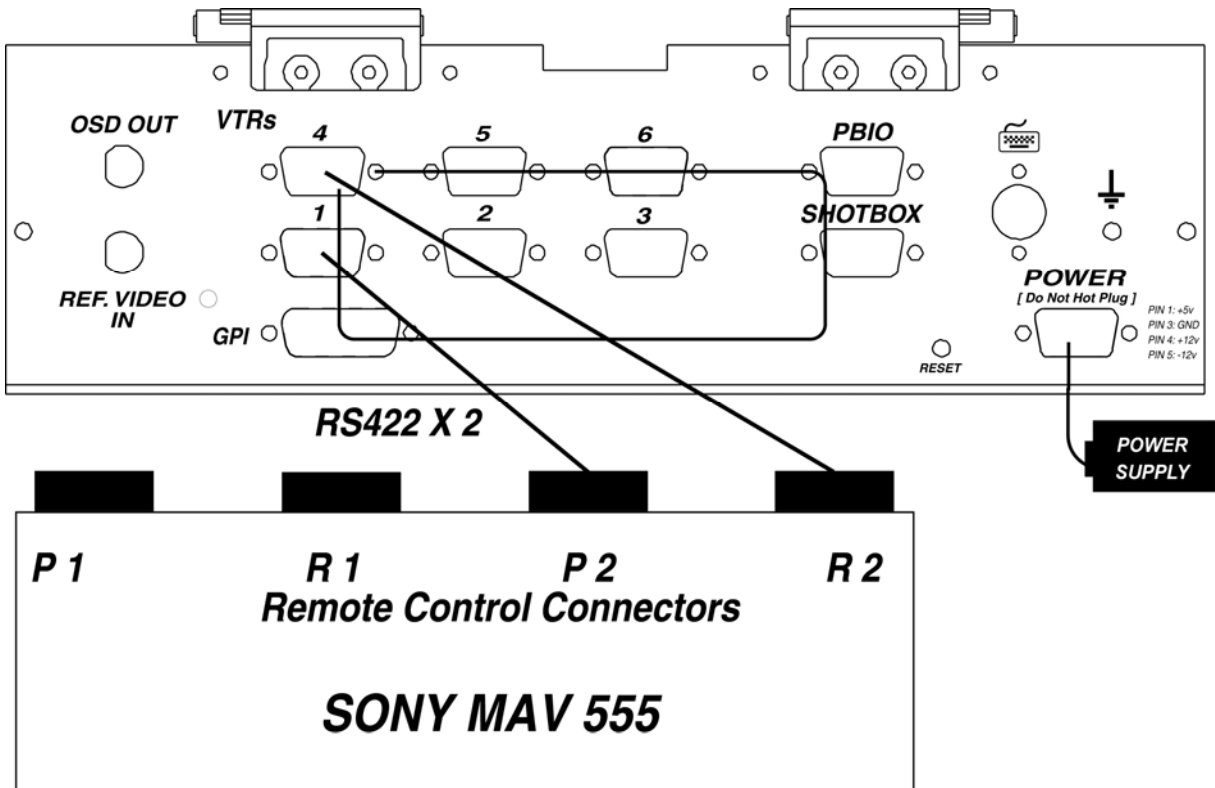

2 PGM and PGM & PVW Connection Diagram

Figure 2C

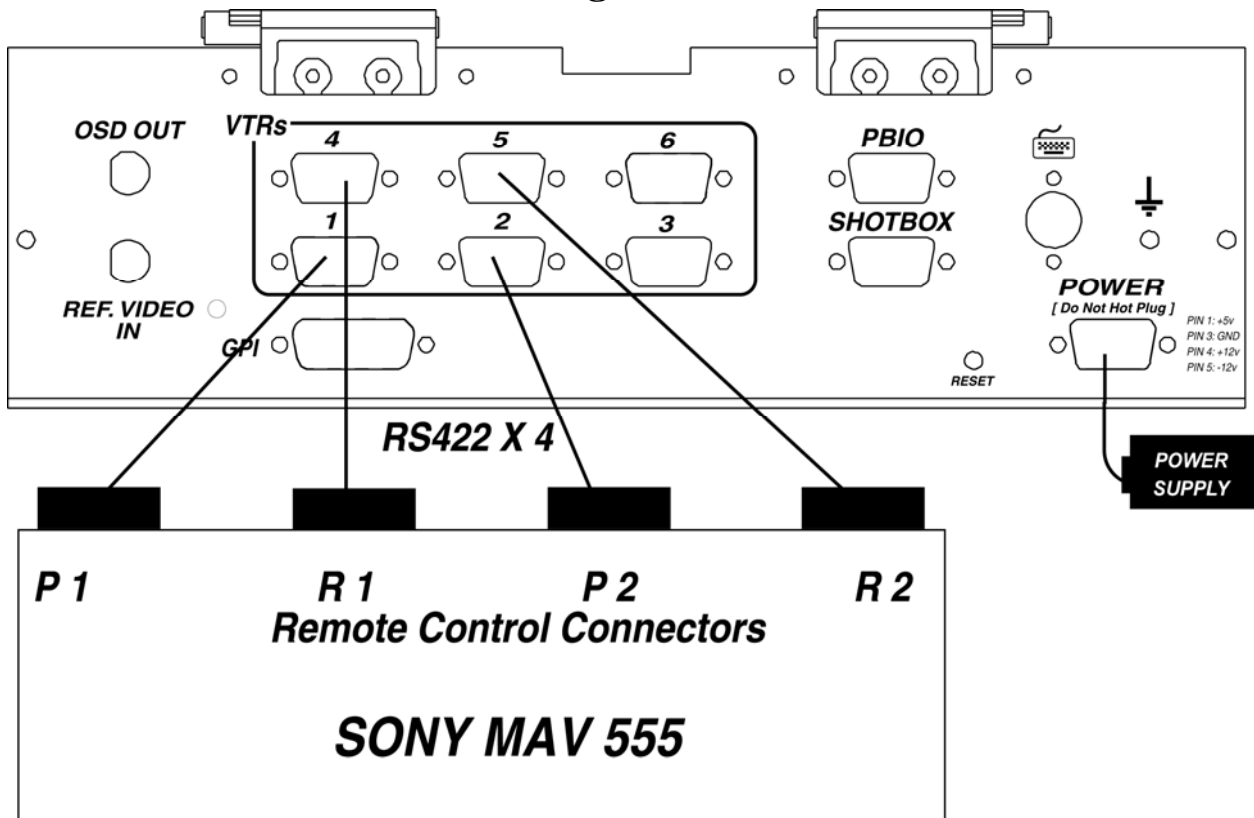

4. GETTING STARTED...

START RECORDING

1. Press **[MENU]**.
2. Press **[RECORD SETUP]**.
3. Press **[NEW R1 CLIP]** or **[NEW R2 CLIP]**.
4. The display prompts: "ENTER ID: num cap".
5. Enter the CLIP ID using the numeric keypad on the ST400 or a PC keyboard (user supplied).
6. Press **[ENTER]**.
7. The display shows the current Record Loop Length.

Press **[ENTER]** to create a clip with this length or enter a new record length using the numeric keypad.
8. Press **[ENTER]** to create the Clip.

The same clip is automatically loaded on the corresponding Play channel.
P 1 on R 1.
P 2 on R 2.
9. Press **[START RECORD]**.

MARK A CUE POINT

Press **[MARK]** to mark the Recorder's time into the Cue Point.

SEARCH TO CUE POINT

1. Press **[NEXT]** or **[LAST]** to search to the NEXT/LAST Cue Point
OR
2. Enter the Cue Point (#0-7) on the numeric keypad; press **[RECALL CLIP]**.
OR
3. Press **[SHIFT] + [NEXT]** or **[SHIFT] + [LAST]** to search to the current Cue Point.

PREROLL

1. Press **[ALT] + [LAST]** to search to the current time minus the preroll time assigned in the MENU.
2. Press **[ALT] + [NEXT]** to search to the current time minus the preroll time X2 assigned in the MENU.

SET AN IN POINT

1. Press **[IN]** to set the IN Point.
The IN indicator on the ST400 will turn on.
The display will show "IN xx:xx:xx:xx ",
where xx:xx:xx:xx is the saved time.
OR
2. Enter the time on the numeric keypad and press **[GOTO]**.
3. Press **[IN]** to save the entered time.

SET AN OUT POINT

1. Press **[OUT]** to set the OUT Point.
The OUT indicator on the ST400 will turn on.
The display will show "OUT xx:xx:xx:xx ",
where xx:xx:xx:xx is the saved time.
OR
2. Enter the time using the numeric keypad and press **[GOTO]**.
3. Press **[OUT]** to save the entered time.
(If AUTOSAVE is on, clip will be saved automatically when the OUT is set.)

CLEAR THE IN POINT

1. Press and hold **[DEL]**, then press and release **[IN]**. The IN indicator will turn off.

CLEAR THE OUT POINT

1. Press and hold **[DEL]**, then press and release **[OUT]**. The OUT indicator will turn off.

SAVE THE CLIP

Press **[SAVE CLIP]**.

RECALL AND PLAY THE CLIP

1. Press **[RECALL CLIP]** to enter CP (Clip Play) mode.
OR
Enter the clip number (#0-399) on the numeric keypad, then Press **[RECALL CLIP]**.
2. Press **[PLAY]**.

ADD CLIP TO PLAYLIST

Press **[ADD ELEM]** to add the currently loaded clip to the current playlist.

PLAYOUT PLAYLIST

Press **[CUE LIST]**, then press **[PLAY]** or move the T-Bar.

PROGRAM AND PREVIEW CHANNELS (PGM & PVW CONFIGURATION ONLY)

The PROGRAM output is the AIR feed. Only the **[PLAY]** and T-Bar SLOMO functions control this output; all other transport functions control the PREVIEW output.

To switch video to the PROGRAM channel from the PREVIEW channel, press **[CUT]**, **[MIX]** or **[WIPE]**.

5. SETUP MENU

1. Press [MENU].
The MENU indicator will turn on.
The Display shown in Figure 3 appears.
2. Use the Softkeys to change the desired mode for the desired option.
OR
Turn the Wheel to select the setup option to be changed.
3. Press [ESC] at anytime to exit **SETUP MENU**.
The MENU indicator will turn off.
4. The currently loaded clips:
The same clip should be loaded on P1 & R1 and on P2 & R2 (for instant replays).
5. If Recorder channels are in record, the letter "R" is displayed.

Figure 3

| | | | |
|------------------------|--|---------------|----------------------------|
| Currently loaded clips | | Model | |
| P1 | 111 | DMAT MAV-555 | |
| R1 | R111 | | |
| | | Software Ver: | |
| P2 | 222 | V4.0 040501 | |
| R2 | R222 | | |
| SEE SETUP 1 → | CLIP HANDLE SIZE=02 SECONDS | | |
| SEE SETUP 2 → | PREROLL = 00:00:05:00 | | |
| SEE SETUP 3 → | WIND SPEED & MODE = +04, HOLD | | |
| SEE SETUP 4 → | FAST JOG SPEED = 03X PLAY SPEED | | |
| SEE SETUP 5 → | STANDARD - NTSC | | |
| SEE SETUP 6 → | TIME MODE - LTC | | |
| | AUTOSAVE - ON | | |
| | CLIP OUT POINT - FREEZE | | |
| | PLAYLIST OUT POINT - FREEZE | | |
| | MAV CONFIGURATION - 2 PROGRAM WITH EFX | | |
| | | | |
| RECORD SETUP | SET & CLEAR | | CHANGE EXIT MENU |

The 6 boxes at the bottom of the display show the function for the corresponding Softkeys below them. These will change depending on what MENU is selected.

On the next few pages are the screens and options that appear when one of the standard selections is highlighted and what the Softkey display will look like.

5A. Record Setup

1. Press [MENU].
2. Press [RECORD SETUP].

Figure 4

| | | | |
|---|----------------|-----------------|----------------|
| Currently loaded clips | | Model | |
| P1 | 111 | DMAT MAV-555 | |
| R1 | R111 | | |
| | | Software Ver: | |
| P2 | 222 | V4.0 040501 | |
| R2 | R222 | | |
| CLIP HANDLE SIZE=02 SECONDS PREROLL = 00:00:05:00 WIND SPEED & MODE = +04, HOLD FAST JOG SPEED = 03X PLAY SPEED STANDARD - NTSC TIME MODE - LTC AUTOSAVE - ON CLIP OUT POINT - FREEZE PLAYLIST OUT POINT - FREEZE MAV CONFIGURATION - 2 PROGRAM WITH EFX | | | |
| Use the softkeys to create RECORD clips and start and stop RECORD on R1 and R2 | | | |
| NEW R1 CLIP | NEW R2 CLIP | START RECORD | STOP RECORD |
| | | | MAIN MENU |

3. Press [NEW R1 CLIP] or [NEW R2 CLIP].
4. The display prompts: "ENTER ID: num cap".
5. Enter a CLIP ID using a PC keyboard (user supplied) or numeric keypad on the ST400.
6. Press [ENTER].
7. The display shows the current Record Loop Length.
Press [ENTER] to accept clip length or enter a new length using the numeric keypad.
8. Press [ENTER] to create the Clip.
The same clip is automatically loaded on the corresponding Play channel: P 1 on R 1, P 2 on R 2.
9. Press [START RECORD].

AUTOSAVE

ON – The clip is saved immediately into the next empty location if both IN & OUT points are set.

OFF – Press [SAVE CLIP] to save the clip

CLIP OUT POINT

FREEZE – Video freezes at the end of clip

OPEN – Video plays through the clip handle

PLAYLIST OUT POINT

FREEZE – Video freezes at the end of clip

OPEN – Video plays through the clip handle

5B. SET & CLEAR

Figure 6

| | | | |
|--|-----------------|----------------|----------------|
| Currently loaded clips | | Model | |
| P1 | 111 | DMAT MAV-555 | |
| R1 | R111 | | |
| P2 | 222 | Software Ver: | |
| R2 | R222 | V4.0 040501 | |
| <p>CLIP HANDLE SIZE=02 SECONDS PREROLL = 00:00:05:00 WIND SPEED & MODE = +04, HOLD FAST JOG SPEED = 03X PLAY SPEED STANDARD - NTSC TIME MODE - LTC AUTOSAVE - ON CLIP OUT POINT - FREEZE PLAYLIST OUT POINT - FREEZE</p> <p>MAV CONFIGURATION - 2 PROGRAM WITH EFX</p> | | | |
| <p>Make your selection using softkeys</p> | | | |
| SET DEFLT | CLEAR MEMORY | CLEAR CLIPS | RESET CLIPS |
| | | | MAIN MENU |

[**SET DEFLT**] Set to Factory Defaults.

[**CLEAR MEMORY**] Clears all memory of the DMAT.

[**CLEAR CLIPS**] Clears all unprotected Clips and all Playlists on the DMAT & MAV. There is also an option to save the Playlists – the clips in those Playlists will only exist there. There can be no modifications made to either those clips or those Playlists.

[**RESET CLIPS**] If for some reason a clip, other than the one that's being recorded, is loaded on the PlayBack channel, use this key to reset the clip back to the proper Clip.

[**MAIN MENU**] Return to main menu.

SETUP-1

CLIP HANDLE

Figure 7

| | |
|---|---|
| Currently loaded clips P1 111 R1 R111 P2 222 R2 R222 | Model DMAT MAV-555 Software Ver: V4.0 040501 |
| CLIP HANDLE SIZE=02 SECONDS PREROLL = 00:00:05:00 WIND SPEED & MODE = +04, HOLD FAST JOG SPEED = 03X PLAY SPEED STANDARD - NTSC TIME MODE - LTC AUTOSAVE - ON CLIP OUT POINT - FREEZE PLAYLIST OUT POINT - FREEZE MAV CONFIGURATION - 2 PROGRAM WITH EFX | |
| CLIP HANDLE SIZE = 05 SECONDS Enter up to 30 sec. using numeric keypad | |
| OK | CANCEL |

Clip Handle-the size of the pad around the saved clip (used for editing clips). 5 seconds means there will be 5 seconds before the IN point and 5 seconds after the OUT point.

It is possible to view the footage beyond the Clip Handles; a new IN or OUT point can then be set.

Enter up to 30 seconds using the numeric keypad.

Press [**OK**] to save this Clip Handle or [**CANCEL**] to return to main menu without changing.

SETUP-2

PREROLL

Figure 8

| | | | |
|--|------|---------------|--------|
| Currently loaded clips | | Model | |
| P1 | 111 | DMAT MAV-555 | |
| R1 | R111 | | |
| | | Software Ver: | |
| P2 | 222 | V4.0 040501 | |
| R2 | R222 | | |
| CLIP HANDLE SIZE=02 SECONDS | | | |
| PREROLL = 00:00:05:00 | | | |
| WIND SPEED & MODE = +04, HOLD | | | |
| FAST JOG SPEED = 03X PLAY SPEED | | | |
| STANDARD - NTSC | | | |
| TIME MODE - LTC | | | |
| AUTOSAVE - ON | | | |
| CLIP OUT POINT - FREEZE | | | |
| PLAYLIST OUT POINT - FREEZE | | | |
| | | | |
| MAV CONFIGURATION - 2 PROGRAM WITH EFX | | | |
| | | | |
| PREROLL = 00:00:05:00 | | | |
| Enter desired preroll using numeric keypad | | | |
| | OK | | CANCEL |

Enter any time to assign a preroll amount using the numeric keypad.

Press **[OK]** to save this preroll or **[CANCEL]** to return to main menu without changing.

SETUP-3

WIND SPEED & MODE

Figure 9

| | | | |
|--|-------|-----------------|--------------|
| Currently loaded clips | | Model | |
| P1 | 111 | DMAT MAV-555 | |
| R1 | R111 | Software Ver: | |
| P2 | 222 | V4.0 040501 | |
| R2 | R222 | | |
| <p>CLIP HANDLE SIZE=02 SECONDS PREROLL = 00:00:05:00 WIND SPEED & MODE = +04, HOLD FAST JOG SPEED = 03X PLAY SPEED STANDARD - NTSC TIME MODE - LTC AUTOSAVE - ON CLIP OUT POINT - FREEZE PLAYLIST OUT POINT - FREEZE</p> <p>MAV CONFIGURATION - 2 PROGRAM WITH EFX</p> | | | |
| <p>WIND MODE - HOLD WIND SPEED = +04</p> | | | |
| HOLD | LATCH | CHANGE SPEED | MAIN MENU |

[HOLD] Press Softkey to select:
HOLD (Fast wind is maintained only while key is depressed.)

[LATCH] Press Softkey to select:
LATCH (Fast wind is initiated and maintained with momentary key press.)

[CHANGE SPEED] Select fast wind speed (4x to 32x play speed).

[MAIN MENU] Return to MAIN MENU Screen.

SETUP-4

FAST JOG SPEED

Figure 10

| | | | |
|--|------|---------------|--------|
| Currently loaded clips | | Model | |
| P1 | 111 | DMAT MAV-555 | |
| R1 | R111 | | |
| P2 | | Software Ver: | |
| R2 | R222 | V4.0 040501 | |
| CLIP HANDLE SIZE=02 SECONDS | | | |
| PREROLL = 00:00:05:00 | | | |
| WIND SPEED & MODE = +04, HOLD | | | |
| FAST JOG SPEED = 03X PLAY SPEED | | | |
| STANDARD - NTSC | | | |
| TIME MODE - LTC | | | |
| AUTOSAVE - ON | | | |
| CLIP OUT POINT - FREEZE | | | |
| PLAYLIST OUT POINT - FREEZE | | | |
| MAV CONFIGURATION - 2 PROGRAM WITH EFX | | | |
| FAST JOG SPEED = 03x | | | |
| Enter from 02x to 20x using numeric keypad | | | |
| | OK | | CANCEL |

Enter a number between 2 and 20 to assign the fast jog speed amount using the numeric keypad.

Press [**OK**] to save this speed or [**CANCEL**] to return to main menu without changing.

SETUP-5

STANDARD

Figure 11

| | | | |
|---|------|---------------|-----------|
| Currently loaded clips | | Model | |
| P1 | 111 | DMAT MAV-555 | |
| R1 | R111 | Software Ver: | |
| P2 | 222 | V4.0 040501 | |
| R2 | R222 | | |
| CLIP HANDLE SIZE=02 SECONDS PREROLL = 00:00:05:00 WIND SPEED & MODE = +04, HOLD FAST JOG SPEED = 03X PLAY SPEED STANDARD - NTSC TIME MODE - LTC AUTOSAVE - ON CLIP OUT POINT - FREEZE PLAYLIST OUT POINT - FREEZE MAV CONFIGURATION - 2 PROGRAM WITH EFX | | | |
| STANDARD - NTSC | | | |
| | NTSC | PAL | MAIN MENU |

[*NTSC*] Select for NTSC Video Standard.

[*PAL*] Select for PAL Video Standard.

[*MAIN MENU*] Return to MAIN MENU Screen.

SETUP-6

TIME MODE

Figure 12

| | | | | | |
|--|------|---------------|--|----|-----------|
| Currently loaded clips | | Model | | | |
| P1 | 111 | DMAT MAV-555 | | | |
| R1 | R111 | Software Ver: | | | |
| P2 | 222 | V4.0 040501 | | | |
| R2 | R222 | | | | |
| CLIP HANDLE SIZE=02 SECONDS | | | | | |
| PREROLL = 00:00:05:00 | | | | | |
| WIND SPEED & MODE = +04, HOLD | | | | | |
| FAST JOG SPEED = 03X PLAY SPEED | | | | | |
| STANDARD - NTSC | | | | | |
| TIME MODE - LTC | | | | | |
| AUTOSAVE - ON | | | | | |
| CLIP OUT POINT - FREEZE | | | | | |
| PLAYLIST OUT POINT - FREEZE | | | | | |
| MAV CONFIGURATION - 2 PROGRAM WITH EFX | | | | | |
| TIME MODE = LTC | | | | | |
| LTC | | VITC | | TM | MAIN MENU |

| | |
|-------------|------------------------------|
| [LTC] | Longitudinal Time Code. |
| [VITC] | Vertical Interval Time Code. |
| [TM] | MAV555 internal Timer Data. |
| [MAIN MENU] | Return to Main MENU Screen. |

MAV CONFIG

Figure 13

| | | | | | | |
|--|----------------|--------------|-------|---------------|-------|--------------|
| Currently loaded clips | | | | Model | | |
| P1 | 111 | | | DMAT MAV-555 | | |
| R1 | R111 | | | Software Ver: | | |
| P2 | 222 | | | V4.0 040501 | | |
| R2 | R222 | | | | | |
| <p>CLIP HANDLE SIZE=02 SECONDS PREROLL = 00:00:05:00 WIND SPEED & MODE = +04, HOLD FAST JOG SPEED = 03X PLAY SPEED STANDARD - NTSC TIME MODE - LTC AUTOSAVE - ON CLIP OUT POINT - FREEZE PLAYLIST OUT POINT - FREEZE</p> <p>MAV CONFIGURATION - 2 PROGRAM WITH EFX</p> | | | | | | |
| Make your selection using softkeys | | | | | | |
| 2PGM W/ EFX | 2PGM NO EFX | PGM & PVW | 1 PGM | SUPER | SLOMO | MAIN MENU |

[2PGM W/ EFX]

2 record and 2 playback with individual control of each channel.

[2PGM NO EFX]

2 record and 2 playback with individual control of each channel (no efx board on MAV).

[PGM & PVW]

2 record and 2 playback with effects – to allow transitions between two channels.

[1 PGM]

Record and playback on 1 channel – for use with HD MAVs.

[SUPER SLOMO]

(See next page)

[MAIN MENU]

Back to MAIN MENU screen.

SUPER SLO-MO

Figure 14

| | | | | | |
|----------------------|-------------|-------------|--|------------------|-------------|
| PGM 1 PB 00:00:02:11 | | | | | |
| R1 00:21:20:05 | | | | CUE = 0 | |
| Speed = +0.00 | | | | 0 | 00:00:00:00 |
| CLIP = 001 | | | | 1 | 00:00:00:00 |
| IN: | 00:00:02:00 | | | 2 | 00:00:00:00 |
| OUT: | 00:00:04:00 | | | 3 | 00:00:00:00 |
| DUR: | 00:00:02:00 | | | 4 | 00:00:00:00 |
| 000 | | 00:04:59:22 | | 5 | 00:00:00:00 |
| 001 | | 00:04:59:22 | | 6 | 00:00:00:00 |
| 002 | | 00:04:59:22 | | 7 | 00:00:00:00 |
| 003 | | 00:04:59:22 | | LIST = 00 | |
| 004 | | 00:04:59:22 | | LD | 00:00:40:00 |
| 005 | | 00:04:59:22 | | CD | 00:00:02:00 |
| 006 | | 00:04:59:22 | | #01 out of 05 | |
| 007 | | 00:04:59:22 | | 1001T | |
| 008 | | 00:04:59:22 | | 1115 | |
| > > 00:00:00:00 | | | | 1002T | |
| | | | | 1004 | |
| | MELT | | | 1/3 x | |
| | CLIP | | | PLAY | |

[*MELT CLIP*]

Creates and loads melt clip

[*1/3 x PLAY*]

Plays back melt clips at 1/3 speed

CREATING and PLAYING OUT MELT CLIP

1. Select a file to put into the MELT by recalling it or by entering its number on the numeric keypad.
2. Press [ADD ELEMENT] to add the element to the playlist.
3. Repeat steps 1 and 2 until all the clips to be melted are added to the list

NOTE: A playlist can only hold 20 clips. To add more clips to MELT, simply go to the next playlist and keep adding elements.

4. Press [*MELT CLIP*]. The display will show “Creating MELT clip” message.

The Melt Clip is loaded. Press [PLAY] to play it out at normal speed or [*1/3 x PLAY*] to play it out at 1/3 speed.

NOTE: The Melt Clip feature is also available in the IIN/IOOUT configuration.

(SUPER SLOMO and IIN/IOOUT have only one output channel. Therefore, transitions are not available.)

6. OPERATIONS

REVERSE SLO-MO WITH T-BAR

1. Press SLOMO key or move the T-Bar to start variplay. The display shows SPEED= x.xx where x.xx is the variable speed of the playback.
2. Press and hold [REV] key. The motion starts with the displayed speed in the reverse direction.
3. Release the key to change the direction to forward.

CREATING CLIPS “ON THE FLY”

1. Press [ALT] + [IN] to mark the IN point using the recorder’s time. The time shows up in the place for the IN point with the whole area highlighted.
2. Press [ALT]+[OUT] to mark the OUT point using the recorder’s time. The time shows up in the place for the OUT point with the whole area highlighted.
3. Press [ALT]+[SAVE CLIP] to save marked IN to OUT as a clip. The highlighted area is cleared upon saving the clip.
4. If the IN and OUT points are not to be saved, press [ESC] to clear IN and OUT points and the highlighted area.

PROTECTING CLIPS

1. Recall the clip to be protected.
2. Press [SHIFT] + [SAVE CLIP]. The letter ‘p’ shows up next to the clip number. That means that this clip cannot be deleted from the MAV and the DMAT until it is unprotected.
3. To unprotect the clip, press [SHIFT] + [SAVE CLIP] again. The letter ‘p’ goes away. The clip can now be deleted.

DELETING CLIPS ONE BY ONE

1. Recall the clip to be deleted.
2. Press [DEL] + [SAVE CLIP].
([OK/CANCEL]) Press the appropriate Softkey.
3. Upon pressing Softkey [OK], the clip will be deleted from the MAV and from the DMAT. The clip will be unloaded, there will be black on the video monitor and the DMAT display will show “No Clip Loaded”.

NOTE: The protected file cannot be deleted until unprotected.
The file that is currently a part of a playlist cannot be deleted until deleted from the playlist.

6A. Creating a Playlist

The two MAV output channels gives two views into the recorded material, a PREVIEW view and a PROGRAM view. The PROGRAM output is the AIR feed. Only the [PLAY] and T-Bar SLOMO functions control this output; all other transport functions control the PREVIEW output.

The PREVIEW output is used to view marked Cue Points, view clips or playback a camera feed to find the desired video.

To switch video to the PROGRAM channel from the PREVIEW channel, the [CUT], [MIX] and [WIPE] functions are used. The duration of the MIX and the pattern and duration of the WIPE are definable by pressing [EDIT EFFECT].

Figure 15

| | | | |
|------------------------------|--|-----------------------------|----------------|
| PGM 1 PB 00:00:02:11 | | PVW 2 PB 00:00:02:11 | |
| R1 00:21:20:05 | | CUE = 0 | |
| R2 00:21:20:05 | | 00 00:00:00:00 | |
| Speed = +0.00 | | 01 00:00:00:00 | |
| CLIP = 001 | | 02 00:00:00:00 | |
| IN: 00:00:02:00 | | 03 00:00:00:00 | |
| OUT: 00:00:04:00 | | 04 00:00:00:00 | |
| DUR: 00:00:02:00 | | 05 00:00:00:00 | |
| 000 00:04:59:22 | | 06 00:00:00:00 | |
| 001 00:04:59:22 | | 07 00:00:00:00 | |
| 002 00:04:59:22 | | LIST = 00 | |
| 003 00:04:59:22 | | LD 00:00:40:00 | |
| 004 00:04:59:22 | | CD 00:00:02:00 | |
| 005 00:04:59:22 | | 01/04 SPD= ---- | |
| 006 00:04:59:22 | | 1001T | |
| 007 00:04:59:22 | | 1115 | |
| 008 00:04:59:22 | | 1002T | |
| > > 00:00:00:00 | | 1004 | |
| SKIP | | SPEED SELECT | EDIT EFFECT |

1. Press [GOTO LIST]. Enter list # (0-11) on the numeric keypad.
OR
Press [GOTO LIST] to make that list the current Playlist.
OR
Press [SHIFT] + [GOTO LIST] to GOTO the NEXT List.
2. [ADD ELEMNT] Appends the currently selected/ user entered Clip # to the end of the current Playlist.
OR
[DELETE ELEMNT] Deletes the currently selected Element (the element of the playlist that is highlighted).
OR
Press [SHIFT] + [DELETE ELEMNT] to delete the current Playlist (not while in PL mode).

3. **[INSERT ELEMNT]** Insert the current/entered Clip # **BEFORE** the highlighted element.
4. **[CUE LIST]** Cues up the list to the first element. Goes to PL (Playlist) mode. The time next to it is the countdown time for the whole playlist.
5. **[SHIFT] + [CUE LIST]** Cues the list in Loop mode.
6. **[SPEED SELECT]** To specify the Slomo Speed of every Playlist element. Press **[SPEED SELECT]**, then move the T-Bar to set speed. Press **[NEXT]** to assign the speed and move to the next element in the list; press **[ENTER]** to assign the speed and exit Speed Select mode; or press **[ESC]** to exit Speed Select mode.

CRT is the Clip's Running Time: Countdown time for the single element.

List = XX, where XX is the playlist Number, 0-11 (12 Lists Total).

LD is the list duration.

CD is the current clip's duration.

The current element is highlighted.

In PL mode, both playback channels are used to show video of the Playlist.

P1 will always be AIR channel.

P2 is the PREVIEW channel. (ONLY when **[PLAY]** is pressed.)

To Exit PL Mode:

1. Press **[REC]** to switch to EE mode.
2. Press **[RECALL CLIP]** to recall individual clips and go to CP mode.

Switching to Recorder is not allowed in PL mode.

All transport functions are available in PL Mode.

NOTE: IF Clips or Playlists are deleted on the MAV, they will not be available for payout from the DMAT-MAV, ***EVEN IF*** the Clip name or Play Lists appear there.

6B. Effects - Press [*EDIT EFFECTS*] to get to this screen
 (Not available in Super Slo-mo configuration)

Figure 16

| | | | | | |
|----------------------|--------------|---------------|-------|-------------|-------------|
| Element #02 | | | | | |
| Transition type: | | 1080 | | | |
| Video transition: | | 30 frames | | | |
| Audio transition: | | 30 frames | | | |
| Default WIPE type: | | 0001 | | | |
| Default WIPE length: | | 15 frames | | | |
| Default MIX length: | | 15 frames | | | |
| CUT | DEFLT MIX | DEFLT WIPE | CLEAR | AV SPLIT | AS- SIGN |

Upper line is the number of the element in the Playlist after which the transition will happen.

The Transition Type is the current effect number. Effect duration is the length of the effect. To change the length, enter up to 99 frames on the numeric keypad. Press [**ENTER**].

Press [**ASSIGN**] to assign the displayed transition to the Playlist element.

Press [**ESC**] to exit without changing the transition. Default transition is a CUT.

Press [**CLEAR**] to clear the current transition.

Press [**DEFAULT WIPE**] or [**DEFAULT MIX**] to assign the defaults to the playlist.

Press [**ALT**] + [**DEFAULT WIPE**] or [**ALT**] + [**DEFAULT MIX**] to change the default.

Press [**AV SPLIT**] Enter separate transition rates for video and audio. Press [**AV SPLIT**] again to turn the split off; the indicator will go out and the video and audio durations will be the same.

Press [**LAST**] and [**NEXT**] to walk through the elements in the Playlist.

If the transition is assigned to an element, all the elements that follow and don't have transitions assigned to them will use that transition.

For example:

Element 0 has dissolve transition assigned to it.

Elements 1 & 2 don't have transitions

Element 3 has a wipe assigned to it

Element 4 has a cut assigned to it

Elements 5 & 6 don't have transitions.

When the Playlist plays out, the following will happen:

0 → 1 will dissolve

1 → 2 will dissolve

2 → 3 will dissolve

3 → 4 will wipe

4 → 5 will cut

5 → 6 will cut

When the element has a transition assigned to it, the display shows "T" next to the element name.

If the transition is a cut, the display shows "C".

If there is no transition assigned (default transition), the space next to the Element's name is blank.

7. FUNCTION TABLE

| Function | Key Press | Description |
|-------------------|-------------------------|---|
| PLAY | [PLAY] | Puts the currently loaded clip into Play |
| STOP | [STOP] | Press once to STILL frame VTR. Press again to put VTR into STOP mode. |
| REWIND | [RWD] | Press and HOLD to shuttle. Release key to stop. Set WIND speed in MENU. |
| FFWD | [FFWD] | Press and HOLD to shuttle. Release key to stop. Set WIND speed in MENU. |
| JOG | [JOG] | Select JOG mode and enable the Wheel. |
| SHUTTLE | [SHUTTLE] | Select SHUTTLE mode and enable the Wheel. |
| SLOMO | [SLOMO] | Press SLOMO to slo-mo the VTR. Turn the Wheel or move the T-Bar to change the play speed. Press SLOMO to STILL frame OR press any transport key to exit. |
| MARK IN POINT | [IN] | Marks new IN point of a Clip |
| MARK OUT POINT | [OUT] | Marks new OUT point of a Clip |
| DELETE IN POINT | [DEL] + [IN] | Delete IN point. (Sets the IN point = IN+CLIP Handle Size-see MENU) |
| DELETE OUT POINT | [DEL] + [OUT] | Delete OUT point. (Sets the OUT point = OUT + CLIP Handle Size-see MENU) |
| SAVE CLIP | [SAVE CLIP] | Save IN and OUT as the CURRENT CLIP OR if the Clip # is entered on the numeric keypad (0-399), it saves it as that number. |
| SAVE CLIP | [ALT] + [SAVE CLIP] | Save a clip in any mode. |
| NAME CLIP | [NAME CLIP] | Assign an alphanumeric name to the selected CLIP. Type a name using an attached PC keyboard (user supplied) or numeric keypad on the ST400. Press [ENTER] to assign the name to the Clip. Press [CLEAR] to erase the name of a Clip. |
| RECALL CLIP | [RECALL CLIP] | Loads the currently selected CLIP OR if the clip # is entered on the numeric keypad (0-399), it loads that clip. |
| RECUE CLIP | [SHIFT] + [RECALL CLIP] | Recue the loaded Clip to the beginning. (ONLY available in CP mode). |
| GOTO IN POINT | [SHIFT] + [IN] | GOTO the IN Point. |
| GOTO OUT POINT | [SHIFT] + [OUT] | GOTO the OUT Point. |
| RECALL LAST CLIP | [LAST] | (In CP Mode) Recalls the Last Clip. (In Edit Effect) Move between playlist's elements & view transitions |
| RECALL NEXT CLIP | [NEXT] | (In CP Mode) Recalls the Next Clip. (In Edit Effect) Move between playlist's elements & view transitions |
| MARK CUE POINT | [MARK] | Marks the recorder's time into a cue point and advances to the next cue point. |
| MARK IN POINT | [ALT] + [IN] | Marks IN point in any mode |
| MARK OUT POINT | [ALT] + [OUT] | Marks OUT point in any mode |
| RECORD | [REC] | Returns to EE mode. Unload the clip, loads the same material that is currently being recorded. Time Code and Video come from the Recorder VTR. |
| LAST CUE | [LAST] | IN PB Mode, search to last cue. |
| NEXT CUE | [NEXT] | IN PB Mode, search to next cue. |
| LAST ELEMENT | [LAST] | In PL Mode, search to Last Element |
| NEXT ELEMENT | [NEXT] | In PL Mode, search to Next Element |
| SCROLL | [SCROLL] | Scroll through list of clips |
| GANG AND PLAYBACK | [GANG] | Gangs two playback channels for simultaneous playback. |

8. SPECIFICATIONS

| | | |
|------------------------|---|--|
| Power: | 90 VAC to 265 VAC adapter supplied with IEC connector | |
| Size: | [L" x W" x H"] 12 3/4" x 8" x 1 3/4" (front) 3 5/8" (rear) [8 5/8" high to top of display] | |
| Weight: | 10 lbs. | |
| Rear Panel Connectors: | VTR1, 2, 3, 4, 5,6 GPI Power SHOTBOX PBIO Keyboard Ref. Video In Ground | (All DB9F) (DBF26F) (DB9M) (DB9F) (DB9F) (6 pin mini DIN) (BNC) Threaded stud |
| Display: | Large 40 characters by 30 line Easy to read, back-lit LCD display | |
| Jog/Shuttle Wheel: | With mechanical detents | |
| "T"-bar: | Slo-mo 0-200% of Play Speed | |

RS422 SERIAL CONNECTOR 9 Pin D type, female (DB9F)

| | | | | |
|-------|---|-----------------|---|----------------|
| Pin # | 1 | Frame Ground | 6 | Receive Common |
| | 2 | Receive A ← | 7 | Receive B ← |
| | 3 | Transmit B → | 8 | Transmit A → |
| | 4 | Transmit Common | 9 | Frame Ground |
| | 5 | Spare | | |

POWER CONNECTOR 9 Pin D type, male (DB9M)

| | | | | |
|-------|---|---------|---|--------|
| Pin # | 1 | +5v DC | 6 | +5 VDC |
| | 2 | +5v DC | 7 | Ground |
| | 3 | Ground | 8 | Ground |
| | 4 | +12 VDC | 9 | Ground |
| | 5 | -12 VDC | | |

SHOTBOX RS422 SERIAL CONNECTOR 9 Pin D type, female

| | | | | |
|-------|---|------|---|------|
| Pin # | 1 | None | 6 | None |
| | 2 | None | 7 | None |
| | 3 | None | 8 | None |
| | 4 | None | 9 | None |
| | 5 | None | | |

PBIO RS422 SERIAL CONNECTOR 9 Pin D type, female

| | | | | |
|-------|---|------|---|------|
| Pin # | 1 | None | 6 | None |
| | 2 | None | 7 | None |
| | 3 | None | 8 | None |
| | 4 | None | 9 | None |
| | 5 | None | | |

GPI IN/OUT CONNECTOR 26 Pin D type, female (DB26F)

| Pin # | Function | Pin # | Function |
|--------------|-----------------|--------------|-----------------|
| 1 | No Connection | 14 | No Connection |
| 2 | No Connection | 15 | No Connection |
| 3 | No Connection | 16 | No Connection |
| 4 | No Connection | 17 | No Connection |
| 5 | No Connection | 18 | No Connection |
| 6 | No Connection | 19 | No Connection |
| 7 | No Connection | 20 | No Connection |
| 8 | No Connection | 21 | No Connection |
| 9 | No Connection | 22 | No Connection |
| 10 | No Connection | 23 | No Connection |
| 11 | No Connection | 24 | No Connection |
| 12 | No Connection | 25 | No Connection |
| 13 | No Connection | 26 | No Connection |

9. KEY LAYOUT

ST400 KEY CONFIGURATION

DMAT-MAV-555

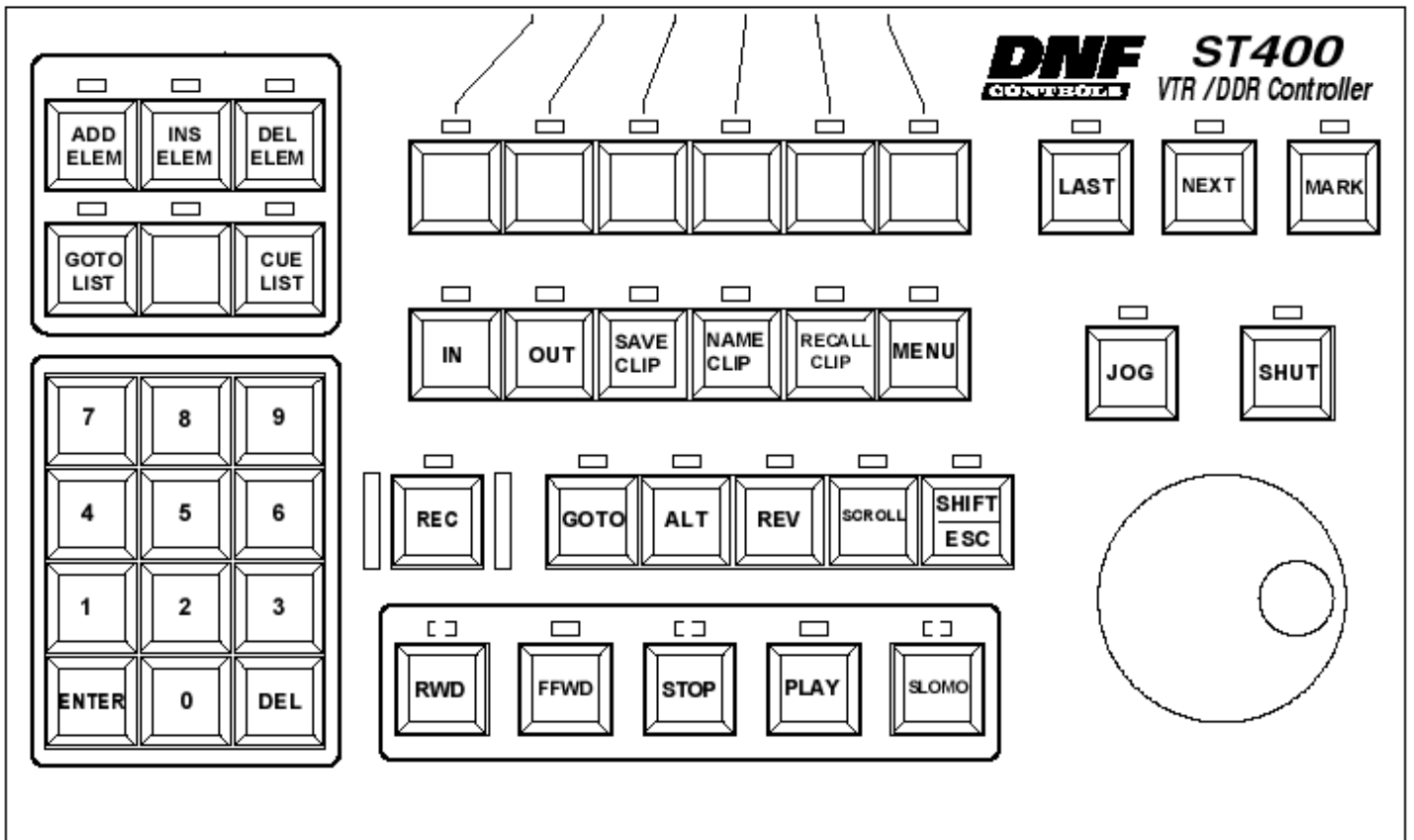

10. DNF CONTROLS LIMITED WARRANTY

DNF Controls warrants its product to be free from defects in material and workmanship for a period of one (1) year from the date of sale to the original purchaser from DNF Controls.

In order to enforce the rights under this warranty, the customer must first contact DNF's Customer Support Department to afford the opportunity of identifying and fixing the problem without sending the unit in for repair. If DNF's Customer Support Department cannot fix the problem, the customer will be issued a Returned Merchandise Authorization number (RMA). The customer will then ship the defective product prepaid to DNF Controls with the RMA number clearly indicated on the customer's shipping document. The merchandise is to be shipped to:

DNF Controls
12843 Foothill Blvd., Suite C
Sylmar, CA 91342
USA

Failure to obtain a proper RMA number prior to returning the product may result in the return not being accepted, or in a charge for the required repair.

DNF Controls, at its option, will repair or replace the defective unit. DNF Controls will return the unit prepaid to the customer. The method of shipment is at the discretion of DNF Controls, principally UPS Ground for shipments within the United States of America. Shipments to international customers will be sent via air. Should a customer require the product to be returned in a more expeditious manner, the return shipment will be billed to their freight account.

This warranty will be considered null and void if accident, misuse, abuse, improper line voltage, fire, water, lightning or other acts of God damaged the product. All repair parts are to be supplied by DNF Controls, either directly or through its authorized dealer network. Similarly, any repair work not performed by either DNF Controls or its authorized dealer may void the warranty.

After the warranty period has expired, DNF Controls offers repair services at prices listed in the DNF Controls Price List. DNF Controls reserves the right to refuse repair of any unit outside the warranty period that is deemed non-repairable.

DNF Controls shall not be liable for direct, indirect, incidental, consequential or other types of damage resulting from the use of the product.

###