



12843 Foothill Blvd. Suite C
Sylmar, California 91342
V: 818.898.3380
F: 818.898.3360
sales@dnfcontrols.com

**Model No. ST304-DSR1K
(& ST304-DSR1K-T)**

for

Sony DSR-DR1000 DDR

**SLOW MOTION CONTROLLER
WITH SEGMENT PLAYOUT**

USER MANUAL

Table of Contents

1. REVISION HISTORY	3
<i>GETTING STARTED . . .</i>	4
2. SYSTEM DESCRIPTION	4
DEFINITIONS	4
3. INSTALLATION	5
A. ST300 INSTALLATION	5
B. DSR-DR1000 SETUP	5
4. OPERATION	7
A. LCD DISPLAY	7
B. TRANSPORT CONTROL	7
C. IN/OUT POINTS	8
D. SELECT A CUE POINT	8
E. SAVE A CUE POINT (AUTO MARK OFF)	8
F. SAVE A CUE POINT (AUTO MARK ON)	9
G. GOTO/PREROLL TO A CUE POINT	9
H. PLAYING SEGMENTS	9
I. GOTO/PREROLL TO A MANUALLY ENTERED TIME	9
J. RECORD MODE SELECTION	10
5. DSR-DR1000 FUNCTIONS	10
A. START RECORD	10
B. STOP RECORD	10
C. GO TO EE	11
D. GOTO LIVE	11
<i>ADVANCED FEATURES . . .</i>	12
6. TRANSFER CUELIST	12
A. TRANSMIT CUE LIST FUNCTION	12
B. RECEIVE CUE LIST FUNCTION	13
<i>REFERENCE . . .</i>	14
7. SETUP MENU	14
8. FUNCTION TABLE	17
9. SPECIFICATIONS	19
RS422 SERIAL CONNECTOR	19
POWER CONNECTOR	19
AUX PORT RS422 SERIAL CONNECTOR	19
GPI IN/OUT CONNECTOR	20
10. KEY LAYOUT	21
11. DNF CONTROLS LIMITED WARRANTY	22

Manual Version:.....1.5 070708
Document ID:.....ST304-DSR1K_User_Manual.doc

1. REVISION HISTORY

071204	1.0	Original document
100604	Rev. 1.1	Reformatted
111804	Rev. 1.2	Added GOTO LIVE Section. Added Video Standard Selection and INPUT Video Delay Entry to the SETUP MENU.
122104	Rev. 1.3	Updated GPI functions.
020305	Rev. 1.4	Updated to reflect current software.
070708	Rev 1.5	Updated with DSR-1000 settings.

Getting Started . . .

2. SYSTEM DESCRIPTION

The ST304-DSR1K Slow Motion Controller combines the power of the ST300 Slow Motion Controller, a larger 4-line display, and with the power of the Sony DSR-DR1000.

The key functions:

- Simultaneous Record and Playback.
- Segment Payout
- Press **[EE]** to go to live video.

DEFINITIONS

- ❑ Throughout this document VTR, DDR, VDR & Video Server will be referred to collectively as “VTR.”
- ❑ The ST304-DSR1K will be referred to as “ST300.”
- ❑ Words surrounded by brackets, for example, **[ENTER]**, are keys on the ST300.
- ❑ Words surrounded by “curly” brackets, for example *{UPDATE}*, are softkeys on the ST300.
- ❑ **[XXX] + [XXX]** means hold the two keys down simultaneously.

3. INSTALLATION

a. ST300 INSTALLATION

- 1) Connect VTR1 connector on the back of the ST300 to the REMOTE OUT (Play) connector on the DSR-DR1000 #1.
- 2) Connect VTR3 connector on the back of the ST300 to the REMOTE IN (Record) connector on DSR-DR1000 #1.
- 3) Connect VTR2 connector on the back of the ST300 to the REMOTE OUT (Play) connector on the DSR-DR1000 #2.
- 4) Connect VTR4 connector on the back of the ST300 to the REMOTE IN (Record) connector on DSR-DR1000 #2.
- 5) Connect the supplied POWER SUPPLY, APX#4108 into the POWER connector on the rear of the ST300. Plug the Power Supply into an outlet, 90 VAC – 240 VAC.
- 6) Select REMOTE mode on the VTR's front panel.
- 7) Check the **SETUP MENU** prior to using the Slow Motion Controller to confirm proper Record mode, SLO-MO speed range, and other User settable modes.

b. DSR-DR1000 SETUP

Refer to the DSR-DR1000 User Manual. Set LINE OUT SELECT button to 'P' to view playback on DSR output.

SET-UP FOR THE DSR1000

1) SET-UP MENU (MENU GRADE = ENHANCED MODE)

a. OPERATIONAL FUNCTION

1- REPEAT FUNCTION = OFF

2- AUTO EE SELECT

A - FWD/RWD = PB

B - STOP = PB

C - STAND BY OFF = EE

3- LOCAL ENABLE = STOP

4- REC MODE = NORMAL REC

5- REC INHIBIT = OFF

6- AFTER CUE-UP = STILL

7- PLAY START = 5 FRAMES

b. INTERFACE SELECT

1- REMOTE I/F = 9 PIN (DUAL)

2) DISK MENU

a. DELETE = ALL DELETE

Connection Diagram

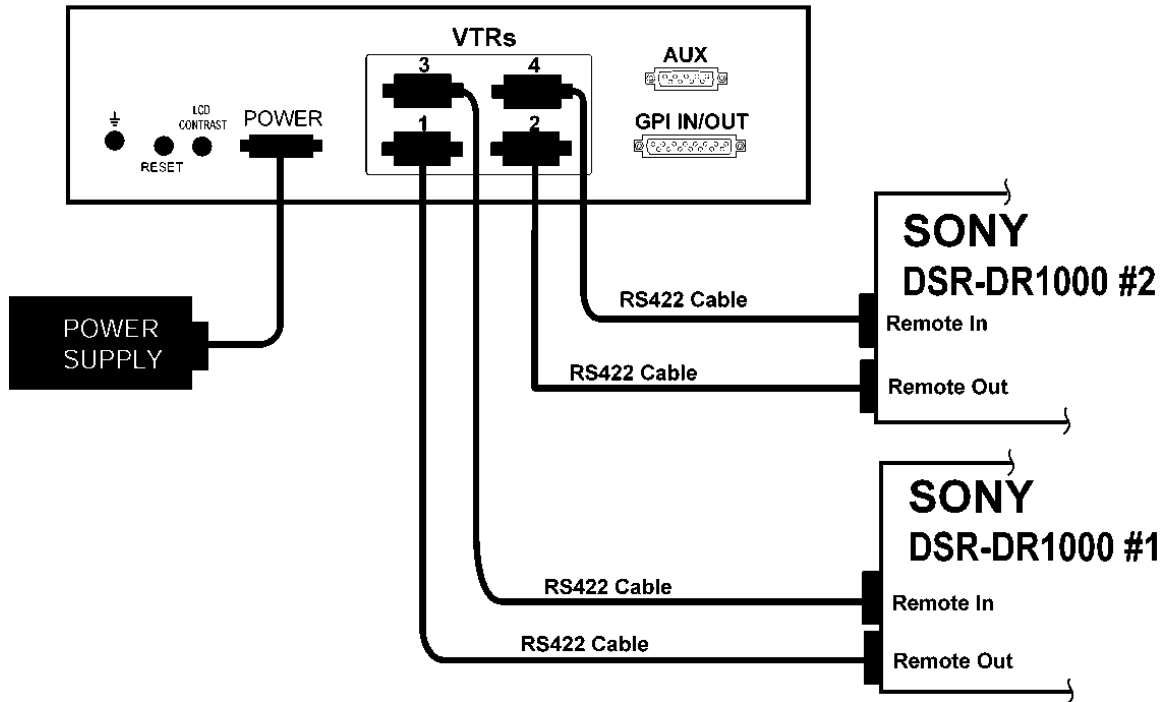

4. OPERATION

a. LCD DISPLAY

During normal operation, the top row of the display shows the current time location of the selected Player. The second line shows the current time of the Recorder and the selected time mode.

For example: P 01:12:09:23
R 01:13:09:23 TC

Time Modes - TM= Tape Timer TC= LTC VT= VITC

The currently selected SLO-MO speed is displayed on the far right side of the top row.

The bottom rows of the display shows the current Cue Point number and its contents or the contents of currently marked IN and OUT points.

When IN & OUT LEDs are ON, the 3rd and 4th lines of the display show the content of current IN & OUT. When IN & OUT LEDs are off and there is an equal sign (“=”) between IN (OUT) and the Timecode, the 3rd and 4th lines of the display show the content of currently selected cuepoint.

b. TRANSPORT CONTROL

Select the desired transport function by pressing the appropriate switch on the ST300.

The Real-Time Status Indicators will light to indicate the VTR's current tape transport mode.

For example: Pressing **[PLAY]** will put the Player into the PLAY mode.
The PLAY status Indicator will turn on when the VTR is in PLAY mode.

OR

Press **[SHIFT] + [RECORD]** to put the Recorder into RECORD mode. (See SETUP MENU.)

The RECORD status indicator will turn on when the VTR is in RECORD Mode.

NOTE: Check SETUP MENU prior to using the SLOW MOTION CONTROLLER to confirm proper Record mode and other User settable modes.

c. **IN/OUT POINTS**

1) **Mark IN/OUT Point**

Press IN (OUT) to mark current time as IN (OUT) point.

Press **[SHIFT] + [IN]** to manually enter the time into the IN point. The IN LED turns on.

Press **[SHIFT] + [OUT]** to manually enter the time into the OUT point. The OUT LED turns on.

2) **Delete IN (OUT) Point**

Press **[DEL] + [IN]** (**[DEL] + [OUT]**).
The current IN (OUT) point is deleted.
IN (OUT) LED turns off.

3) **GOTO IN Point**

Press **[RECUE]** to search to currently selected IN point.

d. **SELECT A CUE POINT**

Press **[NEXT CUE]** or **[LAST CUE]** to step through the Cue Points.
OR

Manually enter the desired Cue Point number using the numeric keypad.

The current Cue Point number and its contents will be shown on the lower half of the display.

e. **SAVE A CUE POINT (AUTO MARK OFF)**

AUTO MARK allows one-key marking of segments by automatically calculating the OUT point. You can turn it ON/OFF in the SETUP MENU.

Press **[IN]** or **[MARK]** to save time into the IN Point of the current Cue Point.
If EE light is ON, Recorder's time will be saved into the IN Point of the Cue Point.
If Advance option is set, time will be saved into the next Cue Point's IN Point.

Press **[OUT]** to save time into the OUT Point of the CURRENT Cue Point.
If EE light is ON, Recorder's time will be saved into the CURRENT OUT Point of the Cue Point.

Note: In order to save an OUT point to the current Cue Point, the current Cue Point must have an IN point saved FIRST

f. SAVE A CUE POINT (AUTO MARK ON)

If AUTO MARK MODE is ON, when [IN] or [MARK] key is pressed, the OUT point is automatically calculated as IN + SEG duration, then saved in the cuepoint.

When OUT key is pressed, the IN is automatically calculated as OUT – SEG duration, and saved in the cuepoint.

AUTO MARK allows one-key marking of segments by automatically calculating the OUT point. You can turn it ON/OFF in the Setup Menu.

g. GOTO/PREROLL TO A CUE POINT

- 1) Select the desired Cue Point. The Cue number and its contents are shown on the bottom line of the display.
- 2) Press [GOTO] to search to the IN point saved in the Cue Point. After cuepoint is recalled, the IN and OUT LEDs are ON.

h. PLAYING SEGMENTS

- 1) Select VTR channel to PLAY.
- 2) Press [PLAY] key.

The Player will start playing and it will stop when the time code reaches the OUT point.

The third line of the display shows “Playing Segment...”

If the Player is positioned after the OUT point, the payout will continue until [STOP] is pressed.

- 3) Press [PLAY] + [SHIFT] to disregard the OUT point and continuously play until [STOP] is pressed.
- 4) In Variplay (SloMo) mode, the Playback will stop once the time code reaches the OUT point.

i. GOTO/PREROLL TO A MANUALLY ENTERED TIME

- 1) Press [ENTER TIME] to use the numeric keypad.
Manually enter a time on the numeric keypad.
- 2) Press [GOTO] OR [RECUE] to search to the entered time.
OR

Press [ESC] to exit without searching.

The ENTER TIME indicator will turn off.

j. RECORD MODE SELECTION

- 1) Press [MENU]. The MENU indicator will turn on.
- 2) Turn the Wheel until “REC” is viewed on the top line of the display. The current Record mode is shown.
- 3) Press [MENU] to select:
Record Lockout, Assemble, Crash or Insert Record mode.
- 4) INSERT ONLY - Press the desired Softkey to toggle Video, Audio1, Audio2, Audio3 or Audio4 record on/off.

The **Softkeys** are located just below the display.
Follow the line graphic from the bottom of the display to the Softkey.

- 5) Press [ESC] to exit the MENU. The MENU indicator will turn off.
OR

Turn the Wheel for other setup options.

5. DSR-DR1000 FUNCTIONS

a. START RECORD

- 1) Press [SHIFT] + [REC] on VTR1 to start recording on Record channel connected to VTR3 connector of the ST300.
- 2) The Record LED turns ON.
- 3) Press [SHIFT] + [REC] on VTR2 to start recording on Record channel VTR4 connector of the ST300 (if second DSR is connected).
- 4) The Record LED turns ON.

b. STOP RECORD

- 1) Press [SHIFT] + [STOP] on VTR1 to stop recording on Record channel connected to VTR3 connector of the ST300.
- 2) The Record LED turns OFF.
- 3) Press [SHIFT] + [STOP] on VTR2 to stop recording on Record channel connected to VTR4 connector of the ST300 (if second DSR is connected).
- 4) The Record LED turns OFF.

c. GO TO EE

Press **[EE]** key to go to Live video on the corresponding Playback Channel. The EE LED turns on.

When EE light is ON, **[MARK]**, **[IN]** and **[OUT]** keys mark the Recorder's time code.

If EE LED is OFF, **[MARK]**, **[IN]** and **[OUT]** keys mark the Player's Time code.

d. GOTO LIVE

- 1) Press **[REC]** key.
- 2) The Player searches to the current Recorder time minus user-defined INPUT Video Delay. (See SETUP MENU.)
- 3) The Player starts playing.

Advanced Features . . .

6. TRANSFER CUELIST

a. TRANSMIT CUE LIST FUNCTION

The TRANSMIT CUE LIST function allows you to transmit your list of Cue Points to a PC, using the provided utility software on the PC, or to another ST300. Transfer to a PC requires OpSuite 3.0 software, which runs on a Windows-based computer. Contact DNF Controls for more information.

1) To Transmit Cue Points to Another ST300

- a) Connect the VTR4 connector on the rear of the ST300 to the VTR4 connector of the receiving ST300 using an RS422 9-pin cable with TX and RX lines crossed. (A “turnaround” cable.)
- b) Press [**MENU**].
- c) Scroll the Wheel until “Transmit CUE list? YES=Enter, Exit=ESC” is displayed.
- d) Press [**ENTER**] to start transmitting. The Display shows “Waiting to transmit” on the first line.
- e) When the Receiver is ready, transfer starts automatically. The Display now shows “Transmitting cue list.”
- f) After the transfer is over, the display shows “Transfer is over” for one second and then shows “Waiting to transmit” again.
- g) Connect another ST300 to transmit the list again.
OR

Press [**ESC**] twice to exit the MENU mode.

2) To Transmit Cue Points to a PC

- a) Connect the VTR4 connector on the back of the ST300 to one of the COM ports on the PC using a RS422 to RS232 adapter.
- b) Repeat steps a) thru g) of “To Transmit Cue Points to Another ST300.”

b. RECEIVE CUE LIST FUNCTION

The RECEIVE CUE LIST function allows you to receive a list of Cue Points from a PC or from another ST300. Transfer to a PC requires OpSuite 3.0 software, which runs on a Windows-based computer. Contact DNF Controls for more information.

1) To Receive Cue Points From Another ST300

- a) Connect the VTR4 connector on the back of the ST300 from the VTR4 connector of the transmitting ST300 using RS422 9-pin cable with TX and RX lines crossed.
(A “Turnaround” Cable)
- b) Press [**MENU**].
- c) Scroll the Wheel until “Receive CUE List? YES=Enter, Exit=ESC” is displayed.
- d) Press [**ENTER**] to start receiving.
The Display shows “Waiting to receive” on the first line.
- e) When the Transmitter is ready, transfer starts automatically. The Display now shows “Receiving cuelist.”
- f) After the transfer is over the display shows “Done-Success! Press any key...”
- g) Press any key. The display shows “Receive cuelist?” message.
- h) Press [**ESC**] to exit the MENU mode.

2) To Receive Cue Points from the PC

- a) Connect the VTR4 connector on the back of the ST300 to one of the COM ports on the PC using RS422 to RS232 adapter.
- b) Repeat steps a) thru h) of “To Receive Cue Points From Another ST300.”

Reference . . .

7. SETUP MENU

- ❑ Press [**MENU**]. The MENU indicator will turn on. Turn the Wheel to select item to change.
- ❑ Use the Softkeys to change the desired mode for that option. Turn the Wheel at anytime to select another item.
- ❑ Press [**ESC**] at anytime to exit **SETUP MENU**. The MENU indicator will turn off.

<u>MENU MODES</u>	<u>(Turning Wheel Clockwise)</u>
RECORD	Press [MENU] to select the desired record mode: Lockout or Crash (Full).
WIND MODE	Press Softkey to select: <i>{HOLD}</i> (Fast wind is maintained only while key is pressed.) OR <i>{LATCH}</i> (Fast wind is initiated and maintained with momentary key press.) Select fast wind speed (3.9 to 23.7) by pressing Softkey below <i>{S PD}</i> .

<p>SLOMO</p>	<p>ST300 display shows (T-Bar version):</p> <table border="1" data-bbox="781 235 1221 350"> <tr> <td>SLOMO with:</td> <td>TBAR</td> </tr> <tr> <td>Wheel</td> <td>SpdRange Preset</td> </tr> </table> <p>ST300 display shows (Non T-Bar version):</p> <table border="1" data-bbox="786 388 1227 504"> <tr> <td>SLOMO with:</td> <td>WHEEL</td> </tr> <tr> <td>SpdRange</td> <td>Preset</td> </tr> </table> <p>Press Softkey [TBAR] (or [WHEEL]) to toggle between T-BAR and WHEEL.</p> <p>The T-BAR has two speed ranges: 0 → +200 with a detent at +100% play speed OR 0 → +100 with a detent at +100%</p> <p>For Wheel only: Press Softkey {<i>SPEED</i>} to select SLOMO speed ranges:</p> <p>Press Softkey to select: 0 → +200 OR -100 → +200. Press Softkey {<i>BACK</i>} to return to SLOMO MENU.</p> <p>Press [ESC] to exit SETUP MENU OR turn the Wheel to select another item.</p> <p>For Wheel only: Press Softkey {<i>PRSET</i>} to select the SLOMO Preset Speed Mode.</p> <p>Press Softkey {<i>UPDATE</i>}.</p> <p>When exiting SLOMO mode, the last used speed is saved in the Preset Speed register.</p> <p>Press Softkey {<i>STATIC</i>}.</p> <p>The Preset Speed register is NOT updated when exiting SLOMO mode. It is only changed by [SHIFT] + [SLOMO] (PRESET SLOMO).</p>	SLOMO with:	TBAR	Wheel	SpdRange Preset	SLOMO with:	WHEEL	SpdRange	Preset
SLOMO with:	TBAR								
Wheel	SpdRange Preset								
SLOMO with:	WHEEL								
SpdRange	Preset								
<p>TBAR AUTOENABLE</p>	<p>Press Softkey [ON] to enable slomo to be engaged by moving the TBAR.</p>								
<p>WHEEL AUTOENABLE</p>	<p>Press Softkey [JOG] or [SHUTTLE] to enable that function to be engaged by turning the Wheel.</p>								
<p>GANG MODE</p>	<p>Press Softkey to select PERMANENT GANG (described in the FUNCTION TABLE) or TEMPORARY GANG.</p> <p>In TEMPORARY mode, press and hold the VTR key that you want to read status from, then press the VTR#s of those VTRs that you want to include in the gang. Release the keys. The LED on the monitored VTR blinks, all other VTRs in the gang stay on constantly. To break the temporary gang, press any VTR# key.</p>								

ST300 SETUP	<div data-bbox="477 239 954 344" style="border: 1px solid black; padding: 5px; margin-bottom: 10px;"> <p style="text-align: center;">ST300 SETUP</p> <p style="text-align: center;">Clear Cues SetDefault</p> </div> <p>Press Softkey beneath ClearCues to clear all Cue Points to 00:00:00:00. Press Softkey {YES} when asked “Are You Sure?”</p> <p>Press Softkey beneath SetDefault to set ST300 to default settings. Press Softkey {YES} when asked “Are You Sure?”</p>
DISPLAY SOFTWARE VERSION	<p>The version number for the currently installed software is displayed.</p>
VIDEO STANDARD	<p>Press Softkey to select NTSC, PAL, or 24P video standard, depending on the standard you’re using.</p>
INPUT VIDEO DELAY	<p>Input Video Delay specifies the time interval between video recorded on the Recorder part of the DSR being available for playback. This parameter is used in GO TO LIVE function. The default value is 5 seconds.</p>
REFERENCE VIDEO	<p>Press softkey to Enable/Disable Reference Video.</p>
MARK-Q	<p>Press Softkey to: Enable ADVANCE to next Cue Point, when [MARK] is pressed. OR Maintain CURRENT Cue Point when [MARK] is pressed.</p>
DROP FRAME	<p>Press Softkey to select DROP FRAME ON or OFF. Used to preset the VTR’s Timecode Generator.</p>
SEG DURATION	<p>Set for each VTR. Enter SEG duration that will be used to calculate IN (OUT) point.</p>
AUTO MARK	<p>Set for each VTR. Press softkey to turn AUTO MARK ON/OFF. AUTO MARK allows one-key marking of segments.</p>
TRANSMIT CUELIST	<p>Transmits Cuelist to another ST300 or to a PC.</p>
RECEIVE CUELIST	<p>Receives Cuelist from another ST300 or a PC.</p>

8. FUNCTION TABLE

Function	Key Press	Description
EE On/Off	[EE]	Toggle EE mode on/off. Status indicator is on when EE is on.
ENTER TIME	[ENTER TIME]	To manually enter timecode number into the currently displayed Cue Point, enter the desired timecode number using the numeric keypad. Press [ENTER] to save your entry OR [ESC] to exit without saving. To enter a GOTO location without altering the contents of the Cue Point, enter the desired timecode number using the numeric keypad. Press [GOTO] to search to the entered time. Press [ESC] to exit without searching.
DSR START RECORD	[SHIFT] + [RECORD]	Press [SHIFT] + [RECORD] to start recording on selected record channel.
DSR STOP RECORD	[SHIFT] + [STOP]	Press [SHIFT] + [STOP] to stop recording on the selected record channel.
FFWD	[FFWD]	Press and HOLD to FFWD. Release key to stop. Set WIND Speed in MENU.
GOTO CUE	[GOTO]	Search the VTR to the IN Point of the currently displayed Cue Point.
GANG	[SHIFT] + [VTR#1] OR [SHIFT] + [VTR#2] OR [SHIFT] + [VTR#3] OR [SHIFT] + [VTR#4]	Individually press the VTR keys to be included in the gang; the LED above the key will turn on. Press the VTR key again to remove from gang; the LED above the key will turn off. Press [ESC] to exit. The VTR LEDs that are on show the gang. The flashing LED shows which VTR is currently selected.
JOG	[JOG]	Select JOG mode and enable the Wheel.
LAST CUE	[LAST CUE]	Step to the previous Cue Point Location.
MARK CUE POINT	[MARK]	Save the current time in the currently displayed Cue Point. Per SETUP MENU, the Cue Point Location will advance to the next Cue Point location or remain the same.
NEXT CUE	[NEXT CUE]	Step to the next Cue Point Location.
REVERSE PLAY	[REV]	For T-BAR ONLY – HOLD key to play video in reverse. RELEASE key to play forward.
REWIND	[RWD]	Press and HOLD to rewind. Release key to stop. Set WIND Speed in MENU.
SHUTTLE	[SHUTTLE]	Select SHUTTLE mode and enable the Wheel.

SLOMO	[SLOMO]	Press SLOMO to slo-mo the VTR. Turn the Wheel or move the T-Bar to change the play speed. Press SLOMO to STILL frame OR press any transport key to exit.
SLO-MO SPEED PRESET	[SHIFT] + [SLOMO]	For WHEEL ONLY - to preset the slo-mo speed. Turn the Wheel to select desired speed. Press [ESC] OR any transport key to exit.
STOP	[STOP]	Press once to STILL frame VTR. Press again to put VTR into STOP mode.
TIME MODE SELECT	[TIME MODE]	Press to toggle between Timecode (TC), VITC (VT) or Tape Timer (TM) display modes.
GO TO IN POINT	[RECUE]	Press to search to currently set IN point.
MARK IN POINT	[IN]	Save current time as IN point. Per SETUP MENU, the Cue Point Location will advance to the next Cue Point location or remain the same.
MARK OUT POINT	[OUT]	Save current time as OUT point. Note: OUT point is always saved in the current Cue Point.
TIME PRESET (Generator Preset)	[SHIFT] + [TIME MODE]	Press to enter Time Preset. Press [ENTER] to load Time Generator with 00:00:00:00. OR enter the time desired via the numeric keypad and press [ENTER] to load that time. OR press [ESC] to exit without saving.

9. SPECIFICATIONS

Power:	90 VAC to 265 VAC adapter supplied with IEC connector
Size:	(L" x W" x H") 12" x 6" x 1.5" (front) 3.0" (rear) (T-Bar unit is 12.6" long)
Weight:	4 lbs.
Rear Panel Connectors:	VTR1, VTR2, VTR3, VTR4 (All DB9F) GPI (DB15F) Power (DB9M) Aux (DB9F) Reference Video (BNC)
Display:	Easy to read 4-line, back-lit LCD display (User adjustable contrast)
Jog/Shuttle Wheel:	With mechanical detents
Optional "T"-bar:	Slo-mo 0-200% of Play Speed

RS422 SERIAL CONNECTOR

9-Pin D-Type, Female (DB9F)

Pin #	1	Frame Ground	6	Receive Common
	2	Receive A ←	7	Receive B ←
	3	Transmit B →	8	Transmit A →
	4	Transmit Common	9	Frame Ground
	5	Spare		

POWER CONNECTOR

9-Pin D-Type, Male (DB9M)

Pin #	1	+5v DC	6	+5 VDC
	2	+5v DC	7	Ground
	3	Ground	8	Ground
	4	+12 VDC	9	Ground
	5	-12 VDC		

AUX PORT RS422 SERIAL CONNECTOR

9-Pin D-Type, Female

Pin #	1	Frame Ground	6	Transmit Common
	2	Receive A ←	7	Receive B ←
	3	Transmit B →	8	Transmit A →
	4	Receive Common	9	Frame Ground
	5	Spare		

GPI IN/OUT CONNECTOR
15-Pin D-Type, Female (DB15F)

Pin #	Description	Function	Pin #	Description	Function
1	GPI 1 Out	PLAY tally out	9	GPI 1 In	PLAY
2	GPI 2 Out	STILL/STOP tally out	10	GPI 2 In	STOP
3	GPI 3 Out	RECORD tally out	11	GPI 3 In	RECUE
4	GPI 4 Out	REWIND tally out	12	GPI 4 In	NEXT CUE
5	GPI 5 Out	FFWD tally out	13	GPI 5 In	LAST CUE
6	GPI 6 Out	SLOMO tally out	14	GPI 6 In	
7	GPI 7 Out		15	GPI 7 In	
8	Ground				

10. KEY LAYOUT

ST300 KEY CONFIGURATION ST304-DSR1K (& -T)

NOTE- The "REV" key is only available on T-BAR(-T) models

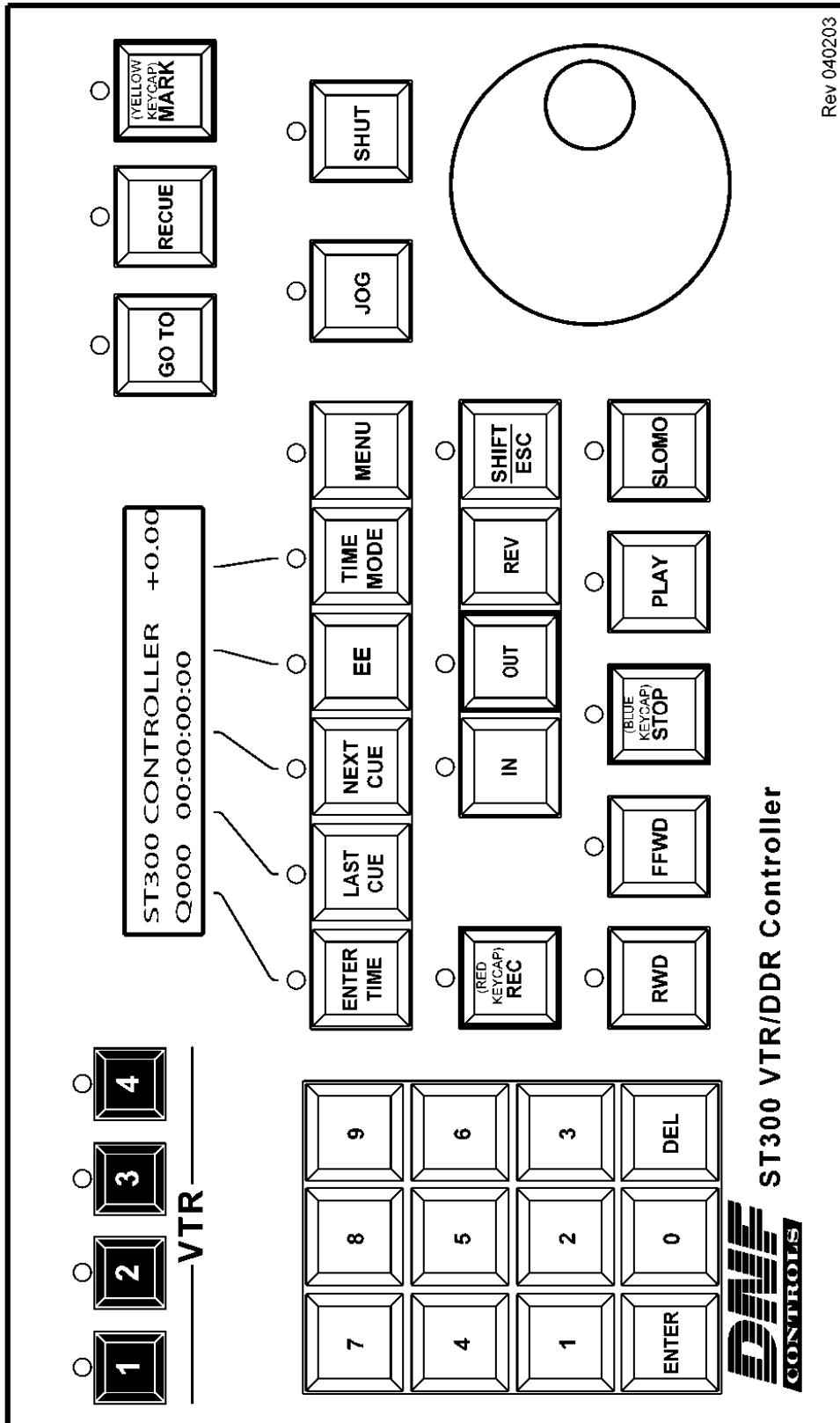

Rev 040203

11. DNF CONTROLS LIMITED WARRANTY

DNF Controls warrants its product to be free from defects in material and workmanship for a period of one (1) year from the date of sale to the original purchaser from DNF Controls.

In order to enforce the rights under this warranty, the customer must first contact DNF's Customer Support Department to afford the opportunity of identifying and fixing the problem without sending the unit in for repair. If DNF's Customer Support Department cannot fix the problem, the customer will be issued a Returned Merchandise Authorization number (RMA). The customer will then ship the defective product prepaid to DNF Controls with the RMA number clearly indicated on the customer's shipping document. The merchandise is to be shipped to:

DNF Controls
12843 Foothill Blvd., Suite C
Sylmar, CA 91342
USA

Failure to obtain a proper RMA number prior to returning the product may result in the return not being accepted, or in a charge for the required repair.

DNF Controls, at its option, will repair or replace the defective unit. DNF Controls will return the unit prepaid to the customer. The method of shipment is at the discretion of DNF Controls, principally UPS Ground for shipments within the United States of America. Shipments to international customers will be sent via air. Should a customer require the product to be returned in a more expeditious manner, the return shipment will be billed to their freight account.

This warranty will be considered null and void if accident, misuse, abuse, improper line voltage, fire, water, lightning or other acts of God damaged the product. All repair parts are to be supplied by DNF Controls, either directly or through its authorized dealer network. Similarly, any repair work not performed by either DNF Controls or its authorized dealer may void the warranty.

After the warranty period has expired, DNF Controls offers repair services at prices listed in the DNF Controls Price List. DNF Controls reserves the right to refuse repair of any unit outside the warranty period that is deemed non-repairable.

DNF Controls shall not be liable for direct, indirect, incidental, consequential or other types of damage resulting from the use of the product.

###